

COUNCIL MEETING AGENDA

Casper City Council
City Hall, Council Chambers
Tuesday, May 2, 2023 at 6:00 p.m.



COUNCIL POLICY PUBLIC STATEMENTS

- I. Members of the Public Wishing to Speak to an Item Already on the Agenda, Other Than a Public Hearing, or Second or Third Reading Ordinance, Must Submit a Request to the City Clerk's Office by 12:00 Noon on the Monday Immediately Preceding the Council Meeting, or May Speak During the Communications from Persons Present.
- II. When Speaking to the City Council Please:
 - Clearly State Your Name
 - Direct all questions/comments to the Mayor and only the Mayor.
 - No personal attacks on staff or Council.
 - Speak to the City Council with Civility and Decorum
- III. The City Council Will Not Respond to Any Comments or Questions Concerning Personnel Matters. Any Such Comments or Questions Will be Handled by the Appropriate Persons. Public Hearing Comments and Presentations Will be Limited to Five Minutes or Less per Person, nor Will Time Extensions be Permitted. No Duplication of Speakers will be Allowed.
- IV. Questions Posed by Speakers May, or May Not be Responded to by Councilors.
- V. Willful Disruption of, or the Breach of the Peace at, a Council Meeting may Result in the Removal of any Such Individuals or Groups from the Council Chambers.
(These Guidelines Are Also Posted at the Podium in the Council Chambers)

Please silence cell phones during the City Council meeting.

Entrance to the meetings is the east door off David Street. Public input via email is encouraged: CouncilComments@casperwy.gov

AGENDA

1. ROLL CALL
2. PLEDGE OF ALLEGIANCE
3. APPROVAL OF COUNCIL MEETING MINUTES

- A. Consideration of **Minutes of the April 4, 2023 Regular Council Meeting**, as Published in the Casper Star-Tribune on April 29, 2023.

We are CASPER

Communication Accountability Stewardship Professionalism Efficiency Responsiveness

B. Consideration of **Minutes of the April 4, 2023 Executive Session.**

C. Consideration of **Minutes of the April 18, 2023 Regular Council Meeting**, as Published in the Casper Star-Tribune on April 30, 2023.

D. Consideration of **Minutes of the April 18, 2023 Executive Session.**

4. CONSIDERATION OF BILLS AND CLAIMS

5. BRIGHT SPOT: TENNIS MONTH

6. COMMUNICATIONS

A. From Persons Present

7. ESTABLISH PUBLIC HEARINGS

A. Consent

1. Establish May 16, 2023 as the Public Hearing Date for Consideration of:

- a. New **Winery Liquor License No. 1 for Gruner Brothers Brewing**, d/b/a Gruner Brothers Brewing, Located at 1301 Wilkins Circle.
- b. **Transfer of Ownership for Retail Liquor License No. 1** from Tin Shack, LLC d/b/a **Poplar Wines & Spirits**, Located at 1016 South Poplar Street to 1016 Poplar, LLC d/b/a **Poplar Wines & Spirits**, Located at 1016 Poplar, LLC.
- c. New **Restaurant Liquor Licenses No. 51** for Movie Palace Inc., d/b/a **Studio City Stadium 10 Cinemas**, Located at 5020 East 2nd Street.

8. PUBLIC HEARINGS

A. Minute Action

- 1. **Transfer of Ownership for Retail Liquor License No. 37** from Charger Holdings, LLC d/b/a Charger Holdings, LLC, Located at 355 West Yellowstone to Bull Horn Brewing, LLC d/b/a **Bull Horn Brewing**, Located at 355 West Yellowstone Hwy.

9. SECOND READING ORDINANCE

A. Creating City of Casper, Wyoming **Local Assessment District No. 159** (Hereinafter Called the “District”); Ordering the Construction of Improvements Therein; Describing the Same, Directing the Preparation of Plans and Specifications Therefor; Providing for the Publication of Notice to Contractors; Fixing the Boundaries of Said District; Ratifying Action Previously Taken; and, Prescribing Details in Connection with Said District.

1. Communications from Persons Present

We are CASPER

Communication Accountability Stewardship Professionalism Efficiency Responsiveness

B. Approving a Zone Change of Lot 1, **Majestic Mountain Addition**, from PH (Park Historic) to C-2 (General Business).

1. Communications from Persons Present

C. Approving the **Highland Park Tennis Complex Addition**, and the Associated Subdivision Agreement.

1. Communications from Persons Present

D. Approving a Plat, Subdivision Agreement, and Zone Change for the **Lukasiewicz Subdivision** in the City of Casper, Wyoming.

1. Communications from Persons Present

10. THIRD READING ORDINANCE

A. Approving **Amendments to the Liquor License Code Sections**, 5.08.150 and 5.08.390.

1. Communications from Persons Present

11. RESOLUTIONS

A. Consent

1. Authorizing Amendment No. 1 to the Contract for Professional Services Between the City of Casper and HDR Engineering.

2. Authorizing a Contract for Professional Services with **Forterra Concrete Products, Inc.**, for **Manufacturing Concrete Blocks** to be Used at the Casper Compost Yard, Project No. 22-050.

3. Authorizing an Agreement with LER, Inc., DBA **Renner Sports Surfaces**, for the **Highland Park Pickleball Court Resurfacing**, Project No. 23-013.

4. Authorizing an Agreement with **Caspar Building Systems, Inc.**, for the **City Hall Project S.A.F.E. Building Remodel**, Project No. 20-004.

5. Authorizing Amendment No. 1 to the Contract for Professional Services with **WLC Engineering & Surveying**, for Construction Administration Services for the **Industrial Avenue Drainage & Surfacing Improvements (Elm to David)**, Project No. 21-055.

6. Authorizing an Agreement Between the City of Casper and the **Natrona County Conservation District**.

7. Authorizing a **Transportation Services Contract** for Transit Services for the **Town of Evansville**, a Wyoming Municipality, for Fiscal Year 2023.

We are **CASPER**

Communication Accountability Stewardship Professionalism Efficiency Responsiveness

8. Authorizing a **Telephone Line Easement Agreement** Between the City of Casper, Wyoming and **Natrona County**, Wyoming.
9. Authorizing Submission of an Application to the **WaterSMART Aquatic Ecosystem Restoration Projects Grant** Program.
10. Authorizing Acceptance of a **Child Stabilization Grant** from the **Wyoming Department of Family Services** in the Amount of One Hundred Fifty-Six Thousand Five Hundred Dollars.
11. Authorizing **Amendment Two to the Grant Award Agreement** Between the **Wyoming Office of Homeland Security** and City of Casper. (Regional Response Grant #20)
12. Authorizing **Amendment Two to the Grant Award Agreement** Between the **Wyoming Office of Homeland Security** and City of Casper. (Regional Response Grant #21)
13. Authorizing the **Grant Award Agreement** Between the **Wyoming Office of Homeland Security** and City of Casper.

12. MINUTE ACTION

A. Consent

1. **Rejecting All Bids** Received for the 2023 5-Year **Solid Waste Baler Bag Procurement**, Project No. 23-006.
2. **Appointing One (1) New Member** to **Casper's Council of People with Disabilities** for a Term of Three (3) Years Beginning May 2, 2023.

13. INTRODUCTION OF MEASURES AND PROPOSALS BY MEMBERS OF THE CITY COUNCIL

14. ADJOURN INTO EXECUTIVE SESSION –PERSONNEL

15. ADJOURNMENT OF REGULAR MEETING

Upcoming Council Meetings

Regular Council Meetings

6:00 p.m. Tuesday, May 16, 2023 – Council Chambers

6:00 p.m. Tuesday, June 6, 2023 – Council Chambers

Work Sessions

4:30 p.m. Tuesday, May 9, 2023– Council Meeting Room

4:30 p.m. Tuesday, May 23, 2023 – Council Meeting Room

We are CASPER

Communication Accountability Stewardship Professionalism Efficiency Responsiveness

ZONING CLASSIFICATIONS

FC	Major Flood Channels & Riverbanks	PUD	Planned Unit Development
AG	Urban Agriculture	HM	Hospital Medical
R-1	Residential Estate	C-1	Neighborhood Convenience
R-2	One Unit Residential	C-2	General Business
R-3	One to Four Unit Residential	C-3	Central Business
R-4	High-Density Residential	C-4	Highway Business
R-5	Mixed Residential	M-1	Limited Industrial
R-6	Manufactured Home (Mobile) Park	M-2	General Industrial
PH	Park Historic	SMO	Soil Management Overlay

We are **CASPER**

Communication Accountability Stewardship Professionalism Efficiency Responsiveness

COUNCIL PROCEEDINGS
Casper City Hall – Council Chambers
April 4, 2023

1. ROLL CALL

Casper City Council met in regular session at 6:04 p.m., Tuesday, April 4, 2023. Present: Councilors Jensen, Cathey and Mayor Knell. Councilors Bond, Haskins, Gamroth, Pollock, Engebretsen, and Vice Mayor Pacheco attended the meeting virtually.

2. PLEDGE OF ALLEGIANCE

Mayor Knell led the audience in the pledge of allegiance.

3.A. REGULAR MEETING MINUTES

Moved by Councilor Engebretsen, seconded by Councilor Jensen to, by minute action, approve the minutes of the March 7, 2023 Regular Council Meeting, as published in the Casper Star Tribune on March 26, 2023. Motion passed.

3.B. EXECUTIVE SESSION MINUTES

Moved by Vice Mayor Pacheco, seconded by Councilor Gamroth to, by minute action, approve the minutes of the March 7, 2023 Executive Session. Motion passed.

3.C. REGULAR MEETING MINUTES

Moved by Councilor Cathey, seconded by Councilor Jensen to, by minute action, approve the minutes of the March 21, 2023 Regular Council Meeting, as published in the Casper Star Tribune on March 29, 2023. Motion passed.

3.D. EXECUTIVE SESSION MINUTES

Council inadvertently skipped this item to consider approval of the minutes of March 21, 2023 Executive Session. This item will be added to the next regular Council meeting for approval.

4. BILLS & CLAIMS

Moved by Councilor Pollock seconded by Councilor Engebretsen to, by minute action, approve payment of the April 4, 2023, bills and claims, as audited by City Manager Napier. Motion passed.

Bills & Claims 04/04/23

6HGroup	Goods	115.60
71Constr	Goods	3,120.00
ActnGlss	Services	1,250.00
AirInnvtns	Services	1,080.00
Airgas	Goods	3,605.02
All-OutFire	Goods	1,170.00
Alsco	Services	1,475.11
AltdVtrnry	Services	367.10
Amrgs	Goods	4,044.58
AMBI	Services	1,653.59
AppldCnpts	Goods	2,372.50

Ardurra	Services	6,989.12
Arrwhd	Services	359.75
AT&T	Services	1,005.76
Atlas	Goods	10,321.80
BlkHillsEnrgy	Utilities	76,709.33
BlkmnPrpn	Goods	1,872.08
BoysGirls	Services	14,372.75
BWorley	Reimb	150.00
CptlBusnsSystem	Services	61.80
CrlnaSftwr	Goods	510.00
Caselle	Services	156.00
CsprStrTrb	Services	820.40
CsprTinShop	Services	270.00
CsprTire	Services	210.00
CntrlTrk&Dsl	Services	5,610.97
CntryLnk	Utilities	13,691.87
CSimons	Reimb	338.00
CtyCspr	Services	203,645.27
CtyEvnstn	Services	49.95
CivicPlus	Goods	639.32
CMITeco	Services	45,694.24
CoastlChmcl	Goods	186.35
CocaCola	Services	16.50
CommTech	Services	83,506.00
CntnrCpmnts	Goods	6,447.54
Cnvrn	Goods	31,619.04
CoreMain	Goods	47,779.00
CPU	Goods	39,798.00
CrtAppntSpcl	Services	777.80
CwbySpplHse	Goods	421.46
Creed	Services	2,125.00
CrimeScnInfo	Services	122.00
CrwnCnstrctn	Services	41,306.00
DKpnr	Services	3,151.50
DckrAuto	Services	518.74
Dell	Goods	67,611.99
DKaiser	Reimb	150.00

DMarquez	Reimb	100.00
DsrtMtn	Goods	6,899.20
DooleyEnt	Goods	31,436.47
DPCIndstrs	Goods	13,077.47
EatonSls&Svc	Services	635.00
EnrgyLabs	Services	1,400.00
ExpSvcs	Services	2,185.68
FlsbrgHolt&Ullevig	Services	4,602.56
FrgsnEnt	Goods	6,700.65
FIB	Goods/Invstmnts	722.00
Galloway & Company in	Services	13,375.00
Galls	Goods	1,429.78
Grngr	Goods	2,225.77
Hach	Goods	355.40
HrvrdDrgG	Goods	208.71
HDREngnrng	Services	40,133.03
HLockhart	Reimb	59.64
HitekCmm	Services	1,044.00
Homax	Goods	102,750.33
HometownMfc	Goods	196,826.00
Hose&RubrSply	Goods	143.36
HydroOptmztn	Services	3,388.50
IecUS	Services	10,865.00
ITCElctrel	Services	2,390.40
JWatson	Reimb	250.00
JacobsEngnrng	Services	21,074.85
JonasSftwr	Services	349.00
KarcherNA	Goods	6,154.79
Kinsco	Goods	10,789.91
KPatrick	Reimb	3,000.00
KLJSltns	Services	10,862.35
KnfRvr	Services	237.28
LIselin	Reimb	500.00
LNCrts&Sons	Goods	12,980.00
MercerHse	Services	8,001.32
MonsnIntrlSrv	Services	6,963.40
MotherSeton	Services	9,076.38

Motn&FlowCntrl	Goods	2,290.33
MillsPD	Services	84.00
MtnAlrmFire&Scrty	Services	4,273.50
MtnStLitho	Services	663.77
MtnStPipe	Goods	10,049.63
MtnWstTech	Services	1,000.00
MuniEmrgncySrvc	Goods	2,940.00
Nkaiser	Reimb	3,000.00
NCPL	Services	46,105.00
NCSO	Services	84.00
Norco	Goods	1,126.56
NrthwstCntrctrs	Goods	959.32
NVACsprVet	Services	1,071.73
PaceAnlytclSrvc	Services	217.20
PCNStrtgs	Goods	335.70
Pedens	Goods	110.00
Pipelogix	Goods	2,000.00
PSantistevan	Reimb	31.49
PlmbngMstrs	Refund	351.00
PstlPros	Services	8,820.41
PwrPh	Services	1,458.00
RapidFirePrctctn	Services	6,925.00
RTasler	Reimb	150.00
RMcMillen	Reimb	100.00
RgnVIIIPrtr	Services	300.00
Rexel	Services	2,727.36
Ricoh	Services	10,700.00
RisslerPlmb	Services	2,880.61
RckyMtnAirSltns	Goods	167.16
RckyMtnAccred	Services	225.00
RckyMtnPwr	Utilities	148,587.12
RootrSwr	Services	1,639.30
Saltus Tech	Services	1,131.00
Serpentix Conveyor	Services	86,982.70
Shrts&More	Goods	500.00
SixRbbls	Goods	670.02
SmthPsych	Services	900.00

StOfWyo	Services	56,370.59
StellrPrgrmng	Services	1,993.75
SummitElctrc	Services	1,360.60
SummitFire&Scrty	Services	374.50
SunCntry	Goods	8,757.76
SJensen	Reimb	210.79
TrgtSpelty	Goods	1,455.48
Thtchr	Goods	18,298.00
TimFrc	Services	243.00
TriStOil	Services	577.50
TWEntrprs	Services	362.00
TylerTech	Services	1,062.80
Unifrms2Gear	Goods	431.80
UntdWy	Services	946.94
VrznWrsls	Services	604.10
VDiaz	Reimb	150.00
WstrnRes	Services	3,894.23
WstrnSign&Design	Services	130.70
WWCEngnrng	Services	18,338.25
WstlndPrk	Services	1,758.79
WLCEngnrng	Services	658.00
WyoMchnry	Services	6,893.56
Wyo1stAid	Goods	78.76
Total		1,738,970.87

4. COMMUNICATIONS FROM PERSONS PRESENT

Individuals addressing Council were: Will Gay, regarding the Westridge LAD. Council discussed the notification and neighborhood meeting process for the LAD. Council directed staff to hold another neighborhood meeting before the public hearing for this item with head engineers present.

5.A.1. ESTABLISH DATE OF PUBLIC HEARINGS

Moved by Councilor Cathey seconded by Councilor Jensen, to, by minute action, establish April 18, 2023, as the public hearing date for consideration of:

- a. A Resolution Authorizing a Real Estate Purchase Agreement Between Natrona County, Wyoming and the City of Casper, Wyoming Regarding the City's Sale of 8 Acres, More or Less, of Property Located at the Northeast Corner of East 12th Street and Conwell Street.
- b. An Ordinance to Create Local Assessment District 159 – Westridge Improvements.
- c. An Ordinance Approving a Zone Change of Lot 1, Majestic Mountain Addition, from PH (Park Historic) to C-2 (General Business).
- d. An Ordinance Approving the Highland Park Tennis Complex Addition, and the Associated Subdivision Agreement.

e. An Ordinance Approving a Plat, Subdivision Agreement, and Zone Change for the Lukasiewicz Subdivision in the City of Casper, Wyoming.
Motion passed.

6. PUBLIC HEARING - ORDINANCE

Mayor Knell opened the public hearing for the consideration of an ordinance amending liquor sections in the Casper Municipal Code.

City Attorney Nelson entered two (2) exhibits: correspondence from Fleur Tremel to J. Carter Napier, dated March 27, 2023; and an affidavit of publication, as published in the Casper Star Tribune, dated March 27, 2023. City Manager Napier provided a brief report.

There were no citizens speaking in favor of the ordinance. Speaking in opposition was: Seth Hollier. There being no other citizens to speak for or against the issue, the public hearing was closed.

Following ordinance read:

ORDINANCE NO. 5-23
AN ORDINANCE UPDATING AND AMENDING CHAPTER 5.08 OF
THE CASPER MUNICIPAL CODE, INCLUDING SECTIONS 5.08.150
AND 5.08.390.

Councilor Gamroth presented the foregoing ordinance for approval on first reading. Seconded by Councilor Haskins. Councilors Gamroth and Bond stated that he did not agree with changing the hours to earlier in the morning. Councilor Haskins explained that changing the hours will make the hours consistent across all types of liquor licenses. Mayor Knell stated that this also helps cater to golf course tournaments, clubs (such as VFW), and shift workers. Chief McPheeters stated that changing hours to 6 a.m. should not have a substantial effect on public safety, but changing the hours from 2 a.m. to 4 p.m., as suggested by Mr. Hollier, would have an impact on public safety within the City. Council discussed incentive programs suggested by Mr. Hollier, but stated that should be its own separate discussion and does not necessarily apply to this ordinance. City Clerk/Assistant to the City Manager Fleur Tremel, stated that hours can be changed four times per year for bars, but this would apply to all bars and would not be applied to a just one establishment. Councilor Pollock abstained from voting; Councilors Gamroth and Bond voted nay; and all others voted aye. Motion passed.

7. CONSENT RESOLUTIONS

The following resolutions were considered, by consent agenda:

RESOLUTION NO. 23-49
A RESOLUTION AUTHORIZING AN AGREEMENT WITH SHEET
METAL SPECIALTIES, INC., FOR THE WASTE WATER
COLLECTIONS BUILDING HVAC UPGRADES, PROJECT NO. 22-
039.

RESOLUTION NO. 23-50
A RESOLUTION AUTHORIZING CHANGE ORDER NO. 4 TO THE
AGREEMENT WITH INSITUFORM TECHNOLOGIES, LLC, FOR
THE NORTH PLATTE SANITARY SEWER REHABILITATION,
PROJECT NO. 20-015.

RESOLUTION NO. 23-51

A RESOLUTION AUTHORIZING THE ACCEPTANCE OF THE 2022 BJA EDWARD BYRNE MEMORIAL JUSTICE ASSISTANCE GRANT AND A MEMORANDUM OF UNDERSTANDING BETWEEN THE CITY OF CASPER AND NATRONA COUNTY REGARDING THE DISTRIBUTION AND EXPENDITURE OF THE GRANT FUNDS.

RESOLUTION NO. 23-52

A RESOLUTION AUTHORIZING A CONTRACT FOR PROFESSIONAL SERVICES BETWEEN THE CITY OF CASPER AND MOTOROLA SOLUTIONS, INC. TO CREATE A CITIZEN ENGAGEMENT PORTAL FOR THE CASPER POLICE DEPARTMENT.

RESOLUTION NO. 23-53

A RESOLUTION AUTHORIZING AMENDMENT NO. 1 TO THE CONTRACT FOR PROFESSIONAL SERVICES BETWEEN THE CITY OF CASPER AND FELSBURG, HOLT, & ULLEVIG, INC.

Councilor Engebretsen presented the foregoing five (5) resolutions for adoption. Seconded by Councilor Cathey. Motion passed.

8.A. CONSENT MINUTE ACTION

Moved by Councilor Jensen, seconded by Councilor Haskins, to, by consent minute action:

1. Authorize the Purchase of Two (2) New Two-Ton 4x4 Crew Cab with Dual Rear Wheel Cab and Chassis for Use by the Casper Fire EMS Department;
2. Authorize the Purchase One (1) New Half-Ton 4x4 Super Cab Pickup Truck with 6.5' Bed for Use by the Buildings and Structures Division of the Parks, Recreation, and Public Facilities Department;
3. Authorize the Purchase of One (1) New Front-End Wheel Loader for Use by the Solid Waste Division of the Public Services Department; and,
4. Authorize the Purchase of One (1) New Fourteen-Foot Dump Trailer for Use by the Parks Division of the Parks, Recreation, and Public Facilities Department.

Motion passed.

9. INTRODUCTION OF MEASURES AND PROPOSALS

Councilors spoke on meetings and events they attended as well as matters of public interest. Councilors thanks staff and citizens for their efforts in clearing roads and sidewalks during the snow storm.

10. ADJOURN INTO EXECUTIVE SESSION

At 6:57 p.m., it was moved by Councilor Cathey, seconded by Councilor Jensen, to adjourn into executive session to discuss litigation and personnel. Motion passed.

At 8:08 p.m., there being no further business, Mayor Knell asked for a motion to adjourn the executive session. Moved by Councilor Cathey seconded by Councilor Jensen. Motion Passed.

12. ADJOURNMENT

Council opened the meeting to the public. At 8:08 p.m. Mayor Knell called for a motion to adjourn the regular meeting. Moved by Councilor Cathey, seconded by Councilor Jensen. Motion passed.

ATTEST:

CITY OF CASPER, WYOMING
A Municipal Corporation

Fleur Tremel
City Clerk

Bruce Knell
Mayor

COUNCIL PROCEEDINGS
Casper City Hall – Council Chambers
April 18, 2023

1. ROLL CALL & PLEDGE OF ALLEGIANCE

Casper City Council met in regular session at 6:03 p.m., Tuesday, April 18, 2023. Present: Councilors Pollock, Bond, Haskins, Gamroth, Jensen, Engebretsen, Vice Mayor Pacheco and Mayor Knell. Absent: Councilor Cathey.

Moved by Councilor Pollock, seconded by Vice Mayor Pacheco to, by minute action, excuse the absence of Councilor Cathey. Motion passed.

Vice Mayor Pacheco led the audience in the pledge of allegiance.

2.A. SPECIAL MEETING MINUTES

Moved by Councilor Gamroth, seconded by Councilor Engebretsen to, by minute action, approve the minutes of the March 30, 2023 Special Council Meeting, as published in the Casper Star Tribune on April 7, 2023. Motion passed.

2.B. EXECUTIVE SESSION MINUTES

Moved by Councilor Gamroth, seconded by Councilor Pollock to, by minute action, approve the minutes of the March 21, 2023 Executive Session. Motion passed.

3. BILLS & CLAIMS

Moved by Councilor Engebretsen, seconded by Councilor Gamroth to, by minute action, approve payment of the April 18, 2023, bills and claims, as audited by City Manager Napier. Motion passed.

Bills & Claims 04/18/23

6HGroup	Goods	115.60
71Constr	Goods	1,654.50
AAALndscpng	Services	745.00
AGoodwin	Reimb	300.00
Airgas	Goods	46.20
Alsco	Services	1,659.89
AltdVtrnry	Services	2,500.00
AMBI	Services	332.33
AmrTech	Services	832.33
Arrwhd	Services	287.00
AT&T	Services	18,359.29
AtIntcElctrc	Services	30,500.00
AtlasOffice	Goods	3,351.59
AtlasRepr	Services	51.00
AtlasPrem	Services	30.00
BdgrMtr	Goods	161.98
Bailey's	Goods	13.89

BlkmmPrpn	Goods	4,315.09
BGoebel	Refund	30.60
CrlnaSftwr	Goods	700.00
CsprNC	Services	47,914.33
CsprStrTrb	Services	3,922.54
CsprTire	Services	990.00
CntrlTrk&Dsl	Services	873.72
CWRWS	Goods	346,630.38
CntrlWyoHospice&Trnstns	Services	28,750.54
CntryLnk	Utilities	4,570.11
ChldDvCntr	Services	10,625.00
CtyCspr	Services	532,355.65
CKMchncl	Services	199.00
CleanCl	Services	1,155.00
CMITeco	Services	9,506.55
CommTech	Services	9,365.87
CmprsnLeasng	Services	3,529.22
CnsnsCloudSltns	Services	203.54
CHughes	Reimb	395.38
Cnvrngn	Goods	25,347.29
CoreMain	Goods	1,272.50
CSchneider	Refund	38.83
DckrAuto	Services	716.87
DJarrell	Reimb	794.88
DCourtade	Reimb	150.00
DecksUnlmtd	Refund	84.73
DsrtMtn	Goods	34,518.02
DooleyOil	Goods	4,933.77
DPCIndstrs	Goods	12,576.44
EmrgncyMdcl	Services	800.00
EBecher	Reimb	240.50
EChristensen	Reimb	200.00
EnrgyLabs	Services	1,914.00
EnrgyMngmnt	Services	513.61
ExpSvcs	Services	1,328.59
FlydTrckCntr	Services	4,595.15
FrgsnEnt	Goods	8,195.00

FIB	Goods/Invstmnts	218.00
FoxstrOpco	Goods	1,110.00
FrmntMtr	Goods	84,406.00
Galls	Goods	158.40
GrtrWyoBB/BS	Services	4,476.38
Greens	Services	165.00
GrngrMotr	Goods	835.78
GSGArchctr	Services	72,285.50
HrdlnEquip	Services	10,084.62
HrvrdDrgG	Goods	328.92
HDREngnrng	Services	3,885.75
Homax	Goods	7,138.15
HrznCble	Services	928.34
IME	Services	1,848.30
JGreenwood	Reimb	147.03
JacksTrk&Trlr	Services	2,269.49
JJTrailer	Goods	6,868.74
Keenan	Goods	987.76
Kinsco	Goods	650.00
KnfRvr	Services	683.69
KubwtrRsc	Goods	8,300.00
LNCrts&Sons	Goods	1,954.14
LawsonPrdcts	Services	900.00
Lisa'sSpnSpn	Services	455.00
LongBldgTech	Services	15,955.78
MDMdclRsrs	Goods	48,381.00
MIgrdCnstrctn	Services	24,187.00
MKolker	Reimb	188.49
MLAuto	Services	377.00
MoMonTai	Goods	145.00
MdrnElctrc	Services	34,722.50
MonsnJntrlSrvc	Services	225.00
Motn&FlowCntrl	Goods	1,012.20
MotorlaSltns	Services	18,915.34
MtnAlrmFire&Scrty	Services	2,043.10
MtnWstTech	Services	599.32
NIRA	Services	22,000.00

NCSO	Services	171,091.08
NCHallOfJstc	Services	19,451.32
Norco	Goods	1,044.31
NWstLinings&Geotxtl	Services	147,301.54
NVACsprVet	Services	86.86
OffcShop	Services	70.35
OneCall	Services	907.50
PeakGeosltns	Services	9,576.15
Pedens	Goods	451.00
PstlPros	Services	19,281.98
ProPaintWY	Services	575.00
PrfsnlCIng	Services	1,395.00
PblcSftyTstng	Services	3,640.00
RngSrvntAmrc	Goods	14,415.00
RapidFirePrtctn	Services	795.00
Ricoh	Services	472.43
RckyMtnPwr	Utilities	43,194.93
RootrSwr	Services	506.65
Safariland	Goods	872.40
SheetMetlSpec	Services	180.00
SimplotTurf	Goods	3,679.90
SkylnRnchs	Services	84.78
Smrsh	Services	2,048.30
StOfWyo	Services	9,373.30
StrIngInfosystms	Services	1,707.38
SummitElctrc	Services	440.00
SummitFire&Scrty	Services	697.94
TrgtSpclty	Goods	8,718.72
TheRdrShp	Services	8,263.70
TRoylance	Reimb	124.99
TopOffc	Goods	328.48
Uline	Services	9,952.34
Unifrms2Gear	Goods	236.28
VrznWrsl	Services	2,130.62
VRC	Services	92.61
WyneColemnConst	Services	9,825.00
WstPlainsEngnrng	Services	1,500.00

WstrnStLrn	Services	2,650.00
WWCEngnrng	Services	24,135.35
WstlndPrk	Services	1,802.89
WH	Services	912.50
WSP	Services	14,618.40
WYLEChplns	Services	400.00
WYFireChfs	Services	160.00
WyoMchnry	Services	9,118.59
Wyo1stAid	Goods	121.48
WyoSteel&Rcycling	Goods	382.60
Total		2,093,844.67

4. BRIGHT SPOT

Mayor Knell introduced members of the Donor Alliance Group, including Jennifer Prinz, President and CEO; Gary Loughry, Regional Donation Consultant; Jessie Caputa, Community Relations Coordinator; and Jason Wynia, Misty Wynia, Anne Bina, and Bob Bina, Advocates for Life. The attending members and advocates introduced themselves and told their stories of involvement with the Donor Alliance Group. Mayor Knell then proclaimed April as National Donate Life Month for the City of Casper and read and presented the proclamation to the staff and advocates in attendance.

5. COMMUNICATIONS FROM PERSONS PRESENT

Individuals addressing Council were: Woody Giles, regarding ways to combat homelessness in the community.

6. ESTABLISH DATE OF PUBLIC HEARINGS

Moved by Councilor Engebretsen seconded by Councilor Gamroth, to, by minute action, establish May 2, 2023, as the public hearing date for consideration of a transfer of ownership for Retail Liquor License No. 37 from Charger Holdings, LLC, dba Charger Holding LLC, located at 355 W. Yellowstone, to Bull Horn Brewing, LLC, dba Bull Horn Brewing, located at 355 West Yellowstone Hwy.

Councilor Pollock abstained from voting. Motion passed.

7.A.1. PUBLIC HEARING - ORDINANCE

Mayor Knell opened the public hearing for the consideration of an ordinance regarding Local Assessment District No. 159 – Westridge Improvements.

City Attorney Nelson entered four (4) exhibits: correspondence from Andrew Beamer to J. Carter Napier, dated April 5, 2023; an affidavit of publication, as published in the Casper Star Tribune, dated March 23, 2023; correspondence from property owners, received between March 23 and March 29, 2023; and an ownership and assessment roll, dated February 2, 2023. City Manager Napier provided a brief report.

Speaking in support was: Cindy Blazek. There were no citizens speaking in opposition of the ordinance. There being no other citizens to speak for or against the issue, the public hearing was

closed.

Following ordinance read:

ORDINANCE NO. 6-23

AN ORDINANCE CREATING CITY OF CASPER, WYOMING, LOCAL ASSESSMENT DISTRICT NO. 159 (HEREINAFTER CALLED THE "DISTRICT"); ORDERING CONSTRUCTION OF IMPROVEMENTS THEREIN; DESCRIBING THE SAME, DIRECTING THE PREPARATION OF PLANS AND SPECIFICATIONS THEREFOR; PROVIDING FOR THE PUBLICATION OF NOTICE TO CONTRACTORS; FIXING THE BOUNDARIES OF SAID DISTRICT; RATIFYING ACTION PREVIOUSLY TAKEN; AND, PRESCRIBING DETAILS IN CONNECTION WITH SAID DISTRICT.

Vice Mayor Pacheco presented the foregoing ordinance for approval on first reading. Seconded by Councilor Jensen. Mayor Knell stated that the City had overwhelming support from the neighbors who attended the second neighborhood meeting. Public Services Director, Andrew Beamer, discussed the ways that property owners have been notified of the LAD and asked for their input. Councilor Pollock and Vice Mayor Pacheco suggested additional communications so that all property owners continue to be aware of the LAD and are provided all necessary information. Motion passed.

7.A.2. PUBLIC HEARING - ORDINANCE

Mayor Knell opened the public hearing for the consideration of an ordinance regarding a zone change in the Majestic Mountain Addition.

City Attorney Nelson entered two (2) exhibits: correspondence from Liz Becher to J. Carter Napier, dated April 14, 2023; and an affidavit of publication, as published in the Casper Star Tribune, dated April 10, 2023. City Manager Napier provided a brief report.

There were no citizens to speak for or against the issue; the public hearing was closed.

Following ordinance read:

ORDINANCE NO. 7-23

AN ORDINANCE APPROVING A ZONE CHANGE OF LOT 1, MAJESTIC MOUNTAIN ADDITION, FROM PH (PARK HISTORIC) TO C-2 (GENERAL BUSINESS).

Councilor Bond presented the foregoing ordinance for approval on first reading. Seconded by Councilor Gamroth. Councilor Pollock asked why C-2 zoning was chosen as opposed to a residential zoning. City Planner, Craig Collins, responded that the land is near other C-2 zoning. Councilor Engebretsen abstained from voting. Motion passed.

7.A.3. PUBLIC HEARING - ORDINANCE

Mayor Knell opened the public hearing for the consideration of an ordinance regarding a plat and subdivision agreement for the Highland Park Tennis Complex Addition.

City Attorney Nelson entered two (2) exhibits: correspondence from Liz Becher to J. Carter Napier, dated April 14, 2023; and an affidavit of publication, as published in the Casper Star Tribune, dated April 10, 2023. City Manager Napier provided a brief report.

Speaking in favor of the ordinance was: Shawn Lutz. He expressed concerns about the height of the fence surrounding the courts, and City Manager Napier stated he will pass that information to the school district. There were no citizens to speak in opposition of the ordinance. There being no other citizens to speak for or against the issue; the public hearing was closed.

Following ordinance read:

ORDINANCE NO. 8-23
AN ORDINANCE APPROVING THE HIGHLAND PARK TENNIS
COMPLEX ADDITION, AND THE ASSOCIATED SUBDIVISION
AGREEMENT.

Councilor Pollock presented the foregoing ordinance for approval on first reading. Seconded by Councilor Engebretsen. Motion passed.

7.A.4. PUBLIC HEARING - ORDINANCE

Mayor Knell opened the public hearing for an ordinance regarding a plat, subdivision agreement, and zone change for the Lukasiewicz Subdivision.

City Attorney Nelson entered two (2) exhibits: correspondence from Liz Becher to J. Carter Napier, dated April 14, 2023; and an affidavit of publication, as published in the Casper Star Tribune, dated April 10, 2023. City Manager Napier provided a brief report.

Speaking in support of the ordinance was: Shawn Gustafson. There were no citizens speaking in opposition. There being no other citizens to speak for or against the issue; the public hearing was closed.

Following ordinance read:

ORDINANCE NO. 9-23
AN ORDINANCE APPROVING A PLAT, SUBDIVISION
AGREEMENT AND ZONE CHANGE FOR THE LUKASIEWICZ
SUBDIVISION IN THE CITY OF CASPER WYOMING.

Councilor Bond presented the foregoing ordinance for approval on first reading. Seconded by Councilor Jensen. Councilor Engebretsen abstained from voting. Motion passed.

7.B. PUBLIC HEARING - RESOLUTION

Mayor Knell opened the public hearing for the consideration of a resolution authorizing a real estate purchase agreement with Natrona County regarding the City's sale of property located at the corner of 12th Street and Conwell Street.

City Attorney Nelson entered two (2) exhibits: correspondence from Wallace Trembath to J. Carter Napier, dated April 6, 2023; and an affidavit of publication, as published in the Casper Star Tribune, dated March 27, 2023. City Manager Napier provided a brief report.

Speaking in support of the ordinance was: Peter Nicolaysen, Natrona County Commissioner. There

were no citizens speaking in opposition. There being no other citizens to speak for or against the issue; the public hearing was closed.

Following resolution read:

RESOLUTION NO. 23-54
A RESOLUTION AUTHORIZING A REAL ESTATE PURCHASE AGREEMENT BETWEEN NATRONA COUNTY, WYOMING AND THE CITY OF CASPER, WYOMING REGARDING THE CITY'S SALE OF 8 ACRES, MORE OR LESS, OF PROPERTY LOCATED AT THE NORTHEAST CORNER OF EAST 12TH STREET AND CONWELL STREET.

Vice Mayor Pacheco presented the foregoing ordinance for approval on first reading. Seconded by Councilor Haskins. Mayor Knell explained that this land will be used by the County for a public health facility. Motion passed.

8. ORDINANCE— SECOND READING

Following ordinance read:

ORDINANCE NO. 5-23
AN ORDINANCE UPDATING AND AMENDING CHAPTER 5.08 OF THE CASPER MUNICIPAL CODE, INCLUDING SECTIONS 5.08.150 AND 5.08.390.

Councilor Gamroth presented the foregoing ordinance for adoption, on second reading. Seconded by Councilor Jensen.

Citizens to speak about the ordinance were: Seth Hollier, explaining that he did not support the changes for earlier serving times for certain liquor establishments.

Mayor Knell asked for discussion on the ordinance. Councilor Engebretsen stated that she would vote against the ordinance due to the earlier serving times outlined in the ordinance. Councilor Gamroth also stated that he would vote against the ordinance because he is not in favor of the liberalization of liquor laws. Councilors Jensen and Bond, and Vice Mayor Pacheco, and Mayor Knell, stated that they supported the ordinance because it aligns all of the serving hours for every type of liquor establishment in Casper. City Attorney Nelson explained that the original revisions to the ordinance in 2017 did not include these two extra types of establishments due to an oversight. Vice Mayor Pacheco and Mayor Knell stated that if Council would like to look into changing hours to later in the morning/afternoon for all liquor establishments, they should discuss this at a work session but should not punish these two types of establishments due to an oversight. There were no amendments. Councilor Pollock abstained from voting. Councilors Gamroth and Engebretsen voted no. Motion passed.

9. CONSENT RESOLUTIONS

The following resolutions were considered, by consent agenda:

RESOLUTION NO. 23-55
A RESOLUTION APPROVING A SITE PLAN AND ACCEPTING THE GROUND LEASE AGREEMENT BETWEEN THE CITY AND WYO COMPLEX AS THE SITE PLAN AGREEMENT.

RESOLUTION NO. 23-56

A RESOLUTION AUTHORIZING AMENDMENT NO. 1 TO THE CONTRACT FOR PROFESSIONAL SERVICES BETWEEN THE CITY OF CASPER AND HDR ENGINEERING, INC.

RESOLUTION NO. 23-57

A RESOLUTION AUTHORIZING A CONTRACT BETWEEN THE CITY OF CASPER AND CIVIL ENGINEERING PROFESSIONALS, INC., FOR THE MILLS PLATTE RIVER TRAIL CONNECTIVITY STUDY.

RESOLUTION NO. 23-58

A RESOLUTION ACCEPTING A DEED OF GIFT FROM ROCKING K PROPERTIES, LLC FOR A 1,978 SQUARE FOOT PARCEL IN THE VICINITY OF WEST FIRST STREET AND NICHOLS AVENUE.

RESOLUTION NO. 23-60

A RESOLUTION AUTHORIZING THE FIRST AMENDMENT OF THE EMPLOYMENT AGREEMENT WITH JAMES CARTER NAPIER, FOR CITY MANAGER SERVICES.

RESOLUTION NO. 23-61

A RESOLUTION AUTHORIZING ACCEPTANCE OF A GRANT FROM WYOMING GAME AND FISH COMMISSION WALLOP BREAUX BOATING ACCESS FUND.

RESOLUTION NO. 23-62

A RESOLUTION AUTHORIZING THE MAYOR TO SIGN A LETTER OF SUPPORT FOR THE WYOMING FOOD FOR THOUGHT'S GRANT APPLICATION TO THE ROCKY MOUNTAIN POWER BLUE SKY PROGRAM.

RESOLUTION NO. 23-63

A RESOLUTION AUTHORIZING AMENDMENT NO. 1 TO THE MEMORANDUM OF UNDERSTANDING FOR COMMUNITY RECREATION FACILITIES BETWEEN THE CITY OF CASPER, WYOMING AND NATRONA COUNTY SCHOOL DISTRICT.

RESOLUTION NO. 23-64

A RESOLUTION AUTHORIZING A RENTAL AGREEMENT WITH SPUDS BASEBALL CLUB LLC FOR USE OF THE MIKE LANSING BASEBALL STADIUM.

RESOLUTION NO. 23-65

A RESOLUTION AUTHORIZING A RENTAL AGREEMENT WITH CASPER BASEBALL CLUB FOR USE OF THE MIKE LANSING BASEBALL STADIUM.

RESOLUTION NO. 23-66

A RESOLUTION AUTHORIZING CHANGE ORDER NO. 2 FOR MODERN ELECTRIC CO., FOR THE SOLID WASTE CRL

ELECTRICAL SERVICE UPGRADES, PROJECT NO. 21-013.

RESOLUTION NO. 23-67

A RESOLUTION AUTHORIZING AMENDMENT NO. 2 TO THE CONTRACT FOR PROFESSIONAL SERVICES WITH HOLLAND AND HART, LLP FOR PROVIDING LEGAL SERVICES.

RESOLUTION NO. 23-68

A RESOLUTION AUTHORIZING A PROCUREMENT AGREEMENT WITH DANA KEPNER COMPANY OF WYOMING, INC., FOR THE 2023 CASPER PUBLIC UTILITIES MATERIALS PROCUREMENT.

RESOLUTION NO. 23-69

A RESOLUTION AUTHORIZING A PROCUREMENT AGREEMENT WITH FERGUSON ENTERPRISES, LLC, DBA FERGUSON WATERWORKS, FOR THE 2023 CASPER PUBLIC UTILITIES MATERIALS PROCUREMENT.

RESOLUTION NO. 23-70

A RESOLUTION AUTHORIZING CHANGE ORDER NO. 5 TO THE AGREEMENT WITH INSITUFORM TECHNOLOGIES, LLC, FOR A TIME EXTENSION FOR THE NORTH PLATTE SANITARY SEWER REHABILITATION, PROJECT NO. 20-015.

RESOLUTION NO. 23-71

A RESOLUTION RESCINDING RESOLUTION NO. 22-119 – A RESOLUTION AUTHORIZING A PROFESSIONAL SERVICES CONTRACT FOR TRANSIT SERVICES FOR THE CITY OF MILLS, A WYOMING MUNICIPALITY, FOR FISCAL YEAR 2023.

RESOLUTION NO. 23-72

A RESOLUTION AUTHORIZING A TRANSPORTATION SERVICES CONTRACT FOR THE CITY OF MILLS, A WYOMING MUNICIPALITY, FOR FISCAL YEAR 2023.

RESOLUTION NO. 23-73

A RESOLUTION AUTHORIZING A TRANSPORTATION SERVICES CONTRACT FOR TRANSIT SERVICES FOR THE TOWN OF BAR NUNN, A WYOMING MUNICIPALITY, FOR FISCAL YEAR 2023.

RESOLUTION NO. 23-74

A RESOLUTION RATIFYING THE MAYOR'S SIGNATURE AND APPROVING THE ONEWYO II OPIOID SETTLEMENT MEMORANDUM OF AGREEMENT.

RESOLUTION NO. 23-75

A RESOLUTION AUTHORIZING A CONTRACT BETWEEN THE CITY OF CASPER AND AYRES ASSOCIATES FOR THE NORTH PLATTE RIVER PARK NO. 2 SIMPLE MASTER PLAN.

RESOLUTION NO. 23-76

A RESOLUTION AUTHORIZING A CONTRACT WITH AAA LANDSCAPING, LLC, FOR WEED MOWING AND LITTER ABATEMENT.

RESOLUTION NO. 23-77

A RESOLUTION AUTHORIZING A CONTRACT WITH BRIAN'S GO TO SERVICE FOR WEED MOWING AND LITTER ABATEMENT.

RESOLUTION NO. 23-78

A RESOLUTION DECLARING THE INTENT OF THE CITY OF CASPER WYOMING TO CREATE A LOCAL ASSESSMENT DISTRICT NO. 160, CHINOOK TRAIL IMPROVEMENTS IN SAID CITY; TO AUTHORIZE THE CONSTRUCTION OF LOCAL IMPROVEMENTS THEREIN; AND TO ASSESS THE COST OR PORTION THEREOF ON THE PROPERTY BENEFITTED THEREBY.

Councilor Pollock presented the foregoing twenty-four (24) resolutions for adoption. Seconded by Councilor Engebretsen. Motion passed.

10. CONSENT MINUTE ACTION

Moved by Councilor Bond, seconded by Councilor Engebretsen, to, by consent minute action:

1. Authorize the Purchase of One (1) New Turf Utility Vehicle for Use by the Casper Municipal Golf Course;
2. Authorize the Purchase One (1) New Heavy-Duty Crew Cab Chassis 4x4 Truck with Dump Body and Accessories for Use by the Solid Waste Division of the Public Services Department;
3. Authorize the Purchase of a Bauer Unicus 4s Breathing Air Compressor from Wiedner Fire Equipment for Use by the Casper Fire-EMS Department;
4. Authorize the Purchase of a Custom Service Body from Hiway Products for Use by the Casper Fire-EMS Department on Regional Response Deployments;
5. Authorize the Purchase of Ten (10) Scott Hazmat SCBA's, Masks, and Twenty-Six (26) Bottles from SeaWestern for Use by the Casper Fire-EMS Department on Regional Response Hazmat Calls; and,
6. Rejecting All Bids Received for the City Hall Project S.A.F.E. Asbestos Abatement.

Motion passed.

11. INTRODUCTION OF MEASURES AND PROPOSALS

Councilors spoke on meetings and events they attended as well as matters of public interest.

12. ADJOURN INTO EXECUTIVE SESSION

At 7:31 p.m., it was moved by Vice Mayor Pacheco, seconded by Councilor Bond, to adjourn into executive session to discuss land, litigation and personnel. Motion passed.

At 8:49 p.m., there being no further business, Mayor Knell asked for a motion to adjourn the executive session. Moved by Councilor Pollock seconded by Councilor Haskins. Motion passed.

Council opened the meeting to the public.

13. CONSENT RESOLUTION

The following resolution was considered, by consent:

RESOLUTION NO. 23-79
A RESOLUTION RATIFYING THE MAYOR'S SIGNATURE AND
APPROVING A RELEASE AND SETTLEMENT OF CLAIMS.

Mayor called for a motion to approve the consent resolution. Moved by Councilor Pollock, seconded by Councilor Gamroth. Motion passed.

14. ADJOURNMENT

Mayor Knell called for a motion to adjourn the regular meeting. Moved by Councilor Pollock seconded Councilor Gamroth. Motion passed. The meeting was adjourned at 8:49 p.m.

ATTEST:

CITY OF CASPER, WYOMING
A Municipal Corporation

Fleur Tremel
City Clerk

Bruce Knell
Mayor

City of Casper - Bills and Claims for May 02, 2023

2530 - CPS DSTRBTRS

2530 - CPS DSTRBTRS	Golf - Operations	Ball Valve, 90, coupling - For yard line	\$98.30
<i>2530 - CPS DSTRBTRS - Total For Golf - Operations</i>			<i>\$98.30</i>
2530 - CPS DSTRBTRS	Parks - Urban Forestry	marking paint	\$114.25
<i>2530 - CPS DSTRBTRS - Total For Parks - Urban Forestry</i>			<i>\$114.25</i>
2530 - CPS DSTRBTRS	Water Tanks	PRATT BOOSTER- BOOSTER STATION SUPPLI	\$10.78
2530 - CPS DSTRBTRS	Water Tanks	PRATT BOOSTER- BOOSTER STATION SUPPLI	\$162.07
2530 - CPS DSTRBTRS	Water Tanks	CREDIT PRATT BOOSTER- BOOSTER STATION	(\$63.16)
<i>2530 - CPS DSTRBTRS - Total For Water Tanks</i>			<i>\$109.69</i>
2530 - CPS DSTRBTRS - ALL DEPARTMENTS			\$322.24

307 JANITORIAL LLC

307 JANITORIAL LLC	Buildings & Structures Fund	Cleaning / Janitorial Service	\$3,536.00
<i>307 JANITORIAL LLC - Total For Buildings & Structures Fund</i>			<i>\$3,536.00</i>
307 JANITORIAL LLC - ALL DEPARTMENTS			\$3,536.00

3540 - SUN COUNTRY D

3540 - SUN COUNTRY D	Aquatics - Operations	Freight for Chemicals	\$115.68
<i>3540 - SUN COUNTRY D - Total For Aquatics - Operations</i>			<i>\$115.68</i>
3540 - SUN COUNTRY D - ALL DEPARTMENTS			\$115.68

4IMPRINT, INC

4IMPRINT, INC	Rec Center - Classes	CRC Staff shirts -summer	\$316.60
4IMPRINT, INC	Rec Center - Classes	CRC Staff Shirts-Summer	\$346.61
<i>4IMPRINT, INC - Total For Rec Center - Classes</i>			<i>\$663.21</i>
4IMPRINT, INC	Rec Center - Operations	CRC Staff shirts	\$809.81
<i>4IMPRINT, INC - Total For Rec Center - Operations</i>			<i>\$809.81</i>
4IMPRINT, INC - ALL DEPARTMENTS			\$1,473.02

6H GROUP LLC

6H GROUP LLC	Metro Animal Shelter	Dog & Puppy Food	\$562.10
6H GROUP LLC	Metro Animal Shelter	Cat, Dog & Puppy Food	\$883.10
6H GROUP LLC	Metro Animal Shelter	Dog & Cat Food	\$567.70
6H GROUP LLC	Metro Animal Shelter	Dog Food	(\$69.20)
<i>6H GROUP LLC - Total For Metro Animal Shelter</i>			<i>\$1,943.70</i>
6H GROUP LLC	Police Administration	Dog food	\$231.20
6H GROUP LLC	Police Administration	Dog Food	\$173.40
6H GROUP LLC	Police Administration	Dog food	\$115.60
<i>6H GROUP LLC - Total For Police Administration</i>			<i>\$520.20</i>
6H GROUP LLC - ALL DEPARTMENTS			\$2,463.90

71 CONSTRUCTION, INC

71 CONSTRUCTION, INC	Streets	1/2" Hot Mix Asphalt	\$174.72
<i>71 CONSTRUCTION, INC - Total For Streets</i>			<i>\$174.72</i>
71 CONSTRUCTION, INC - ALL DEPARTMENTS			\$174.72

A.M.B.I. & SHIPPING,

A.M.B.I. & SHIPPING,	City Manager	Postage / Mailing Service	\$2.07
<i>A.M.B.I. & SHIPPING, - Total For City Manager</i>			<i>\$2.07</i>
A.M.B.I. & SHIPPING,	Customer Service	Postage / Mailing Service	\$66.00
A.M.B.I. & SHIPPING,	Customer Service	Postage / Mailing Service	\$666.07
<i>A.M.B.I. & SHIPPING, - Total For Customer Service</i>			<i>\$732.07</i>
A.M.B.I. & SHIPPING,	Ft. Caspar Museum	Postage / Mailing Service	\$10.42
<i>A.M.B.I. & SHIPPING, - Total For Ft. Caspar Museum</i>			<i>\$10.42</i>
A.M.B.I. & SHIPPING,	Municipal Court	Postage / Mailing Service	\$557.97
<i>A.M.B.I. & SHIPPING, - Total For Municipal Court</i>			<i>\$557.97</i>
A.M.B.I. & SHIPPING,	Police Administration	Postage / Mailing Service	\$366.97
A.M.B.I. & SHIPPING,	Police Administration	Postage / Mailing Service	\$338.78
<i>A.M.B.I. & SHIPPING, - Total For Police Administration</i>			<i>\$705.75</i>
A.M.B.I. & SHIPPING,	Risk Management	Postage / Mailing Service	\$2.07
<i>A.M.B.I. & SHIPPING, - Total For Risk Management</i>			<i>\$2.07</i>
A.M.B.I. & SHIPPING, - ALL DEPARTMENTS			\$2,010.35

AED SUPERSTORE

AED SUPERSTORE	Fire-EMS Operations	Suction Canisters (Two charges for One Invoi	\$85.15
<i>AED SUPERSTORE - Total For Fire-EMS Operations</i>			\$85.15
AED SUPERSTORE - ALL DEPARTMENTS			\$85.15

AFFORDABLE FUNERAL S

AFFORDABLE FUNERAL S	Cemetery	turf mats	\$3,999.97
<i>AFFORDABLE FUNERAL S - Total For Cemetery</i>			\$3,999.97
AFFORDABLE FUNERAL S - ALL DEPARTMENTS			\$3,999.97

AIR INNOVATIONS

AIR INNOVATIONS	Balefill - Disposal & Landfill	Maintenance and Filter Change FOR LANDFIL	\$845.00
<i>AIR INNOVATIONS - Total For Balefill - Disposal & Landfill</i>			\$845.00
AIR INNOVATIONS - ALL DEPARTMENTS			\$845.00

AIRGAS LLC -CENTRAL

AIRGAS LLC -CENTRAL	Refuse - Residential	GLASS LENS WIPES FOR TRUCK BARN	\$20.56
<i>AIRGAS LLC -CENTRAL - Total For Refuse - Residential</i>			\$20.56
AIRGAS LLC -CENTRAL - ALL DEPARTMENTS			\$20.56

AIRGAS USA LLC

AIRGAS USA LLC	Balefill - Baler Processing	Scratch brush, WELDING COMSUMABLES	\$46.87
<i>AIRGAS USA LLC - Total For Balefill - Baler Processing</i>			\$46.87
AIRGAS USA LLC	Balefill - Disposal & Landfill	LEATHER GLOVES FOR SPECIAL WASTE Oper	\$120.75
AIRGAS USA LLC	Balefill - Disposal & Landfill	Magnifying Glass for Welding Helmet	\$26.44
<i>AIRGAS USA LLC - Total For Balefill - Disposal & Landfill</i>			\$147.19
AIRGAS USA LLC	Balefill - Diversion & Special	CUTTING TORCH FOR COMPOST BUILDING	\$174.57
<i>AIRGAS USA LLC - Total For Balefill - Diversion & Special</i>			\$174.57
AIRGAS USA LLC	Police Investigations	Respiratory masks & wipes	\$52.88
<i>AIRGAS USA LLC - Total For Police Investigations</i>			\$52.88
AIRGAS USA LLC - ALL DEPARTMENTS			\$421.51

ALBANY RESTAURANT BA

ALBANY RESTAURANT BA	Health Insurance Fund	2023 Workforce Summit - Cheyenne	\$22.98
<i>ALBANY RESTAURANT BA - Total For Health Insurance Fund</i>			<i>\$22.98</i>
ALBANY RESTAURANT BA - ALL DEPARTMENTS			\$22.98

ALBERTSONS #0062

ALBERTSONS #0062	Balefill - Disposal & Landfill	SAFETY SUPPLIES	\$12.58
<i>ALBERTSONS #0062 - Total For Balefill - Disposal & Landfill</i>			<i>\$12.58</i>
ALBERTSONS #0062	Buildings & Structures Fund	Repair supplies for Ice Arena - Albertsons	\$17.88
<i>ALBERTSONS #0062 - Total For Buildings & Structures Fund</i>			<i>\$17.88</i>
ALBERTSONS #0062	WWTP Operations	Coffee	\$29.98
<i>ALBERTSONS #0062 - Total For WWTP Operations</i>			<i>\$29.98</i>
ALBERTSONS #0062 - ALL DEPARTMENTS			\$60.44

ALL AMERICAN SPORTS

ALL AMERICAN SPORTS	Parks - Athletic Maint.	All American Gold Infield	\$4,182.70
<i>ALL AMERICAN SPORTS - Total For Parks - Athletic Maint.</i>			<i>\$4,182.70</i>
ALL AMERICAN SPORTS - ALL DEPARTMENTS			\$4,182.70

ALSCO

ALSCO	Balefill - Disposal & Landfill	Professional Laundry Services	\$193.66
ALSCO	Balefill - Disposal & Landfill	Professional Laundry Services	\$63.17
ALSCO	Balefill - Disposal & Landfill	Professional Laundry Services	\$99.98
ALSCO	Balefill - Disposal & Landfill	Professional Laundry Services	\$58.82
<i>ALSCO - Total For Balefill - Disposal & Landfill</i>			<i>\$415.63</i>
ALSCO	Refuse - Residential	Professional Laundry Services	\$92.66
<i>ALSCO - Total For Refuse - Residential</i>			<i>\$92.66</i>
ALSCO	Regional Water Operations	Professional Laundry Services	\$41.41
<i>ALSCO - Total For Regional Water Operations</i>			<i>\$41.41</i>
ALSCO	Sewer Wastewater Collection	Professional Laundry Services	\$44.18
ALSCO	Sewer Wastewater Collection	Professional Laundry Services	\$44.18
ALSCO	Sewer Wastewater Collection	Professional Laundry Services	\$44.18
<i>ALSCO - Total For Sewer Wastewater Collection</i>			<i>\$132.54</i>

ALSCO	WWTP Operations	Professional Laundry Services	\$152.38
ALSCO	WWTP Operations	Professional Laundry Services	\$152.38
ALSCO	WWTP Operations	Professional Laundry Services	\$152.38
<i>ALSCO - Total For WWTP Operations</i>			<i>\$457.14</i>
ALSCO - ALL DEPARTMENTS			\$1,139.38

ALSCO INDUSTRIAL PRO

ALSCO INDUSTRIAL PRO	WWTP Regional Interceptors	Valve	\$882.18
<i>ALSCO INDUSTRIAL PRO - Total For WWTP Regional Interceptors</i>			<i>\$882.18</i>
ALSCO INDUSTRIAL PRO - ALL DEPARTMENTS			\$882.18

ALUMITECH LLC

ALUMITECH LLC	Buildings & Structures Fund	Battery replacements on sliding automatic d	\$325.87
ALUMITECH LLC	Buildings & Structures Fund	Storefront door repair & materials	\$373.13
<i>ALUMITECH LLC - Total For Buildings & Structures Fund</i>			<i>\$699.00</i>
ALUMITECH LLC - ALL DEPARTMENTS			\$699.00

AMAZON.COM H77PF15L0

AMAZON.COM H77PF15L0	Police Administration	BOOK STORES Fleet	\$149.95
<i>AMAZON.COM H77PF15L0 - Total For Police Administration</i>			<i>\$149.95</i>
AMAZON.COM H77PF15L0 - ALL DEPARTMENTS			\$149.95

AMAZON.COM HC4VI47Z2

AMAZON.COM HC4VI47Z2	Police Administration	BOOK STORES dry erase board CS	\$26.53
<i>AMAZON.COM HC4VI47Z2 - Total For Police Administration</i>			<i>\$26.53</i>
AMAZON.COM HC4VI47Z2 - ALL DEPARTMENTS			\$26.53

AMAZON.COM HJ6IX5X90

AMAZON.COM HJ6IX5X90	Aquatics - Operations	Special Guard Suit	\$24.05
<i>AMAZON.COM HJ6IX5X90 - Total For Aquatics - Operations</i>			<i>\$24.05</i>
AMAZON.COM HJ6IX5X90 - ALL DEPARTMENTS			\$24.05

AMAZON.COM HY2CD72Z2

AMAZON.COM HY2CD72Z2	Rec Center - Classes	CRC Program Supplies; Summer Dodgeballs	\$1,163.30
<i>AMAZON.COM HY2CD72Z2 - Total For Rec Center - Classes</i>			<i>\$1,163.30</i>
AMAZON.COM HY2CD72Z2 - ALL DEPARTMENTS			\$1,163.30

AMERICAN RED CROSS

AMERICAN RED CROSS	Aquatics - Operations	Lifeguard Certifications	\$128.00
<i>AMERICAN RED CROSS - Total For Aquatics - Operations</i>			<i>\$128.00</i>
AMERICAN RED CROSS	Aquatics- Marion Kreiner Op	Lifeguard Certifications	\$68.00
<i>AMERICAN RED CROSS - Total For Aquatics- Marion Kreiner Oper.</i>			<i>\$68.00</i>
AMERICAN RED CROSS	Aquatics- Mike Sedar Oper.	Lifeguard Certifications	\$224.00
<i>AMERICAN RED CROSS - Total For Aquatics- Mike Sedar Oper.</i>			<i>\$224.00</i>
AMERICAN RED CROSS - ALL DEPARTMENTS			\$420.00

AMERICAN SOCIETY OF

AMERICAN SOCIETY OF	Risk Management	CHARITABLE AND SOCIAL SERVICE ORGANIZ	\$220.00
<i>AMERICAN SOCIETY OF - Total For Risk Management</i>			<i>\$220.00</i>
AMERICAN SOCIETY OF - ALL DEPARTMENTS			\$220.00

AMZN Mktp US

AMZN Mktp US	Aquatics - Operations	Respirator	\$972.00
<i>AMZN Mktp US - Total For Aquatics - Operations</i>			<i>\$972.00</i>
AMZN Mktp US	Balefill - Disposal & Landfill	BATTERY FOR CITY DIVISION CAMERA	\$21.47
<i>AMZN Mktp US - Total For Balefill - Disposal & Landfill</i>			<i>\$21.47</i>
AMZN Mktp US	Community Development	BOOK STORES	\$116.98
<i>AMZN Mktp US - Total For Community Development</i>			<i>\$116.98</i>
AMZN Mktp US	Police Administration	BOOK STORES whiteboard tape	\$5.93
<i>AMZN Mktp US - Total For Police Administration</i>			<i>\$5.93</i>
AMZN Mktp US	Rec Center - Classes	CRC Program supplies; Party Rentals	\$105.98
<i>AMZN Mktp US - Total For Rec Center - Classes</i>			<i>\$105.98</i>
AMZN Mktp US	Water Meters	IPAD CASE, HANGING KEY TAG- TECHNOLOG	\$90.96
<i>AMZN Mktp US - Total For Water Meters</i>			<i>\$90.96</i>

AMZN Mktp US - ALL DEPARTMENTS \$1,313.32

ANDREEN HUNT CONSTRU

ANDREEN HUNT CONSTRU Streets Snow plowing \$4,025.00

ANDREEN HUNT CONSTRU - Total For Streets \$4,025.00

ANDREEN HUNT CONSTRU - ALL DEPARTMENTS \$4,025.00

APCO INTERNATIONAL I

APCO INTERNATIONAL I Public Safety Communication BUSINESS SERVICES NOT ELSEWHERE CLASSI \$935.00

APCO INTERNATIONAL I - Total For Public Safety Communications \$935.00

APCO INTERNATIONAL I - ALL DEPARTMENTS \$935.00

APPLE COMPUTER, INC.

APPLE COMPUTER, INC. Fire-EMS Administration iCloud Storage \$0.99

APPLE COMPUTER, INC. - Total For Fire-EMS Administration \$0.99

APPLE COMPUTER, INC. - ALL DEPARTMENTS \$0.99

APSTYLEBOOK.COM

APSTYLEBOOK.COM City Manager AP Styleguide Workshop \$299.00

APSTYLEBOOK.COM - Total For City Manager \$299.00

APSTYLEBOOK.COM - ALL DEPARTMENTS \$299.00

ARBY'S 7533

ARBY'S 7533 Regional Water Operations JPB Meeting Lunch - Office Supplies \$84.10

ARBY'S 7533 - Total For Regional Water Operations \$84.10

ARBY'S 7533 - ALL DEPARTMENTS \$84.10

ARMORS RESTAURANT IN

ARMORS RESTAURANT IN Police Administration EATING PLACES, RESTAURANTS Awards cere \$2,187.67

ARMORS RESTAURANT IN - Total For Police Administration \$2,187.67

ARMORS RESTAURANT IN - ALL DEPARTMENTS

\$2,187.67

AT & T CORP

AT & T CORP	Police Investigations	LEA Tracking - CR# 23-015089	\$70.00
-------------	-----------------------	------------------------------	---------

<i>AT & T CORP - Total For Police Investigations</i>			\$70.00
--	--	--	---------

AT & T CORP	Public Transit - CARES Act	Acct #287306431868	\$291.16
-------------	----------------------------	--------------------	----------

<i>AT & T CORP - Total For Public Transit - CARES Act</i>			\$291.16
---	--	--	----------

AT & T CORP	Sewer Wastewater Collection	Acct #287295228508--remote device data	\$160.16
-------------	-----------------------------	--	----------

<i>AT & T CORP - Total For Sewer Wastewater Collection</i>			\$160.16
--	--	--	----------

AT & T CORP	Streets	Acct #287294643026	\$200.20
-------------	---------	--------------------	----------

<i>AT & T CORP - Total For Streets</i>			\$200.20
--	--	--	----------

AT & T CORP - ALL DEPARTMENTS

\$721.52

ATLANTIC ELECTRIC, I

ATLANTIC ELECTRIC, I	Water Tanks	Installation of fan - parts & labor	\$398.20
----------------------	-------------	-------------------------------------	----------

<i>ATLANTIC ELECTRIC, I - Total For Water Tanks</i>			\$398.20
---	--	--	----------

ATLANTIC ELECTRIC, I - ALL DEPARTMENTS

\$398.20

ATLAS OFFICE PRODUCT

ATLAS OFFICE PRODUCT	Balefill - Disposal & Landfill	Office supplies for scale house	\$26.26
----------------------	--------------------------------	---------------------------------	---------

ATLAS OFFICE PRODUCT	Balefill - Disposal & Landfill	Office supplies for scale house	\$14.54
----------------------	--------------------------------	---------------------------------	---------

ATLAS OFFICE PRODUCT	Balefill - Disposal & Landfill	Office supplies of scalehouse	\$5.60
----------------------	--------------------------------	-------------------------------	--------

ATLAS OFFICE PRODUCT	Balefill - Disposal & Landfill	Office supplies of scalehouse	\$1,162.64
----------------------	--------------------------------	-------------------------------	------------

<i>ATLAS OFFICE PRODUCT - Total For Balefill - Disposal & Landfill</i>			\$1,209.04
--	--	--	------------

ATLAS OFFICE PRODUCT	Balefill - Diversion & Special	DESK FOR OFFICE AT SPECIAL WASTE	\$375.00
----------------------	--------------------------------	----------------------------------	----------

ATLAS OFFICE PRODUCT	Balefill - Diversion & Special	Office supplies for compost sell	\$8.22
----------------------	--------------------------------	----------------------------------	--------

<i>ATLAS OFFICE PRODUCT - Total For Balefill - Diversion & Special</i>			\$383.22
--	--	--	----------

ATLAS OFFICE PRODUCT	City Clerk	COMMERCIAL EQUIPMENT, NOT ELSEWHERE	\$57.05
----------------------	------------	-------------------------------------	---------

ATLAS OFFICE PRODUCT	City Clerk	COMMERCIAL EQUIPMENT, NOT ELSEWHERE	\$49.99
----------------------	------------	-------------------------------------	---------

<i>ATLAS OFFICE PRODUCT - Total For City Clerk</i>			\$107.04
--	--	--	----------

ATLAS OFFICE PRODUCT	Customer Service	COFFEE CREAMER	\$3.56
----------------------	------------------	----------------	--------

<i>ATLAS OFFICE PRODUCT - Total For Customer Service</i>			\$3.56
--	--	--	--------

ATLAS OFFICE PRODUCT	Engineering	REFUND FOR LABEL TAPE	(\$22.12)
----------------------	-------------	-----------------------	-----------

ATLAS OFFICE PRODUCT	Engineering	LABEL MAKER TAPE	\$31.84
<i>ATLAS OFFICE PRODUCT - Total For Engineering</i>			\$9.72
ATLAS OFFICE PRODUCT	Finance	COFFEE CREAMER	\$3.56
ATLAS OFFICE PRODUCT	Finance	3 HOLE PUNCH	\$221.43
<i>ATLAS OFFICE PRODUCT - Total For Finance</i>			\$224.99
ATLAS OFFICE PRODUCT	Health Insurance Fund	COFFEE CREAMER	\$7.14
<i>ATLAS OFFICE PRODUCT - Total For Health Insurance Fund</i>			\$7.14
ATLAS OFFICE PRODUCT	Human Resources	COFFEE CREAMER	\$3.58
<i>ATLAS OFFICE PRODUCT - Total For Human Resources</i>			\$3.58
ATLAS OFFICE PRODUCT	Information Services	Monitor stands for Szewczyk, Zieger	\$101.81
<i>ATLAS OFFICE PRODUCT - Total For Information Services</i>			\$101.81
ATLAS OFFICE PRODUCT	Metro Animal Shelter	Office supplies	\$40.74
ATLAS OFFICE PRODUCT	Metro Animal Shelter	Office supplies	\$34.54
ATLAS OFFICE PRODUCT	Metro Animal Shelter	Office supplies	\$69.08
<i>ATLAS OFFICE PRODUCT - Total For Metro Animal Shelter</i>			\$144.36
ATLAS OFFICE PRODUCT	Municipal Court	Office supplies	\$21.83
ATLAS OFFICE PRODUCT	Municipal Court	Office supplies	\$57.69
<i>ATLAS OFFICE PRODUCT - Total For Municipal Court</i>			\$79.52
ATLAS OFFICE PRODUCT	Police Administration	Office supplies	\$46.10
ATLAS OFFICE PRODUCT	Police Administration	Office supplies	\$20.64
ATLAS OFFICE PRODUCT	Police Administration	Office supplies	\$194.54
ATLAS OFFICE PRODUCT	Police Administration	Office supplies	\$5.96
ATLAS OFFICE PRODUCT	Police Administration	Office supplies	\$20.31
<i>ATLAS OFFICE PRODUCT - Total For Police Administration</i>			\$287.55
ATLAS OFFICE PRODUCT	Regional Water Operations	Book Rings - Office Supplies	\$13.31
ATLAS OFFICE PRODUCT	Regional Water Operations	Business Card Holder - Office Supplies	\$12.99
ATLAS OFFICE PRODUCT	Regional Water Operations	Dish Soap, Paper Towels, & Facial Tissues - O	\$559.57
<i>ATLAS OFFICE PRODUCT - Total For Regional Water Operations</i>			\$585.87
ATLAS OFFICE PRODUCT - ALL DEPARTMENTS			\$3,147.40

ATLAS REPRODUCTION

ATLAS REPRODUCTION	Balefill - Diversion & Special	Home and Garden Show Booth materials Bal	\$23.00
<i>ATLAS REPRODUCTION - Total For Balefill - Diversion & Special</i>			\$23.00
ATLAS REPRODUCTION	Community Development	Printing / Laminating Service	\$30.00
<i>ATLAS REPRODUCTION - Total For Community Development</i>			\$30.00

ATLAS REPRODUCTION	Fire-EMS Administration	Copier usage	\$36.38
<i>ATLAS REPRODUCTION - Total For Fire-EMS Administration</i>			<i>\$36.38</i>
ATLAS REPRODUCTION	Regional Water Operations	Scans to PDF - Postage & Printing	\$115.60
<i>ATLAS REPRODUCTION - Total For Regional Water Operations</i>			<i>\$115.60</i>
ATLAS REPRODUCTION - ALL DEPARTMENTS			\$204.98

BACKFLOW APPARATUS &

BACKFLOW APPARATUS &	RWS - Booster Stations	BACK FLOW REPAIR KIT- REGIONAL BOOSTER	\$72.40
<i>BACKFLOW APPARATUS & - Total For RWS - Booster Stations</i>			<i>\$72.40</i>
BACKFLOW APPARATUS &	Weed & Pest Fund	Backflow repair chemical shed	\$170.90
<i>BACKFLOW APPARATUS & - Total For Weed & Pest Fund</i>			<i>\$170.90</i>
BACKFLOW APPARATUS & - ALL DEPARTMENTS			\$243.30

BADGER METER INC

BADGER METER INC	Water Meters	Meter 66220-009 Interface Configuration	\$562.50
<i>BADGER METER INC - Total For Water Meters</i>			<i>\$562.50</i>
BADGER METER INC - ALL DEPARTMENTS			\$562.50

BAILEYS ACE HDWE

BAILEYS ACE HDWE	Balefill - Diversion & Special	key organizer/ key cabinet for special waste	\$31.97
<i>BAILEYS ACE HDWE - Total For Balefill - Diversion & Special</i>			<i>\$31.97</i>
BAILEYS ACE HDWE	Buildings & Structures Fund	Ice Maker Repair supplies for Casper Soccer -	\$16.98
BAILEYS ACE HDWE	Buildings & Structures Fund	Plumbing repair supplies for Rec Center - Bail	\$43.50
BAILEYS ACE HDWE	Buildings & Structures Fund	Key copies for SAFE project move - Baileys A	\$15.96
BAILEYS ACE HDWE	Buildings & Structures Fund	Key copies for SAFE project - Baileys Ace	\$33.48
<i>BAILEYS ACE HDWE - Total For Buildings & Structures Fund</i>			<i>\$109.92</i>
BAILEYS ACE HDWE	Fire-EMS Training	Material for VES training	\$15.98
<i>BAILEYS ACE HDWE - Total For Fire-EMS Training</i>			<i>\$15.98</i>
BAILEYS ACE HDWE	Refuse - Commercial	SUPPLIES FOR TRUCK BARN, TAPE SHOVEL A	\$132.90
<i>BAILEYS ACE HDWE - Total For Refuse - Commercial</i>			<i>\$132.90</i>
BAILEYS ACE HDWE - ALL DEPARTMENTS			\$290.77

BARGREEN ELLINGSON

BARGREEN ELLINGSON	Balefill - Disposal & Landfill	Hand soap SCALEHOUSE/BALERBLDG/TRUCK	\$51.11
<i>BARGREEN ELLINGSON - Total For Balefill - Disposal & Landfill</i>			<i>\$51.11</i>
BARGREEN ELLINGSON	Balefill - Diversion & Special	Hand soap SCALEHOUSE/BALERBLDG/TRUCK	\$51.12
<i>BARGREEN ELLINGSON - Total For Balefill - Diversion & Special</i>			<i>\$51.12</i>
BARGREEN ELLINGSON - ALL DEPARTMENTS			\$102.23

BARGREEN WYOMING

BARGREEN WYOMING	Golf - Operations	Toilet Paper and Center Pull paper towels	\$248.00
<i>BARGREEN WYOMING - Total For Golf - Operations</i>			<i>\$248.00</i>
BARGREEN WYOMING - ALL DEPARTMENTS			\$248.00

BEARDSLEY SAM STABLE

BEARDSLEY SAM STABLE	Hogadon - Operations	Ski area management subscription	\$110.00
<i>BEARDSLEY SAM STABLE - Total For Hogadon - Operations</i>			<i>\$110.00</i>
BEARDSLEY SAM STABLE - ALL DEPARTMENTS			\$110.00

BEST BUY

BEST BUY	Metropolitan Planning Org	ELECTRONIC SALES- new monitor for Salina	\$109.99
<i>BEST BUY - Total For Metropolitan Planning Org</i>			<i>\$109.99</i>
BEST BUY - ALL DEPARTMENTS			\$109.99

BLACK HILLS ENERGY

BLACK HILLS ENERGY	Aquatics - Operations	Acct #7584 6122 74	\$11,988.67
<i>BLACK HILLS ENERGY - Total For Aquatics - Operations</i>			<i>\$11,988.67</i>
BLACK HILLS ENERGY	Aquatics- Marion Kreiner Op	Acct #9723 1947 06	\$111.00
<i>BLACK HILLS ENERGY - Total For Aquatics- Marion Kreiner Oper.</i>			<i>\$111.00</i>
BLACK HILLS ENERGY	Aquatics- Mike Sedar Oper.	Acct #9723 1947 06	\$82.00
<i>BLACK HILLS ENERGY - Total For Aquatics- Mike Sedar Oper.</i>			<i>\$82.00</i>
BLACK HILLS ENERGY	Aquatics- Paradise Valley Op	Acct #9723 1947 06	\$82.00
<i>BLACK HILLS ENERGY - Total For Aquatics- Paradise Valley Oper</i>			<i>\$82.00</i>
BLACK HILLS ENERGY	Aquatics- Washington Oper	Acct #9723 1947 06	\$82.00
<i>BLACK HILLS ENERGY - Total For Aquatics- Washington Oper</i>			<i>\$82.00</i>
BLACK HILLS ENERGY	Ash Street Building	Acct #4376 8927 11	\$1,298.36

<i>BLACK HILLS ENERGY - Total For Ash Street Building</i>			\$1,298.36
BLACK HILLS ENERGY	Balefill - Disposal & Landfill	Acct #1919 8530 97	\$9,730.20
<i>BLACK HILLS ENERGY - Total For Balefill - Disposal & Landfill</i>			\$9,730.20
BLACK HILLS ENERGY	Buildings & Structures Fund	Acct #8545 6521 02	\$646.68
<i>BLACK HILLS ENERGY - Total For Buildings & Structures Fund</i>			\$646.68
BLACK HILLS ENERGY	Casper Business Center	Acct #4620 7426 21	\$2,564.36
<i>BLACK HILLS ENERGY - Total For Casper Business Center</i>			\$2,564.36
BLACK HILLS ENERGY	Cemetery	Acct #9629 0042 60	\$737.24
<i>BLACK HILLS ENERGY - Total For Cemetery</i>			\$737.24
BLACK HILLS ENERGY	City Center Building	Acct #8545 6521 02	\$218.01
<i>BLACK HILLS ENERGY - Total For City Center Building</i>			\$218.01
BLACK HILLS ENERGY	City Hall	Acct #6837 4281 65	\$3,160.35
<i>BLACK HILLS ENERGY - Total For City Hall</i>			\$3,160.35
BLACK HILLS ENERGY	Fire-EMS Administration	Acct #3267 4234 58	\$758.81
BLACK HILLS ENERGY	Fire-EMS Administration	Acct #1783 9430 41	\$5,039.44
<i>BLACK HILLS ENERGY - Total For Fire-EMS Administration</i>			\$5,798.25
BLACK HILLS ENERGY	Fleet Maintenance Fund	Acct #5293 6421 13	\$6,761.11
<i>BLACK HILLS ENERGY - Total For Fleet Maintenance Fund</i>			\$6,761.11
BLACK HILLS ENERGY	Ft. Caspar Museum	Acct #9861 5264 23	\$960.04
<i>BLACK HILLS ENERGY - Total For Ft. Caspar Museum</i>			\$960.04
BLACK HILLS ENERGY	Golf - Operations	Acct #6566 7661 30	\$511.96
BLACK HILLS ENERGY	Golf - Operations	Acct #1340 9824 25	\$66.66
<i>BLACK HILLS ENERGY - Total For Golf - Operations</i>			\$578.62
BLACK HILLS ENERGY	Ice Arena - Operations	Acct #9570 6006 61	\$2,337.04
<i>BLACK HILLS ENERGY - Total For Ice Arena - Operations</i>			\$2,337.04
BLACK HILLS ENERGY	Marathon Building	Acct #8545 6521 02	\$1,656.74
<i>BLACK HILLS ENERGY - Total For Marathon Building</i>			\$1,656.74
BLACK HILLS ENERGY	Metro Animal Shelter	Acct #9630 2229 58	\$2,024.57
<i>BLACK HILLS ENERGY - Total For Metro Animal Shelter</i>			\$2,024.57
BLACK HILLS ENERGY	Miller St. Dormitory	Acct #8545 6521 02	\$270.72
<i>BLACK HILLS ENERGY - Total For Miller St. Dormitory</i>			\$270.72
BLACK HILLS ENERGY	Parks - Athletic Maint.	Acct #5655 3404 55	\$222.36
<i>BLACK HILLS ENERGY - Total For Parks - Athletic Maint.</i>			\$222.36
BLACK HILLS ENERGY	Parks - Parks Maint.	Acct #2076 2356 87	\$282.11
<i>BLACK HILLS ENERGY - Total For Parks - Parks Maint.</i>			\$282.11
BLACK HILLS ENERGY	Public Transit - CARES Act	Acct #3470 5680 29	\$254.71

<i>BLACK HILLS ENERGY - Total For Public Transit - CARES Act</i>			\$254.71
BLACK HILLS ENERGY	Rec Center - Operations	Acct #4400 2150 46	\$5,829.46
<i>BLACK HILLS ENERGY - Total For Rec Center - Operations</i>			\$5,829.46
BLACK HILLS ENERGY	Regional Water Operations	Acct #7513 1659 94 - Natural Gas	\$12,680.13
<i>BLACK HILLS ENERGY - Total For Regional Water Operations</i>			\$12,680.13
BLACK HILLS ENERGY	Sewer Wastewater Collection	Acct #6405 5357 61 lift station natural gas	\$34.39
<i>BLACK HILLS ENERGY - Total For Sewer Wastewater Collection</i>			\$34.39
BLACK HILLS ENERGY	WWTP Operations	Acct #5541 2887 44	\$11,090.82
<i>BLACK HILLS ENERGY - Total For WWTP Operations</i>			\$11,090.82
BLACK HILLS ENERGY - ALL DEPARTMENTS			\$81,481.94

BLAKEMAN PROPANE

BLAKEMAN PROPANE	Balefill - Disposal & Landfill	Propane HEAT FOR EQUIPT BLDG	\$664.22
BLAKEMAN PROPANE	Balefill - Disposal & Landfill	Propane FOR LANDFILL BLDG	\$445.07
BLAKEMAN PROPANE	Balefill - Disposal & Landfill	Propane to Heat Landfill Bldg	\$928.20
<i>BLAKEMAN PROPANE - Total For Balefill - Disposal & Landfill</i>			\$2,037.49
BLAKEMAN PROPANE	Hogadon - Operations	Propane	\$750.00
BLAKEMAN PROPANE	Hogadon - Operations	Propane	\$742.55
<i>BLAKEMAN PROPANE - Total For Hogadon - Operations</i>			\$1,492.55
BLAKEMAN PROPANE - ALL DEPARTMENTS			\$3,530.04

BLOEDORN LUMBER CO

BLOEDORN LUMBER CO	Buildings & Structures Fund	BAS Shop supplies and Rec Ctr. Steamer repa	\$99.87
BLOEDORN LUMBER CO	Buildings & Structures Fund	Supplies to repair slats at CBC Entrance - Blo	\$83.88
BLOEDORN LUMBER CO	Buildings & Structures Fund	Repair supplies for CBC HVAC Equipment - BI	\$10.69
<i>BLOEDORN LUMBER CO - Total For Buildings & Structures Fund</i>			\$194.44
BLOEDORN LUMBER CO - ALL DEPARTMENTS			\$194.44

BRIDGEPAY NETWORK SO

BRIDGEPAY NETWORK SO	City Clerk	CREDIT CARD FEES	\$38.28
<i>BRIDGEPAY NETWORK SO - Total For City Clerk</i>			\$38.28
BRIDGEPAY NETWORK SO	Community Development	CREDIT CARD FEES	\$38.26
<i>BRIDGEPAY NETWORK SO - Total For Community Development</i>			\$38.26

BRIDGEPAY NETWORK SO	Engineering	CREDIT CARD FEES	\$38.26
<i>BRIDGEPAY NETWORK SO - Total For Engineering</i>			\$38.26
BRIDGEPAY NETWORK SO - ALL DEPARTMENTS			\$114.80

BUDGET RENT A CAR

BUDGET RENT A CAR	Police Career Services	BUDGET RENT-A-CAR Background investigati	\$231.47
<i>BUDGET RENT A CAR - Total For Police Career Services</i>			\$231.47
BUDGET RENT A CAR - ALL DEPARTMENTS			\$231.47

CASELLE, INC.

CASELLE, INC.	Customer Service	Contract Support & Maintenance-5/01/23 to	\$78.00
<i>CASELLE, INC. - Total For Customer Service</i>			\$78.00
CASELLE, INC. - ALL DEPARTMENTS			\$78.00

CASPER COLLEGE

CASPER COLLEGE	City Clerk	COLLEGES, UNIVERSITIES, PROFESSIONAL SC	\$380.00
CASPER COLLEGE	City Clerk	COLLEGES, UNIVERSITIES, PROFESSIONAL SC	\$315.00
CASPER COLLEGE	City Clerk	COLLEGES, UNIVERSITIES, PROFESSIONAL SC	\$315.00
<i>CASPER COLLEGE - Total For City Clerk</i>			\$1,010.00
CASPER COLLEGE - ALL DEPARTMENTS			\$1,010.00

CASPER STAR-TRIBUNE,

CASPER STAR-TRIBUNE,	Capital Projects Fund	Standard Advertisement For Bid	\$620.28
CASPER STAR-TRIBUNE,	Capital Projects Fund	Notice of Final Payment to Contractor	\$147.56
CASPER STAR-TRIBUNE,	Capital Projects Fund	Standard Advertisement For Bid	\$613.96
<i>CASPER STAR-TRIBUNE, - Total For Capital Projects Fund</i>			\$1,381.80
CASPER STAR-TRIBUNE, - ALL DEPARTMENTS			\$1,381.80

CASPER TIRE

CASPER TIRE	Refuse - Commercial	Flat repair TRK#2282 FLATBED TRAILER	\$20.00
CASPER TIRE	Refuse - Commercial	Flat repair TRK#2305 COMMERCIAL ROLL OF	\$45.00
<i>CASPER TIRE - Total For Refuse - Commercial</i>			\$65.00

CASPER TIRE - ALL DEPARTMENTS \$65.00

CASPER WINNELSON CO

CASPER WINNELSON CO	Buildings & Structures Fund	Plumbing repair supplies for Aquatics Center	\$616.60
CASPER WINNELSON CO	Buildings & Structures Fund	Supplies to start up Lansing Field for Season	\$62.81
<i>CASPER WINNELSON CO - Total For Buildings & Structures Fund</i>			\$679.41
CASPER WINNELSON CO	RWS - Booster Stations	TEST PORT- REGIONAL BOOSTER SUPPLIES	\$17.05
<i>CASPER WINNELSON CO - Total For RWS - Booster Stations</i>			\$17.05
CASPER WINNELSON CO	WWTP Operations	PLUMBING Supplies	\$4.74
<i>CASPER WINNELSON CO - Total For WWTP Operations</i>			\$4.74

CASPER WINNELSON CO - ALL DEPARTMENTS \$701.20

CENTRAL TRUCK & DIES

CENTRAL TRUCK & DIES	Regional Water Operations	Sump Pump for Sludge Ponds - Pump & Lubri	\$581.00
<i>CENTRAL TRUCK & DIES - Total For Regional Water Operations</i>			\$581.00

CENTRAL TRUCK & DIES - ALL DEPARTMENTS \$581.00

CENTRAL WY. REGIONAL

CENTRAL WY. REGIONAL	Water Revenue and Transfer	System Investment Charges - March 2023	\$56,829.00
<i>CENTRAL WY. REGIONAL - Total For Water Revenue and Transfers</i>			\$56,829.00

CENTRAL WY. REGIONAL - ALL DEPARTMENTS \$56,829.00

CENTURYLINK

CENTURYLINK	Aquatics - Operations	Acct #P-307-111-9950 456M	\$27.82
<i>CENTURYLINK - Total For Aquatics - Operations</i>			\$27.82
CENTURYLINK	Balefill - Disposal & Landfill	Acct #P-307-111-9950 456M	\$89.48
<i>CENTURYLINK - Total For Balefill - Disposal & Landfill</i>			\$89.48
CENTURYLINK	Buildings & Structures Fund	Acct #P-307-111-9950 456M	\$16.83
<i>CENTURYLINK - Total For Buildings & Structures Fund</i>			\$16.83
CENTURYLINK	Cemetery	Acct #P-307-111-9950 456M	\$16.83
<i>CENTURYLINK - Total For Cemetery</i>			\$16.83
CENTURYLINK	City Attorney	Acct #P-307-111-9950 456M	\$61.49
<i>CENTURYLINK - Total For City Attorney</i>			\$61.49

CENTURYLINK	City Council	Acct #P-307-111-9950 456M	\$16.83
<i>CENTURYLINK - Total For City Council</i>			<i>\$16.83</i>
CENTURYLINK	City Hall	Acct #P-307-111-9950 456M	\$11.16
<i>CENTURYLINK - Total For City Hall</i>			<i>\$11.16</i>
CENTURYLINK	City Manager	Acct #P-307-111-9950 456M	\$39.16
<i>CENTURYLINK - Total For City Manager</i>			<i>\$39.16</i>
CENTURYLINK	Community Development	Acct #P-307-111-9950 456M	\$134.14
<i>CENTURYLINK - Total For Community Development</i>			<i>\$134.14</i>
CENTURYLINK	Customer Service	Acct #P-307-111-9950 456M	\$39.16
<i>CENTURYLINK - Total For Customer Service</i>			<i>\$39.16</i>
CENTURYLINK	Engineering	Acct #P-307-111-9950 456M	\$78.32
<i>CENTURYLINK - Total For Engineering</i>			<i>\$78.32</i>
CENTURYLINK	Finance	Acct #P-307-111-9950 456M	\$89.48
<i>CENTURYLINK - Total For Finance</i>			<i>\$89.48</i>
CENTURYLINK	Fire-EMS Administration	Acct #P-307-111-9950 456M	\$111.81
<i>CENTURYLINK - Total For Fire-EMS Administration</i>			<i>\$111.81</i>
CENTURYLINK	Fleet Maintenance Fund	Acct #P-307-111-9950 456M	\$72.65
<i>CENTURYLINK - Total For Fleet Maintenance Fund</i>			<i>\$72.65</i>
CENTURYLINK	Ft. Caspar Museum	Acct #P-307-111-9950 456M	\$16.83
<i>CENTURYLINK - Total For Ft. Caspar Museum</i>			<i>\$16.83</i>
CENTURYLINK	Golf - Operations	Acct #P-307-111-9950 456M	\$16.84
<i>CENTURYLINK - Total For Golf - Operations</i>			<i>\$16.84</i>
CENTURYLINK	Hogadon - Operations	Acct #P-307-111-9950 456M	\$55.82
<i>CENTURYLINK - Total For Hogadon - Operations</i>			<i>\$55.82</i>
CENTURYLINK	Human Resources	Acct #P-307-111-9950 456M	\$28.00
<i>CENTURYLINK - Total For Human Resources</i>			<i>\$28.00</i>
CENTURYLINK	Ice Arena - Operations	Acct #P-307-111-9950 456M	\$22.33
<i>CENTURYLINK - Total For Ice Arena - Operations</i>			<i>\$22.33</i>
CENTURYLINK	Information Services	Acct #P-307-111-9950 456M	\$89.48
<i>CENTURYLINK - Total For Information Services</i>			<i>\$89.48</i>
CENTURYLINK	Metro Animal Shelter	Acct #P-307-111-9950 456M	\$16.83
CENTURYLINK	Metro Animal Shelter	Acct #P-307-234-8116 403M	\$156.10
<i>CENTURYLINK - Total For Metro Animal Shelter</i>			<i>\$172.93</i>
CENTURYLINK	Municipal Court	Acct #P-307-111-9950 456M	\$61.49
<i>CENTURYLINK - Total For Municipal Court</i>			<i>\$61.49</i>
CENTURYLINK	Parks - Parks Maint.	Acct #P-307-111-9950 456M	\$61.49

<i>CENTURYLINK - Total For Parks - Parks Maint.</i>			<i>\$61.49</i>
CENTURYLINK	Police Administration	Acct #P-307-111-9950 456M	\$346.42
CENTURYLINK	Police Administration	Acct #P-307-111-5103 060M	\$399.96
<i>CENTURYLINK - Total For Police Administration</i>			<i>\$746.38</i>
CENTURYLINK	Public Safety Communication	Acct #P-307-111-9950 456M	\$11.16
CENTURYLINK	Public Safety Communication	Acct #P-307-111-5107 160M	\$11,129.97
CENTURYLINK	Public Safety Communication	Acct #P-307-632-4759 643M	\$303.75
CENTURYLINK	Public Safety Communication	Acct #307-235-7592 537B	\$217.02
<i>CENTURYLINK - Total For Public Safety Communications</i>			<i>\$11,661.90</i>
CENTURYLINK	Rec Center - Operations	Acct #P-307-111-9950 456M	\$44.66
<i>CENTURYLINK - Total For Rec Center - Operations</i>			<i>\$44.66</i>
CENTURYLINK	Regional Water Operations	Acct #P-307-111-9950 456M	\$22.33
<i>CENTURYLINK - Total For Regional Water Operations</i>			<i>\$22.33</i>
CENTURYLINK	Risk Management	Acct #P-307-111-9950 456M	\$16.86
<i>CENTURYLINK - Total For Risk Management</i>			<i>\$16.86</i>
CENTURYLINK	Sewer Wastewater Collection	Acct #P-307-111-9950 456M	\$11.16
CENTURYLINK	Sewer Wastewater Collection	Acct #307-234-6303 407B remote device dat	\$81.38
<i>CENTURYLINK - Total For Sewer Wastewater Collection</i>			<i>\$92.54</i>
CENTURYLINK	Streets	Acct #P-307-111-9950 456M	\$39.16
<i>CENTURYLINK - Total For Streets</i>			<i>\$39.16</i>
CENTURYLINK	Water Administration	Acct #P-307-111-9950 456M	\$22.33
<i>CENTURYLINK - Total For Water Administration</i>			<i>\$22.33</i>
CENTURYLINK	Water Distribution	Acct #P-307-111-9950 456M	\$16.83
<i>CENTURYLINK - Total For Water Distribution</i>			<i>\$16.83</i>
CENTURYLINK	Water Meters	Acct #P-307-111-9950 456M	\$33.31
<i>CENTURYLINK - Total For Water Meters</i>			<i>\$33.31</i>
CENTURYLINK	WWTP Operations	Acct #P-307-111-9950 456M	\$33.49
CENTURYLINK	WWTP Operations	Acct #P-307-111-5113 619M	\$95.34
<i>CENTURYLINK - Total For WWTP Operations</i>			<i>\$128.83</i>
CENTURYLINK	WWTP Regional Interceptors	Acct #307-472-1129 839B	\$60.57
<i>CENTURYLINK - Total For WWTP Regional Interceptors</i>			<i>\$60.57</i>
CENTURYLINK - ALL DEPARTMENTS			\$14,216.07

CHEAPESTEEES.COM

CHEAPESTEEES.COM	Aquatics- Marion Kreiner Con Lifeguard, Manager, and Cashier Shirts	\$22.00
------------------	---	---------

<i>CHEAPESTEES.COM - Total For Aquatics- Marion Kreiner Conc</i>			<i>\$22.00</i>
CHEAPESTEES.COM	Aquatics- Mike Sedar Conc	Lifeguard, Manager, and Cashier Shirts	\$180.00
<i>CHEAPESTEES.COM - Total For Aquatics- Mike Sedar Conc</i>			<i>\$180.00</i>
CHEAPESTEES.COM	Aquatics- Mike Sedar Oper.	Lifeguard, Manager, and Cashier Shirts	\$27.06
<i>CHEAPESTEES.COM - Total For Aquatics- Mike Sedar Oper.</i>			<i>\$27.06</i>
CHEAPESTEES.COM	Aquatics- Paradise Valley Con	Lifeguard, Manager, and Cashier Shirts	\$154.00
<i>CHEAPESTEES.COM - Total For Aquatics- Paradise Valley Conc</i>			<i>\$154.00</i>
CHEAPESTEES.COM	Aquatics- Paradise Valley Op	Lifeguard, Manager, and Cashier Shirts	\$219.23
<i>CHEAPESTEES.COM - Total For Aquatics- Paradise Valley Oper</i>			<i>\$219.23</i>
CHEAPESTEES.COM	Aquatics- Washington Conc	Lifeguard, Manager, and Cashier Shirts	\$84.00
<i>CHEAPESTEES.COM - Total For Aquatics- Washington Conc</i>			<i>\$84.00</i>
CHEAPESTEES.COM	Aquatics- Washington Oper	Lifeguard, Manager, and Cashier Shirts	\$383.00
<i>CHEAPESTEES.COM - Total For Aquatics- Washington Oper</i>			<i>\$383.00</i>
CHEAPESTEES.COM - ALL DEPARTMENTS			\$1,069.29

CHEYENNE LITTLE AM

CHEYENNE LITTLE AM	Health Insurance Fund	2023 Workforce Summit - Cheyenne	\$9.75
<i>CHEYENNE LITTLE AM - Total For Health Insurance Fund</i>			<i>\$9.75</i>
CHEYENNE LITTLE AM - ALL DEPARTMENTS			\$9.75

CHUG CHUG GAS AND GO

CHUG CHUG GAS AND GO	Customer Service	FUEL FOR VEHICLE DURING LEADERSHIP TRA	\$35.00
<i>CHUG CHUG GAS AND GO - Total For Customer Service</i>			<i>\$35.00</i>
CHUG CHUG GAS AND GO - ALL DEPARTMENTS			\$35.00

CITY OF CASPER

CITY OF CASPER	Parks - Parks Maint.	Passenger Tires - Balefill Ticket #85572	\$3.25
<i>CITY OF CASPER - Total For Parks - Parks Maint.</i>			<i>\$3.25</i>
CITY OF CASPER	Public Transit - Operations	Monthly IT Services	\$3,667.08
<i>CITY OF CASPER - Total For Public Transit - Operations</i>			<i>\$3,667.08</i>
CITY OF CASPER	Refuse - Residential	Garbage baler & recycle cardboard	\$7,280.90
CITY OF CASPER	Refuse - Residential	Garbage baler & recycle newspaper/cardboa	\$10,654.05
CITY OF CASPER	Refuse - Residential	Garbage baler & recycle cardboard	\$7,844.10

CITY OF CASPER	Refuse - Residential	Garbage baler & recycle newspaper/cardboa	\$7,131.85
CITY OF CASPER	Refuse - Residential	Garbage baler & recycle newspaper/cardboa	\$8,936.95
CITY OF CASPER	Refuse - Residential	Garbage baler & recycle cardboard	\$578.05
CITY OF CASPER	Refuse - Residential	Garbage baler & recycle newspaper/cardboa	\$8,595.68
CITY OF CASPER	Refuse - Residential	Garbage baler & recycle cardboard	\$7,782.78
CITY OF CASPER	Refuse - Residential	Garbage baler & recycle cardboard	\$530.75
CITY OF CASPER	Refuse - Residential	Garbage baler & recycle newspaper/cardboa	\$7,871.60
CITY OF CASPER	Refuse - Residential	Garbage baler & recycle cardboard	\$6,711.65
<i>CITY OF CASPER - Total For Refuse - Residential</i>			<i>\$73,918.36</i>
CITY OF CASPER	Regional Water Operations	Sewer & Trash - Sewer & Refuse	\$31.78
CITY OF CASPER	Regional Water Operations	Sewer & Trash - Sewer & Refuse	\$89.00
<i>CITY OF CASPER - Total For Regional Water Operations</i>			<i>\$120.78</i>
CITY OF CASPER	Risk Management	15th & CY-HID #2164 - Claim #2023118	\$562.06
<i>CITY OF CASPER - Total For Risk Management</i>			<i>\$562.06</i>
CITY OF CASPER	WWTP Operations	Sump Sludge/Honey Wagon	\$147.40
CITY OF CASPER	WWTP Operations	Sump Sludge/Honey Wagon	\$116.60
CITY OF CASPER	WWTP Operations	Alternate Daily Compost	\$514.85
CITY OF CASPER	WWTP Operations	Sump Sludge/Honey Wagon	\$88.00
CITY OF CASPER	WWTP Operations	Sump Sludge/Honey Wagon	\$155.65
CITY OF CASPER	WWTP Operations	Sump Sludge/Honey Wagon	\$84.70
<i>CITY OF CASPER - Total For WWTP Operations</i>			<i>\$1,107.20</i>
CITY OF CASPER - ALL DEPARTMENTS			\$79,378.73

CITY SERVICE ELECTRI

CITY SERVICE ELECTRI	Hogadon - Operations	Heater Replacement - labor / materials	\$998.68
<i>CITY SERVICE ELECTRI - Total For Hogadon - Operations</i>			<i>\$998.68</i>
CITY SERVICE ELECTRI - ALL DEPARTMENTS			\$998.68

CIVIL ENGINEERING PR

CIVIL ENGINEERING PR	Balefill - Disposal & Landfill	2023 CRL Survey	\$3,375.00
<i>CIVIL ENGINEERING PR - Total For Balefill - Disposal & Landfill</i>			<i>\$3,375.00</i>
CIVIL ENGINEERING PR - ALL DEPARTMENTS			\$3,375.00

CLEAN CLUB 307

CLEAN CLUB 307	Balefill - Baler Processing	Cleaning / Janitorial Service	\$540.00
<i>CLEAN CLUB 307 - Total For Balefill - Baler Processing</i>			<i>\$540.00</i>
CLEAN CLUB 307	Balefill - Disposal & Landfill	Cleaning / Janitorial Service	\$435.00
<i>CLEAN CLUB 307 - Total For Balefill - Disposal & Landfill</i>			<i>\$435.00</i>
CLEAN CLUB 307 - ALL DEPARTMENTS			\$975.00

CMI TECO, INC.

CMI TECO, INC.	Refuse - Commercial	Coolant hose TRK#2272 RESIDENT SIDELOAD	\$129.87
CMI TECO, INC.	Refuse - Commercial	Equipment repair TRK#2287 COMMERCIAL R	\$2,026.85
CMI TECO, INC.	Refuse - Commercial	Mudflap TRK#2287 COMMERCIAL ROLL OFF	\$7.62
CMI TECO, INC.	Refuse - Commercial	Door Hinges TRK#2288 COMMERCIAL FL 201	\$939.54
<i>CMI TECO, INC. - Total For Refuse - Commercial</i>			<i>\$3,103.88</i>
CMI TECO, INC.	Refuse - Residential	Equipment repair TRK#2285 RESIDENT SIDEL	\$115.00
CMI TECO, INC.	Refuse - Residential	Equipment repair TRK#2285 RESIDENT SIDEL	\$1,011.66
CMI TECO, INC.	Refuse - Residential	Rubber belts TRK#2312 RESIDENT SIDELOAD	\$292.62
CMI TECO, INC.	Refuse - Residential	Air valve TRK#2275 RESIDENT SIDELOAD 201	\$419.15
CMI TECO, INC.	Refuse - Residential	Equipment repair Trk#2284 Resident Sideloa	\$6,425.63
CMI TECO, INC.	Refuse - Residential	Engine oil & grease TRK#2284 RESIDENT SID	\$228.20
<i>CMI TECO, INC. - Total For Refuse - Residential</i>			<i>\$8,492.26</i>
CMI TECO, INC. - ALL DEPARTMENTS			\$11,596.14

COBBLESTONE INN

COBBLESTONE INN	Police Career Services	LODGING, HOTELS, MOTELS, RESORTS Chand	(\$310.52)
<i>COBBLESTONE INN - Total For Police Career Services</i>			<i>(\$310.52)</i>
COBBLESTONE INN - ALL DEPARTMENTS			(\$310.52)

COCA COLA BOTTLING C

COCA COLA BOTTLING C	Balefill - Disposal & Landfill	Water delivery for scale house customers	\$24.75
<i>COCA COLA BOTTLING C - Total For Balefill - Disposal & Landfill</i>			<i>\$24.75</i>
COCA COLA BOTTLING C - ALL DEPARTMENTS			\$24.75

COMMUNICATION TECHNO

COMMUNICATION TECHNO	Capital Projects Fund	Installation of APX7500	\$3,000.00
COMMUNICATION TECHNO	Capital Projects Fund	Removal of components for re-store / use	\$880.00
<i>COMMUNICATION TECHNO - Total For Capital Projects Fund</i>			<i>\$3,880.00</i>
COMMUNICATION TECHNO	Police Administration	Changed gun lock from Proguard to handcuff	\$334.00
COMMUNICATION TECHNO	Police Administration	Battery bypassed, secondary battery remove	\$110.00
COMMUNICATION TECHNO	Police Administration	Bad battery, removed aux battery	\$110.00
<i>COMMUNICATION TECHNO - Total For Police Administration</i>			<i>\$554.00</i>
COMMUNICATION TECHNO - ALL DEPARTMENTS			\$4,434.00

COMPRESSION LEASING

COMPRESSION LEASING	WWTP Operations	Filters	\$681.86
<i>COMPRESSION LEASING - Total For WWTP Operations</i>			<i>\$681.86</i>
COMPRESSION LEASING - ALL DEPARTMENTS			\$681.86

CONOCO - STOP-N-GO

CONOCO - STOP-N-GO	Fire-EMS Operations	SERVICE STATIONS	\$63.89
<i>CONOCO - STOP-N-GO - Total For Fire-EMS Operations</i>			<i>\$63.89</i>
CONOCO - STOP-N-GO - ALL DEPARTMENTS			\$63.89

CONVERGEONE

CONVERGEONE	City Manager	Cisco desk phone	\$187.24
<i>CONVERGEONE - Total For City Manager</i>			<i>\$187.24</i>
CONVERGEONE	Information Services	Duo MFA Licenses	\$3,780.00
<i>CONVERGEONE - Total For Information Services</i>			<i>\$3,780.00</i>
CONVERGEONE	Police Administration	Duo MFA Licenses	\$3,996.00
<i>CONVERGEONE - Total For Police Administration</i>			<i>\$3,996.00</i>
CONVERGEONE - ALL DEPARTMENTS			\$7,963.24

CONVERGEONE INC

CONVERGEONE INC	WWTP Regional Interceptors	Firewalls	\$1,720.80
<i>CONVERGEONE INC - Total For WWTP Regional Interceptors</i>			<i>\$1,720.80</i>

CONVERGEONE INC - ALL DEPARTMENTS

\$1,720.80

Core & Main

Core & Main	Water Meters	SEAL PINS	\$19.00
-------------	--------------	-----------	---------

<i>Core & Main - Total For Water Meters</i>			\$19.00
---	--	--	---------

Core & Main - ALL DEPARTMENTS

\$19.00

COWBOY SUPPLY HOUSE

COWBOY SUPPLY HOUSE	Buildings & Structures Fund	Paper towels	\$210.39
---------------------	-----------------------------	--------------	----------

COWBOY SUPPLY HOUSE	Buildings & Structures Fund	Restroom Cleaner & Latex Gloves	\$223.42
---------------------	-----------------------------	---------------------------------	----------

COWBOY SUPPLY HOUSE	Buildings & Structures Fund	CRC cleaning supplies; bath & body; liquid gu	\$240.03
---------------------	-----------------------------	---	----------

COWBOY SUPPLY HOUSE	Buildings & Structures Fund	Trash liners	\$52.99
---------------------	-----------------------------	--------------	---------

<i>COWBOY SUPPLY HOUSE - Total For Buildings & Structures Fund</i>			\$726.83
--	--	--	----------

COWBOY SUPPLY HOUSE	Rec Center - Operations	CRC cleaning supplies; bath & body; liquid gu	\$263.75
---------------------	-------------------------	---	----------

COWBOY SUPPLY HOUSE	Rec Center - Operations	CRC ICE Melt-15 bags/50 lbs each	\$206.25
---------------------	-------------------------	----------------------------------	----------

<i>COWBOY SUPPLY HOUSE - Total For Rec Center - Operations</i>			\$470.00
--	--	--	----------

COWBOY SUPPLY HOUSE - ALL DEPARTMENTS

\$1,196.83

CPS DISTRIBUTORS, IN

CPS DISTRIBUTORS, IN	Balefill - Disposal & Landfill	IRRIGATION SUPPLIES FOR LANDSCAPING PR	\$101.89
----------------------	--------------------------------	--	----------

CPS DISTRIBUTORS, IN	Balefill - Disposal & Landfill	IRRIGATION SUPPLIES FOR LANDSCAPING PR	\$212.71
----------------------	--------------------------------	--	----------

<i>CPS DISTRIBUTORS, IN - Total For Balefill - Disposal & Landfill</i>			\$314.60
--	--	--	----------

CPS DISTRIBUTORS, IN - ALL DEPARTMENTS

\$314.60

CPU IIT

CPU IIT	Balefill - Disposal & Landfill	Monitors and docking station for computer	\$648.00
---------	--------------------------------	---	----------

<i>CPU IIT - Total For Balefill - Disposal & Landfill</i>			\$648.00
---	--	--	----------

CPU IIT	Information Services	Meeting Owl with Expansion Mic, Jabra Spea	\$1,375.00
---------	----------------------	--	------------

<i>CPU IIT - Total For Information Services</i>			\$1,375.00
---	--	--	------------

CPU IIT - ALL DEPARTMENTS

\$2,023.00

CREATOPY

CREATOPY	City Manager	Creatopy Dues and Subscriptions	\$32.00
<i>CREATOPY - Total For City Manager</i>			<i>\$32.00</i>
CREATOPY - ALL DEPARTMENTS			\$32.00

CRESCENT ELECTRIC SU

CRESCENT ELECTRIC SU	Buildings & Structures Fund	OSHA Inspection repair supplies for Maratho	\$192.27
<i>CRESCENT ELECTRIC SU - Total For Buildings & Structures Fund</i>			<i>\$192.27</i>
CRESCENT ELECTRIC SU	Regional Water Operations	Spare Motor Savers for Well Houses - Pump	\$340.10
<i>CRESCENT ELECTRIC SU - Total For Regional Water Operations</i>			<i>\$340.10</i>
CRESCENT ELECTRIC SU - ALL DEPARTMENTS			\$532.37

CRIME SCENE INFORMAT

CRIME SCENE INFORMAT	Police Administration	Basic Program & Web Tips - May 2023	\$122.00
<i>CRIME SCENE INFORMAT - Total For Police Administration</i>			<i>\$122.00</i>
CRIME SCENE INFORMAT - ALL DEPARTMENTS			\$122.00

CROWN CONSTRUCTION L

CROWN CONSTRUCTION L	Balefill - Disposal & Landfill	Installation of Leachate Force	\$68,729.04
<i>CROWN CONSTRUCTION L - Total For Balefill - Disposal & Landfill</i>			<i>\$68,729.04</i>
CROWN CONSTRUCTION L	River Riparian & Upland Area	NPRR 1st Street Reach Boat Ram	\$33,250.00
CROWN CONSTRUCTION L	River Riparian & Upland Area	NPRR 1st Street Reach Boat Ram	\$170,116.50
<i>CROWN CONSTRUCTION L - Total For River Riparian & Upland Areas</i>			<i>\$203,366.50</i>
CROWN CONSTRUCTION L	Streets	Snow removal	\$4,500.00
<i>CROWN CONSTRUCTION L - Total For Streets</i>			<i>\$4,500.00</i>
CROWN CONSTRUCTION L - ALL DEPARTMENTS			\$276,595.54

CRUM ELECTRIC SUPPLY

CRUM ELECTRIC SUPPLY	Water Tanks	REPLACING LIGHTS IN BOOSTERS- OTHER M	\$14.67
CRUM ELECTRIC SUPPLY	Water Tanks	Credit- Other Materials & Supplies	(\$42.28)
CRUM ELECTRIC SUPPLY	Water Tanks	RAB- OTHER MATERIALS & SUPPLIES	\$185.28
<i>CRUM ELECTRIC SUPPLY - Total For Water Tanks</i>			<i>\$157.67</i>
CRUM ELECTRIC SUPPLY	WWTP Operations	ELECTRICAL PARTS	\$57.17
<i>CRUM ELECTRIC SUPPLY - Total For WWTP Operations</i>			<i>\$57.17</i>

CRUM ELECTRIC SUPPLY - ALL DEPARTMENTS \$214.84

DANA KEPNER CO. OF W

DANA KEPNER CO. OF W Risk Management Fire hydrant \$5,500.00

DANA KEPNER CO. OF W Risk Management Fire hydrant \$5,500.00

DANA KEPNER CO. OF W - Total For Risk Management \$11,000.00

DANA KEPNER CO. OF W - ALL DEPARTMENTS \$11,000.00

DANA KEPNER COMPANY

DANA KEPNER COMPANY Water Distribution SS CURB BOX ROD- WATER & SEWER LINE M \$255.00

DANA KEPNER COMPANY - Total For Water Distribution \$255.00

DANA KEPNER COMPANY - ALL DEPARTMENTS \$255.00

DELL MARKETING LP

DELL MARKETING LP Information Services VLA SHRD SVR/ENTERPRISE/OFFICE 365/SUB \$12,440.91

DELL MARKETING LP - Total For Information Services \$12,440.91

DELL MARKETING LP Police Administration COMPUTERS,COMPUTER PERIPHERAL EQUIP \$250.94

DELL MARKETING LP - Total For Police Administration \$250.94

DELL MARKETING LP - ALL DEPARTMENTS \$12,691.85

DENNIS SUPPLY CO.

DENNIS SUPPLY CO. Buildings & Structures Fund HVAC PM Supplies for Hogadon - Dennis Sup \$44.55

DENNIS SUPPLY CO. Buildings & Structures Fund HVAC Repair for Water Garage - Dennis Supp \$191.11

DENNIS SUPPLY CO. Buildings & Structures Fund HVAC Repair supplies for Fire Station 6 - Den \$177.40

DENNIS SUPPLY CO. Buildings & Structures Fund Spring HVAC PM Supplies - Dennis Supply \$30.24

DENNIS SUPPLY CO. - Total For Buildings & Structures Fund \$443.30

DENNIS SUPPLY CO. - ALL DEPARTMENTS \$443.30

DENVER INDUSTRIAL SA

DENVER INDUSTRIAL SA Streets Concrete Patch & Shipping/Handling \$2,155.67

DENVER INDUSTRIAL SA - Total For Streets \$2,155.67

DENVER INDUSTRIAL SA - ALL DEPARTMENTS

\$2,155.67

DESERT MTN. CORP.

DESERT MTN. CORP.	Streets	Ice Slicer for 2023	\$3,949.46
DESERT MTN. CORP.	Streets	Ice Slicer for 2023	\$4,117.55
DESERT MTN. CORP.	Streets	Ice Slicer for 2023	\$3,269.43
DESERT MTN. CORP.	Streets	Ice Slicer for 2023	\$3,459.48
DESERT MTN. CORP.	Streets	Ice Slicer for 2023	\$3,450.70
DESERT MTN. CORP.	Streets	Ice Slicer for 2023	\$3,467.18
DESERT MTN. CORP.	Streets	Ice Slicer for 2023	\$3,432.03

DESERT MTN. CORP. - Total For Streets

\$25,145.83

DESERT MTN. CORP. - ALL DEPARTMENTS

\$25,145.83

DIAMOND VOGEL PAINTS

DIAMOND VOGEL PAINTS	Buildings & Structures Fund	Pool paint for PV Pool - Diamond Vogel	\$3,553.56
----------------------	-----------------------------	--	------------

DIAMOND VOGEL PAINTS - Total For Buildings & Structures Fund

\$3,553.56

DIAMOND VOGEL PAINTS - ALL DEPARTMENTS

\$3,553.56

DONS MOBILE CARPET I

DONS MOBILE CARPET I	Ft. Caspar Museum	Carpet Installation - labor / materials	\$4,297.13
----------------------	-------------------	---	------------

DONS MOBILE CARPET I - Total For Ft. Caspar Museum

\$4,297.13

DONS MOBILE CARPET I - ALL DEPARTMENTS

\$4,297.13

DYNAMIC CONTROLS INC

DYNAMIC CONTROLS INC	Public Safety Communication	Door repair	\$62.50
----------------------	-----------------------------	-------------	---------

DYNAMIC CONTROLS INC - Total For Public Safety Communications

\$62.50

DYNAMIC CONTROLS INC - ALL DEPARTMENTS

\$62.50

ECONOMIC DEVELOPMENT

ECONOMIC DEVELOPMENT	Social Community Services	4th Qtr FY2023 Administrative & Incentive F	\$110,430.00
----------------------	---------------------------	---	--------------

ECONOMIC DEVELOPMENT - Total For Social Community Services

\$110,430.00

ECONOMIC DEVELOPMENT - ALL DEPARTMENTS

\$110,430.00

ELEVATORKEYS DOTCOM

ELEVATORKEYS DOTCOM	Buildings & Structures Fund	Elevator Keys for Ash St Bldg - Elevatorkeys.c	\$29.73
---------------------	-----------------------------	--	---------

<i>ELEVATORKEYS DOTCOM - Total For Buildings & Structures Fund</i>			\$29.73
--	--	--	---------

ELEVATORKEYS DOTCOM - ALL DEPARTMENTS

\$29.73

EMERGENCY MEDICAL PH

EMERGENCY MEDICAL PH	Fire-EMS Administration	Medical Direction for Casper F	\$700.00
----------------------	-------------------------	--------------------------------	----------

<i>EMERGENCY MEDICAL PH - Total For Fire-EMS Administration</i>			\$700.00
---	--	--	----------

EMERGENCY MEDICAL PH - ALL DEPARTMENTS

\$700.00

EMPLOYEE REIMBURSEME

EMPLOYEE REIMBURSEME	Parks - Parks Maint.	Work Boot Reimbursement	\$150.00
----------------------	----------------------	-------------------------	----------

<i>EMPLOYEE REIMBURSEME - Total For Parks - Parks Maint.</i>			\$150.00
--	--	--	----------

EMPLOYEE REIMBURSEME	Police Career Services	Work Clothing Reimbursement	\$266.61
----------------------	------------------------	-----------------------------	----------

<i>EMPLOYEE REIMBURSEME - Total For Police Career Services</i>			\$266.61
--	--	--	----------

EMPLOYEE REIMBURSEME	Water Distribution	Distribution Systms Level 2 Exam Reimburse	\$100.00
----------------------	--------------------	--	----------

<i>EMPLOYEE REIMBURSEME - Total For Water Distribution</i>			\$100.00
--	--	--	----------

EMPLOYEE REIMBURSEME - ALL DEPARTMENTS

\$516.61

ENERGY LABORATORIES

ENERGY LABORATORIES	Regional Water Operations	Analysis Parameter - Testing	\$339.00
---------------------	---------------------------	------------------------------	----------

<i>ENERGY LABORATORIES - Total For Regional Water Operations</i>			\$339.00
--	--	--	----------

ENERGY LABORATORIES - ALL DEPARTMENTS

\$339.00

ENERGY LABRATORIES I

ENERGY LABRATORIES I	Regional Water Operations	Bacteria, Public Water Supply Tests- Testing	\$53.00
----------------------	---------------------------	--	---------

ENERGY LABRATORIES I	Regional Water Operations	Aerobic Endospores Testing - Testing	\$339.00
----------------------	---------------------------	--------------------------------------	----------

ENERGY LABRATORIES I	Regional Water Operations	Analysis Parameter - Total Metals - Testing	\$53.00
----------------------	---------------------------	---	---------

<i>ENERGY LABRATORIES I - Total For Regional Water Operations</i>			\$445.00
---	--	--	----------

ENERGY LABRATORIES I	Water Tanks	Bacteria, Public Water Supply testing	\$561.00
----------------------	-------------	---------------------------------------	----------

ENERGY LABRATORIES I	Water Tanks	Bacteria, SDWA testing	\$53.00
ENERGY LABRATORIES I	Water Tanks	Bacteria, Public Water Supply testing	\$495.00
<i>ENERGY LABRATORIES I - Total For Water Tanks</i>			<i>\$1,109.00</i>
ENERGY LABRATORIES I - ALL DEPARTMENTS			\$1,554.00

EQUALIZED PRODUCTION

EQUALIZED PRODUCTION	Capital Projects Fund	New building or building modif	\$78,672.71
<i>EQUALIZED PRODUCTION - Total For Capital Projects Fund</i>			<i>\$78,672.71</i>
EQUALIZED PRODUCTION - ALL DEPARTMENTS			\$78,672.71

FACEBK DZTPQMTU72

FACEBK DZTPQMTU72	Ft. Caspar Museum	Facebook Advertising	\$20.00
<i>FACEBK DZTPQMTU72 - Total For Ft. Caspar Museum</i>			<i>\$20.00</i>
FACEBK DZTPQMTU72 - ALL DEPARTMENTS			\$20.00

FACEBK G8EJBK32B2

FACEBK G8EJBK32B2	Refuse - Residential	Rear Loader off throughout February	\$129.79
<i>FACEBK G8EJBK32B2 - Total For Refuse - Residential</i>			<i>\$129.79</i>
FACEBK G8EJBK32B2 - ALL DEPARTMENTS			\$129.79

FAIRFIELD INN LOVELA

FAIRFIELD INN LOVELA	Customer Service	LEADERSHIP TRAINING HOTEL - FAIRFIELD IN	\$59.79
<i>FAIRFIELD INN LOVELA - Total For Customer Service</i>			<i>\$59.79</i>
FAIRFIELD INN LOVELA	Finance	LEADERSHIP TRAINING HOTEL - FAIRFIELD IN	\$59.78
<i>FAIRFIELD INN LOVELA - Total For Finance</i>			<i>\$59.78</i>
FAIRFIELD INN LOVELA	Municipal Court	LEADERSHIP TRAINING HOTEL - FAIRFIELD IN	\$59.78
<i>FAIRFIELD INN LOVELA - Total For Municipal Court</i>			<i>\$59.78</i>
FAIRFIELD INN LOVELA	Risk Management	LEADERSHIP TRAINING HOTEL - FAIRFIELD IN	\$59.79
<i>FAIRFIELD INN LOVELA - Total For Risk Management</i>			<i>\$59.79</i>
FAIRFIELD INN LOVELA - ALL DEPARTMENTS			\$239.14

FEDEX OFFIC942000094

FEDEX OFFIC942000094	Ft. Caspar Museum	Panels for Exhibit	\$186.60
<i>FEDEX OFFIC942000094 - Total For Ft. Caspar Museum</i>			<i>\$186.60</i>
FEDEX OFFIC942000094 - ALL DEPARTMENTS			\$186.60

FERGUSON ENTERPRISES

FERGUSON ENTERPRISES	Regional Water Operations	Plugs & PVC Cement & Parts for Surface Wat	\$121.72
FERGUSON ENTERPRISES	Regional Water Operations	Credit for Over Charge on Previous Transacti	(\$16.68)
FERGUSON ENTERPRISES	Regional Water Operations	Spare Check Valve Rebuild Kit for Sump Pum	\$241.66
<i>FERGUSON ENTERPRISES - Total For Regional Water Operations</i>			<i>\$346.70</i>
FERGUSON ENTERPRISES - ALL DEPARTMENTS			\$346.70

FINDMYSHIFT

FINDMYSHIFT	Hogadon - Operations	Scheduler	\$28.64
<i>FINDMYSHIFT - Total For Hogadon - Operations</i>			<i>\$28.64</i>
FINDMYSHIFT - ALL DEPARTMENTS			\$28.64

FIRST INTERSTATE BAN

FIRST INTERSTATE BAN	Balefill - Disposal & Landfill	Investment Fees - 2/16/23 to 3/15/23	\$886.46
<i>FIRST INTERSTATE BAN - Total For Balefill - Disposal & Landfill</i>			<i>\$886.46</i>
FIRST INTERSTATE BAN	Capital Projects Fund	Investment Fees - 2/16/23 to 3/15/23	\$4,007.35
<i>FIRST INTERSTATE BAN - Total For Capital Projects Fund</i>			<i>\$4,007.35</i>
FIRST INTERSTATE BAN	Community Development	Duplicate Deposit Slips	\$38.66
<i>FIRST INTERSTATE BAN - Total For Community Development</i>			<i>\$38.66</i>
FIRST INTERSTATE BAN	Customer Service	Duplicate Deposit Slips	\$135.46
<i>FIRST INTERSTATE BAN - Total For Customer Service</i>			<i>\$135.46</i>
FIRST INTERSTATE BAN	Engineering	Duplicate Deposit Slips	\$19.33
<i>FIRST INTERSTATE BAN - Total For Engineering</i>			<i>\$19.33</i>
FIRST INTERSTATE BAN	General Fund Revenue	Investment Fees - 2/16/23 to 3/15/23	\$3,548.61
<i>FIRST INTERSTATE BAN - Total For General Fund Revenue</i>			<i>\$3,548.61</i>
FIRST INTERSTATE BAN	Health Insurance Fund	Gift cards	\$1,642.00
FIRST INTERSTATE BAN	Health Insurance Fund	Investment Fees - 2/16/23 to 3/15/23	\$268.29
<i>FIRST INTERSTATE BAN - Total For Health Insurance Fund</i>			<i>\$1,910.29</i>
FIRST INTERSTATE BAN	Ice Arena - Operations	Duplicate Deposit Slips	\$38.66

<i>FIRST INTERSTATE BAN - Total For Ice Arena - Operations</i>		\$38.66
FIRST INTERSTATE BAN	Local Assessment District Fun Investment Fees - 2/16/23 to 3/15/23	\$444.38
<i>FIRST INTERSTATE BAN - Total For Local Assessment District Fund</i>		\$444.38
FIRST INTERSTATE BAN	Metro Animal Shelter Investment Fees - 2/16/23 to 3/15/23	\$43.39
<i>FIRST INTERSTATE BAN - Total For Metro Animal Shelter</i>		\$43.39
FIRST INTERSTATE BAN	Municipal Court Duplicate Deposit Slips	\$38.66
<i>FIRST INTERSTATE BAN - Total For Municipal Court</i>		\$38.66
FIRST INTERSTATE BAN	Opportunities Fund Investment Fees - 2/16/23 to 3/15/23	\$234.49
<i>FIRST INTERSTATE BAN - Total For Opportunities Fund</i>		\$234.49
FIRST INTERSTATE BAN	Parking Fund Investment Fees - 2/16/23 to 3/15/23	\$10.84
<i>FIRST INTERSTATE BAN - Total For Parking Fund</i>		\$10.84
FIRST INTERSTATE BAN	Perpetual Care Operations Investment Fees - 2/16/23 to 3/15/23	\$2,380.78
<i>FIRST INTERSTATE BAN - Total For Perpetual Care Operations</i>		\$2,380.78
FIRST INTERSTATE BAN	Police Administration Duplicate Deposit Slips	\$38.66
<i>FIRST INTERSTATE BAN - Total For Police Administration</i>		\$38.66
FIRST INTERSTATE BAN	Public Transit - CARES Act Duplicate Deposit Slips	\$96.65
<i>FIRST INTERSTATE BAN - Total For Public Transit - CARES Act</i>		\$96.65
FIRST INTERSTATE BAN	Rec Center - Admin Duplicate Deposit Slips	\$38.66
<i>FIRST INTERSTATE BAN - Total For Rec Center - Admin</i>		\$38.66
FIRST INTERSTATE BAN	Refuse - Residential Duplicate Deposit Slips	\$38.66
FIRST INTERSTATE BAN	Refuse - Residential Investment Fees - 2/16/23 to 3/15/23	\$253.58
<i>FIRST INTERSTATE BAN - Total For Refuse - Residential</i>		\$292.24
FIRST INTERSTATE BAN	Revolving Land Fund Investment Fees - 2/16/23 to 3/15/23	\$56.70
<i>FIRST INTERSTATE BAN - Total For Revolving Land Fund</i>		\$56.70
FIRST INTERSTATE BAN	River Fund Investment Fees - 2/16/23 to 3/15/23	\$88.16
<i>FIRST INTERSTATE BAN - Total For River Fund</i>		\$88.16
FIRST INTERSTATE BAN	Sewer Administration Investment Fees - 2/16/23 to 3/15/23	\$490.15
<i>FIRST INTERSTATE BAN - Total For Sewer Administration</i>		\$490.15
FIRST INTERSTATE BAN	Water Administration Investment Fees - 2/16/23 to 3/15/23	\$1,576.25
<i>FIRST INTERSTATE BAN - Total For Water Administration</i>		\$1,576.25
FIRST INTERSTATE BAN	Weed & Pest Fund Investment Fees - 2/16/23 to 3/15/23	\$62.92
<i>FIRST INTERSTATE BAN - Total For Weed & Pest Fund</i>		\$62.92
FIRST INTERSTATE BAN	WWTP Operations Investment Fees - 2/16/23 to 3/15/23	\$694.62
<i>FIRST INTERSTATE BAN - Total For WWTP Operations</i>		\$694.62
FIRST INTERSTATE BAN - ALL DEPARTMENTS		\$17,172.37

FIRST VETERINARY SUP

FIRST VETERINARY SUP	Metro Animal Shelter	Veterinary supplies	\$139.14
FIRST VETERINARY SUP	Metro Animal Shelter	Veterinary supplies	\$135.60
FIRST VETERINARY SUP	Metro Animal Shelter	Veterinary supplies	\$1,216.72

FIRST VETERINARY SUP - Total For Metro Animal Shelter \$1,491.46

FIRST VETERINARY SUP - ALL DEPARTMENTS \$1,491.46

FORMS FULFILLMENT CE

FORMS FULFILLMENT CE	Finance	A/P Check Stock	\$216.56
----------------------	---------	-----------------	----------

FORMS FULFILLMENT CE - Total For Finance \$216.56

FORMS FULFILLMENT CE - ALL DEPARTMENTS \$216.56

GALLES GREENHOUSE AN

GALLES GREENHOUSE AN	Parks - Urban Forestry	tree fertilizer	\$11.99
----------------------	------------------------	-----------------	---------

GALLES GREENHOUSE AN - Total For Parks - Urban Forestry \$11.99

GALLES GREENHOUSE AN - ALL DEPARTMENTS \$11.99

GALLS, INC.

GALLS, INC.	Police Career Services	Uniform supplies	\$27.00
GALLS, INC.	Police Career Services	Uniform supplies	\$577.28
GALLS, INC.	Police Career Services	Uniform supplies	\$85.86
GALLS, INC.	Police Career Services	Uniform supplies	\$170.96
GALLS, INC.	Police Career Services	Uniform supplies	\$161.96
GALLS, INC.	Police Career Services	Uniform supplies	\$259.20
GALLS, INC.	Police Career Services	Uniform supplies	\$144.32
GALLS, INC.	Police Career Services	Uniform supplies	\$105.42
GALLS, INC.	Police Career Services	Uniform supplies	\$42.93

GALLS, INC. - Total For Police Career Services \$1,574.93

GALLS, INC. - ALL DEPARTMENTS \$1,574.93

GLOBAL SPECTRUM L.P.

GLOBAL SPECTRUM L.P.	Ford Wyoming Center	Net Loss Funds - April 2023	\$75,000.00
----------------------	---------------------	-----------------------------	-------------

GLOBAL SPECTRUM L.P. - Total For Ford Wyoming Center \$75,000.00

GLOBAL SPECTRUM L.P. - ALL DEPARTMENTS \$75,000.00

GO LAW ENFORCEMENT L

GO LAW ENFORCEMENT L Police Career Services POLICE OFFICER RECRUITING - 1 YEAR \$280.00

GO LAW ENFORCEMENT L - Total For Police Career Services \$280.00

GO LAW ENFORCEMENT L - ALL DEPARTMENTS \$280.00

GOOD TO GO STORES

GOOD TO GO STORES Fire-EMS Operations Fuel \$49.78

GOOD TO GO STORES Fire-EMS Operations Fuel for travel \$42.70

GOOD TO GO STORES Fire-EMS Operations Fuel \$36.26

GOOD TO GO STORES Fire-EMS Operations Fuel \$69.42

GOOD TO GO STORES Fire-EMS Operations Fuel \$106.89

GOOD TO GO STORES Fire-EMS Operations AUTOMATED FUEL DISPENSERS \$36.82

GOOD TO GO STORES - Total For Fire-EMS Operations \$341.87

GOOD TO GO STORES - ALL DEPARTMENTS \$341.87

GRAINGER, INC.

GRAINGER, INC. Balefill - Disposal & Landfill OSHA FIXES/SUPPLIES \$420.70

GRAINGER, INC. - Total For Balefill - Disposal & Landfill \$420.70

GRAINGER, INC. Buildings & Structures Fund OSHA Repairs for Marathong - Grainger \$14.47

GRAINGER, INC. - Total For Buildings & Structures Fund \$14.47

GRAINGER, INC. Refuse - Commercial TIRE CHAIN REPAIR TOOL TRUCK BARN \$75.83

GRAINGER, INC. - Total For Refuse - Commercial \$75.83

GRAINGER, INC. Regional Water Operations Ozone Compressor Motors - Machinery Sup \$813.64

GRAINGER, INC. - Total For Regional Water Operations \$813.64

GRAINGER, INC. Sewer Wastewater Collection panel lamp replacements \$359.28

GRAINGER, INC. - Total For Sewer Wastewater Collection \$359.28

GRAINGER, INC. Water Distribution BENCH GRINDER INVENTORY BUILDING- BUI \$16.86

GRAINGER, INC. - Total For Water Distribution \$16.86

GRAINGER, INC. WWTP Regional Interceptors Thermal overload \$114.00

GRAINGER, INC. - Total For WWTP Regional Interceptors \$114.00

GRAINGER, INC. - ALL DEPARTMENTS \$1,814.78

GREAT HARVEST BREAD

GREAT HARVEST BREAD	Community Development	BAKERIES	\$221.82
<i>GREAT HARVEST BREAD - Total For Community Development</i>			\$221.82
GREAT HARVEST BREAD	Human Resources	8 Doughnuts for Celebration with Carter Eve	\$9.88
<i>GREAT HARVEST BREAD - Total For Human Resources</i>			\$9.88
GREAT HARVEST BREAD - ALL DEPARTMENTS			\$231.70

GREINER MOTOR CO - C

GREINER MOTOR CO - C	Capital Projects Fund	Ford Ranger	\$35,062.00
GREINER MOTOR CO - C	Capital Projects Fund	5 marked units	\$45,984.00
GREINER MOTOR CO - C	Capital Projects Fund	5 marked units	\$45,984.00
<i>GREINER MOTOR CO - C - Total For Capital Projects Fund</i>			\$127,030.00
GREINER MOTOR CO - C	Fleet Maintenance Fund	Vehicle repair	\$20,171.23
<i>GREINER MOTOR CO - C - Total For Fleet Maintenance Fund</i>			\$20,171.23
GREINER MOTOR CO - C - ALL DEPARTMENTS			\$147,201.23

GRIZZLY EXCAVATING &

GRIZZLY EXCAVATING &	Streets	Snow removal	\$4,350.00
<i>GRIZZLY EXCAVATING & - Total For Streets</i>			\$4,350.00
GRIZZLY EXCAVATING & - ALL DEPARTMENTS			\$4,350.00

HACH CO., CORP.

HACH CO., CORP.	Regional Water Operations	Sension 9660C Combination Calcium - Lab Su	\$1,005.76
HACH CO., CORP.	Regional Water Operations	DPD TOT Chlorine PP - Lab Supplies	\$685.95
HACH CO., CORP.	Regional Water Operations	Legacy Adapter - Lab Supplies	\$260.96
<i>HACH CO., CORP. - Total For Regional Water Operations</i>			\$1,952.67
HACH CO., CORP.	Water Tanks	SODIUM, POTASSIUM, SULFAMIC- OTHER M	\$110.64
HACH CO., CORP.	Water Tanks	DPD REFILL VIAL- OTHER MATERIALS & SUPP	\$498.29
<i>HACH CO., CORP. - Total For Water Tanks</i>			\$608.93
HACH CO., CORP. - ALL DEPARTMENTS			\$2,561.60

HAJOCA KEENAN SUPP

HAJOCA KEENAN SUPP	WWTP Operations	Plumbing parts	\$4,894.78
<i>HAJOCA KEENAN SUPP - Total For WWTP Operations</i>			<i>\$4,894.78</i>
HAJOCA KEENAN SUPP - ALL DEPARTMENTS			\$4,894.78

HALL'S CUSTOM PAVING

HALL'S CUSTOM PAVING	Public Transit - Operations	Transit Facility Parking Impro	\$78,185.00
<i>HALL'S CUSTOM PAVING - Total For Public Transit - Operations</i>			<i>\$78,185.00</i>
HALL'S CUSTOM PAVING - ALL DEPARTMENTS			\$78,185.00

HARDROCK FOOD

HARDROCK FOOD	Health Insurance Fund	WORKHUMAN CONFERENCE - MEALS	\$42.89
<i>HARDROCK FOOD - Total For Health Insurance Fund</i>			<i>\$42.89</i>
HARDROCK FOOD - ALL DEPARTMENTS			\$42.89

HARDWARE PARTNERS LL

HARDWARE PARTNERS LL	Parks - Special Areas	hedge trimmer	\$589.99
<i>HARDWARE PARTNERS LL - Total For Parks - Special Areas</i>			<i>\$589.99</i>
HARDWARE PARTNERS LL	Weed & Pest Fund	Weed abatement tools	\$455.96
HARDWARE PARTNERS LL	Weed & Pest Fund	supplies	\$71.57
HARDWARE PARTNERS LL	Weed & Pest Fund	tubing	\$10.18
<i>HARDWARE PARTNERS LL - Total For Weed & Pest Fund</i>			<i>\$537.71</i>
HARDWARE PARTNERS LL - ALL DEPARTMENTS			\$1,127.70

HCM LEVELWEAR INC

HCM LEVELWEAR INC	Golf	Merchandise/ Inventory	\$800.31
<i>HCM LEVELWEAR INC - Total For Golf</i>			<i>\$800.31</i>
HCM LEVELWEAR INC - ALL DEPARTMENTS			\$800.31

HENSLEY BATTERY CASP

HENSLEY BATTERY CASP	Traffic Control	2nd & Landmark UPS battery replacement	\$881.08
----------------------	-----------------	--	----------

HENSLEY BATTERY CASP - Total For Traffic Control \$881.08

HENSLEY BATTERY CASP - ALL DEPARTMENTS \$881.08

HLP, INC.

HLP, INC. Metro Animal Shelter Software Annual Support & Maintenance \$2,880.00

HLP, INC. - Total For Metro Animal Shelter \$2,880.00

HLP, INC. - ALL DEPARTMENTS \$2,880.00

HOBBY-LOBBY #0233

HOBBY-LOBBY #0233 Balefill - Disposal & Landfill Office Supplies \$5.88

HOBBY-LOBBY #0233 Balefill - Disposal & Landfill OFFICE SUPPLIES \$2,168.14

HOBBY-LOBBY #0233 - Total For Balefill - Disposal & Landfill \$2,174.02

HOBBY-LOBBY #0233 - ALL DEPARTMENTS \$2,174.02

HOLIDAY INN - RIVERT

HOLIDAY INN - RIVERT Fire-EMS Training Hotel stay while traveling \$98.00

HOLIDAY INN - RIVERT - Total For Fire-EMS Training \$98.00

HOLIDAY INN - RIVERT - ALL DEPARTMENTS \$98.00

HOLLAND & HART LLP

HOLLAND & HART LLP Water Tanks Renegotiation of Water Storage \$27,147.00

HOLLAND & HART LLP Water Tanks Renegotiation of Water Storage \$1,676.00

HOLLAND & HART LLP - Total For Water Tanks \$28,823.00

HOLLAND & HART LLP - ALL DEPARTMENTS \$28,823.00

HOMAX OIL SALES, INC

HOMAX OIL SALES, INC Fleet Maintenance Fund 8004 gal. Clear Diesel - winter blend \$27,229.93

HOMAX OIL SALES, INC Fleet Maintenance Fund Unleaded fuel \$23,764.65

HOMAX OIL SALES, INC - Total For Fleet Maintenance Fund \$50,994.58

HOMAX OIL SALES, INC - ALL DEPARTMENTS \$50,994.58

HONNEN EQUIPMENT CO.

HONNEN EQUIPMENT CO.	WWTP Operations	Switch	\$57.61
<i>HONNEN EQUIPMENT CO. - Total For WWTP Operations</i>			<i>\$57.61</i>
HONNEN EQUIPMENT CO. - ALL DEPARTMENTS			\$57.61

HOSE & RUBBER SUPPLY

HOSE & RUBBER SUPPLY	Balefill - Diversion & Special	Hose 100' Red String for Wood Chip Colorize	\$16.17
HOSE & RUBBER SUPPLY	Balefill - Diversion & Special	Grease Gun Couplers for grease gun compos	\$72.00
<i>HOSE & RUBBER SUPPLY - Total For Balefill - Diversion & Special</i>			<i>\$88.17</i>
HOSE & RUBBER SUPPLY - ALL DEPARTMENTS			\$88.17

HOSE AND RUBBER SUPP

HOSE AND RUBBER SUPP	Water Distribution	PRESSURE WASHER HOSE REPAIR- OTHER M	\$28.88
<i>HOSE AND RUBBER SUPP - Total For Water Distribution</i>			<i>\$28.88</i>
HOSE AND RUBBER SUPP - ALL DEPARTMENTS			\$28.88

HOTSY EQUIPMENT OF W

HOTSY EQUIPMENT OF W	Buildings & Structures Fund	Repair of pressure washer for BAS - Hotsy	\$733.00
<i>HOTSY EQUIPMENT OF W - Total For Buildings & Structures Fund</i>			<i>\$733.00</i>
HOTSY EQUIPMENT OF W - ALL DEPARTMENTS			\$733.00

HQ SOUTHERN BBQ LLC

HQ SOUTHERN BBQ LLC	Risk Management	EATING PLACES, RESTAURANTS	\$1,012.50
<i>HQ SOUTHERN BBQ LLC - Total For Risk Management</i>			<i>\$1,012.50</i>
HQ SOUTHERN BBQ LLC - ALL DEPARTMENTS			\$1,012.50

IAAI

IAAI	Fire-EMS Prevent & Inspect	1 year Membership Dues to IAAI National an	\$123.00
<i>IAAI - Total For Fire-EMS Prevent & Inspect</i>			<i>\$123.00</i>
IAAI - ALL DEPARTMENTS			\$123.00

IACP

IACP	Public Safety Communication	MEMBERSHIP ORGANIZATIONS NOT ELSEW	\$700.00
<i>IACP - Total For Public Safety Communications</i>			<i>\$700.00</i>
IACP - ALL DEPARTMENTS			\$700.00

INDUSTRIAL SCREEN &

INDUSTRIAL SCREEN &	Balefill - Baler Processing	O-RINGS FOR WASTE BALERS	\$25.00
<i>INDUSTRIAL SCREEN & - Total For Balefill - Baler Processing</i>			<i>\$25.00</i>
INDUSTRIAL SCREEN & - ALL DEPARTMENTS			\$25.00

INSITUFORM TECHNOLOG

INSITUFORM TECHNOLOG	Water Revenue and Transfer	Retainage - Contract #22300208	\$6,482.63
<i>INSITUFORM TECHNOLOG - Total For Water Revenue and Transfers</i>			<i>\$6,482.63</i>
INSITUFORM TECHNOLOG	WWTP Operations	N Platte Sanitary Sewer Rehab	\$123,169.98
<i>INSITUFORM TECHNOLOG - Total For WWTP Operations</i>			<i>\$123,169.98</i>
INSITUFORM TECHNOLOG - ALL DEPARTMENTS			\$129,652.61

INTERFAITH OF NATRON

INTERFAITH OF NATRON	Capital Projects Fund	1% #16 Funding Interfaith	\$34,166.77
<i>INTERFAITH OF NATRON - Total For Capital Projects Fund</i>			<i>\$34,166.77</i>
INTERFAITH OF NATRON - ALL DEPARTMENTS			\$34,166.77

INTERMOUNTAIN MOTOR

INTERMOUNTAIN MOTOR	Buildings & Structures Fund	Pump repair supplies for Stuckenhoff - Inter	\$48.53
<i>INTERMOUNTAIN MOTOR - Total For Buildings & Structures Fund</i>			<i>\$48.53</i>
INTERMOUNTAIN MOTOR - ALL DEPARTMENTS			\$48.53

INTERNATIONAL BALER

INTERNATIONAL BALER	Refuse - Recycling	Replace Laser on MRF Baler	\$3,176.42
<i>INTERNATIONAL BALER - Total For Refuse - Recycling</i>			<i>\$3,176.42</i>

INTERNATIONAL BALER - ALL DEPARTMENTS

\$3,176.42

INTERNATIONAL FLUID

INTERNATIONAL FLUID	Balefill - Disposal & Landfill	DOOR VALVES FOR THE BALER	\$2,711.64
---------------------	--------------------------------	---------------------------	------------

<i>INTERNATIONAL FLUID - Total For Balefill - Disposal & Landfill</i>			\$2,711.64
---	--	--	------------

INTERNATIONAL FLUID - ALL DEPARTMENTS

\$2,711.64

INTUIT, INC.

INTUIT, INC.	Balefill - Disposal & Landfill	CLEANING AND MAINTENANCE, JANITORIAL	\$1,102.50
--------------	--------------------------------	--------------------------------------	------------

INTUIT, INC.	Balefill - Disposal & Landfill	CLEANING AND MAINTENANCE, JANITORIAL	\$2,200.00
--------------	--------------------------------	--------------------------------------	------------

<i>INTUIT, INC. - Total For Balefill - Disposal & Landfill</i>			\$3,302.50
--	--	--	------------

INTUIT, INC.	Capital Projects Fund	Relocate Vent in soccer pump house	\$850.00
--------------	-----------------------	------------------------------------	----------

<i>INTUIT, INC. - Total For Capital Projects Fund</i>			\$850.00
---	--	--	----------

INTUIT, INC.	Fire-EMS Operations	Carabiners for search rope on RIT bags for all	\$270.00
--------------	---------------------	--	----------

<i>INTUIT, INC. - Total For Fire-EMS Operations</i>			\$270.00
---	--	--	----------

INTUIT, INC.	Police Administration	MISCELLANEOUS PERSONAL SERVICES Prom	\$513.50
--------------	-----------------------	--------------------------------------	----------

<i>INTUIT, INC. - Total For Police Administration</i>			\$513.50
---	--	--	----------

INTUIT, INC.	Police Career Services	THE BLUE LINE POLICE OFFICER RECRUITING	\$298.00
--------------	------------------------	---	----------

<i>INTUIT, INC. - Total For Police Career Services</i>			\$298.00
--	--	--	----------

INTUIT, INC.	Weed & Pest Fund	Turf Pigment	\$3,150.00
--------------	------------------	--------------	------------

INTUIT, INC.	Weed & Pest Fund	Laser Rock 2 pack and hand helds	\$3,491.61
--------------	------------------	----------------------------------	------------

INTUIT, INC.	Weed & Pest Fund	55 Gallon Wetting agent, Case Maxi Block w	\$2,457.00
--------------	------------------	--	------------

<i>INTUIT, INC. - Total For Weed & Pest Fund</i>			\$9,098.61
--	--	--	------------

INTUIT, INC. - ALL DEPARTMENTS

\$14,332.61

ISA

ISA	Parks - Urban Forestry	ISA Dues	\$187.00
-----	------------------------	----------	----------

<i>ISA - Total For Parks - Urban Forestry</i>			\$187.00
---	--	--	----------

ISA - ALL DEPARTMENTS

\$187.00

ITC ELECTRICAL TECHN

ITC ELECTRICAL TECHN	WWTP Operations	Centrifuge Spare Parts & Labor	\$2,241.35
----------------------	-----------------	--------------------------------	------------

ITC ELECTRICAL TECHN	WWTP Operations	WWTP Operations Building Trans	\$41,687.50
----------------------	-----------------	--------------------------------	-------------

<i>ITC ELECTRICAL TECHN - Total For WWTP Operations</i>			<i>\$43,928.85</i>
ITC ELECTRICAL TECHN - ALL DEPARTMENTS			\$43,928.85

J.J. KELLER & ASSOCI

J.J. KELLER & ASSOCI	Refuse - Residential	CDL Theory Training - A. Rickert	\$250.00
<i>J.J. KELLER & ASSOCI - Total For Refuse - Residential</i>			<i>\$250.00</i>
J.J. KELLER & ASSOCI - ALL DEPARTMENTS			\$250.00

JACOBS ENGINEERING G

JACOBS ENGINEERING G	WWTP Operations	Engineering Services with Jaco	\$13,180.00
<i>JACOBS ENGINEERING G - Total For WWTP Operations</i>			<i>\$13,180.00</i>
JACOBS ENGINEERING G - ALL DEPARTMENTS			\$13,180.00

JOHNNY APPLESEED, IN

JOHNNY APPLESEED, IN	Balefill - Diversion & Special	Transplantation labor of trees	\$2,112.42
JOHNNY APPLESEED, IN	Balefill - Diversion & Special	Transplantation of trees	\$4,695.74
<i>JOHNNY APPLESEED, IN - Total For Balefill - Diversion & Special</i>			<i>\$6,808.16</i>
JOHNNY APPLESEED, IN - ALL DEPARTMENTS			\$6,808.16

JONAS SOFTWARE USA

JONAS SOFTWARE USA	Golf - Operations	Maintenance Fee	\$349.00
<i>JONAS SOFTWARE USA - Total For Golf - Operations</i>			<i>\$349.00</i>
JONAS SOFTWARE USA - ALL DEPARTMENTS			\$349.00

KINSCO LLC

KINSCO LLC	Fire-EMS Operations	Uniform supplies	\$165.00
KINSCO LLC	Fire-EMS Operations	Uniform supplies	\$42.00
KINSCO LLC	Fire-EMS Operations	Uniform supplies	\$143.00
KINSCO LLC	Fire-EMS Operations	Uniform supplies	\$42.00
KINSCO LLC	Fire-EMS Operations	Uniform supplies	\$38.00
KINSCO LLC	Fire-EMS Operations	Uniform supplies	\$33.00
KINSCO LLC	Fire-EMS Operations	Uniform supplies	\$624.26

KINSCO LLC	Fire-EMS Operations	Uniform supplies	\$679.90
KINSCO LLC	Fire-EMS Operations	Uniform supplies	\$624.26
<i>KINSCO LLC - Total For Fire-EMS Operations</i>			<i>\$2,391.42</i>
KINSCO LLC	Fire-EMS Training	Uniform supplies	\$300.00
<i>KINSCO LLC - Total For Fire-EMS Training</i>			<i>\$300.00</i>
KINSCO LLC - ALL DEPARTMENTS			\$2,691.42

KISTLER TENT

KISTLER TENT	Community Development	TENT AND AWNING SHOPS	\$160.00
<i>KISTLER TENT - Total For Community Development</i>			<i>\$160.00</i>
KISTLER TENT - ALL DEPARTMENTS			\$160.00

KNIFE RIVER/JTL

KNIFE RIVER/JTL	Streets	Snow removal	\$6,380.35
KNIFE RIVER/JTL	Streets	1/2" Plant Mix	\$916.32
KNIFE RIVER/JTL	Streets	1/2" Plant Mix	\$940.24
KNIFE RIVER/JTL	Streets	1/2" Plant Mix	\$941.16
KNIFE RIVER/JTL	Streets	1/2" Plant Mix	\$924.60
KNIFE RIVER/JTL	Streets	1/2" Plant Mix	\$551.08
KNIFE RIVER/JTL	Streets	1/2" Plant Mix	\$1,418.12
KNIFE RIVER/JTL	Streets	1/2" Plant Mix	\$1,389.20
KNIFE RIVER/JTL	Streets	1/2" Plant Mix	\$930.12
<i>KNIFE RIVER/JTL - Total For Streets</i>			<i>\$14,391.19</i>
KNIFE RIVER/JTL - ALL DEPARTMENTS			\$14,391.19

KUBWATER RESOURCES,

KUBWATER RESOURCES,	WWTP Operations	Zetag 7593	\$8,300.00
<i>KUBWATER RESOURCES, - Total For WWTP Operations</i>			<i>\$8,300.00</i>
KUBWATER RESOURCES, - ALL DEPARTMENTS			\$8,300.00

LAMAR OUTDOOR ADVERT

LAMAR OUTDOOR ADVERT	Police Grants Fund	Digital Poster / Advertising - 4/03/23 to 4/30	\$1,400.00
<i>LAMAR OUTDOOR ADVERT - Total For Police Grants Fund</i>			<i>\$1,400.00</i>

LAMAR OUTDOOR ADVERT - ALL DEPARTMENTS

\$1,400.00

LARAMIE AREA VISITOR

LARAMIE AREA VISITOR	Fire-EMS Training	BUSINESS SERVICES NOT ELSEWHERE CLASSI	\$225.00
----------------------	-------------------	--	----------

<i>LARAMIE AREA VISITOR - Total For Fire-EMS Training</i>			\$225.00
---	--	--	----------

LARAMIE AREA VISITOR - ALL DEPARTMENTS

\$225.00

LINKO TECHNOLOGY

LINKO TECHNOLOGY	WWTP Operations	Wims renewal	\$2,602.00
------------------	-----------------	--------------	------------

<i>LINKO TECHNOLOGY - Total For WWTP Operations</i>			\$2,602.00
---	--	--	------------

LINKO TECHNOLOGY - ALL DEPARTMENTS

\$2,602.00

LISA M HUBBARD

LISA M HUBBARD	Police Administration	Professional consultant services	\$275.00
----------------	-----------------------	----------------------------------	----------

<i>LISA M HUBBARD - Total For Police Administration</i>			\$275.00
---	--	--	----------

LISA M HUBBARD - ALL DEPARTMENTS

\$275.00

LOAF N JUG #0103

LOAF N JUG #0103	Fire-EMS Operations	Fuel	\$56.89
------------------	---------------------	------	---------

LOAF N JUG #0103	Fire-EMS Operations	Fuel	\$69.63
------------------	---------------------	------	---------

LOAF N JUG #0103	Fire-EMS Operations	Fuel	\$80.79
------------------	---------------------	------	---------

<i>LOAF N JUG #0103 - Total For Fire-EMS Operations</i>			\$207.31
---	--	--	----------

LOAF N JUG #0103 - ALL DEPARTMENTS

\$207.31

LOAF N JUG #0119

LOAF N JUG #0119	Fire-EMS Operations	Fuel for travel	\$54.64
------------------	---------------------	-----------------	---------

<i>LOAF N JUG #0119 - Total For Fire-EMS Operations</i>			\$54.64
---	--	--	---------

LOAF N JUG #0119 - ALL DEPARTMENTS

\$54.64

LOAF N JUG #0156

LOAF N JUG #0156	Fire-EMS Operations	Fuel while traveling	\$36.27
------------------	---------------------	----------------------	---------

LOAF N JUG #0156 - Total For Fire-EMS Operations \$36.27

LOAF N JUG #0156 - ALL DEPARTMENTS \$36.27

LONG BUILDING TECHNO

LONG BUILDING TECHNO Capital Projects Fund HVAC Controls Upgrade - materials & labor \$3,548.34

LONG BUILDING TECHNO - Total For Capital Projects Fund \$3,548.34

LONG BUILDING TECHNO - ALL DEPARTMENTS \$3,548.34

LONG REIMER WINEGAR

LONG REIMER WINEGAR City Clerk LEGAL SERVICES, ATTORNEYS \$110.00

LONG REIMER WINEGAR - Total For City Clerk \$110.00

LONG REIMER WINEGAR - ALL DEPARTMENTS \$110.00

LYFT RIDE SUN

LYFT RIDE SUN Health Insurance Fund WORKHUMAN CONFERENCE - TRANSPORTA \$23.97

LYFT RIDE SUN - Total For Health Insurance Fund \$23.97

LYFT RIDE SUN - ALL DEPARTMENTS \$23.97

MARRIOTT ORLANDO WC

MARRIOTT ORLANDO WC Information Services MARRIOTT \$29.82

MARRIOTT ORLANDO WC - Total For Information Services \$29.82

MARRIOTT ORLANDO WC - ALL DEPARTMENTS \$29.82

MD MEDICAL RESOURCES

MD MEDICAL RESOURCES Capital Projects Fund CRC Fitness Project; Equipment \$3,300.00

MD MEDICAL RESOURCES - Total For Capital Projects Fund \$3,300.00

MD MEDICAL RESOURCES Rec Center - Operations Repair Service and Materials for CRC Fitness \$1,750.00

MD MEDICAL RESOURCES - Total For Rec Center - Operations \$1,750.00

MD MEDICAL RESOURCES - ALL DEPARTMENTS \$5,050.00

MENARDS CASPER WY

MENARDS CASPER WY	Buildings & Structures Fund	Custodial Supplies for Parking Garage - Mena	\$29.88
MENARDS CASPER WY	Buildings & Structures Fund	Plumbing repair supplies for Rec Center - Me	\$99.98
<i>MENARDS CASPER WY - Total For Buildings & Structures Fund</i>			<i>\$129.86</i>
MENARDS CASPER WY	Cemetery	shop supplies	\$323.41
<i>MENARDS CASPER WY - Total For Cemetery</i>			<i>\$323.41</i>
MENARDS CASPER WY	Parks - Parks Maint.	Litter pick-up Trash bags	\$256.31
<i>MENARDS CASPER WY - Total For Parks - Parks Maint.</i>			<i>\$256.31</i>
MENARDS CASPER WY	Regional Water Operations	HVAC Filters - Machinery Supplies	\$87.67
<i>MENARDS CASPER WY - Total For Regional Water Operations</i>			<i>\$87.67</i>
MENARDS CASPER WY	Water Distribution	NIPPLES FOR CURB BOX- WATER & SEWER LI	\$448.82
<i>MENARDS CASPER WY - Total For Water Distribution</i>			<i>\$448.82</i>
MENARDS CASPER WY - ALL DEPARTMENTS			\$1,246.07

MIDLAND IMPLEMENT, I

MIDLAND IMPLEMENT, I	Golf - Operations	Golf Aluminum/Plastic Cup, Flagstick & Cut S	\$1,160.55
<i>MIDLAND IMPLEMENT, I - Total For Golf - Operations</i>			<i>\$1,160.55</i>
MIDLAND IMPLEMENT, I - ALL DEPARTMENTS			\$1,160.55

Monson

Monson	Buildings & Structures Fund	Monthly Janitorial Service	\$8,868.52
<i>Monson - Total For Buildings & Structures Fund</i>			<i>\$8,868.52</i>
Monson - ALL DEPARTMENTS			\$8,868.52

MOUNTAIN ALARM FIRE

MOUNTAIN ALARM FIRE	Balefill - Disposal & Landfill	Annual Fire Alarm Inspections for Solid Wast	\$1,914.50
<i>MOUNTAIN ALARM FIRE - Total For Balefill - Disposal & Landfill</i>			<i>\$1,914.50</i>
MOUNTAIN ALARM FIRE - ALL DEPARTMENTS			\$1,914.50

MOUNTAIN SPORTS

MOUNTAIN SPORTS	Hogadon - Operations	Uniform treatment	\$84.75
<i>MOUNTAIN SPORTS - Total For Hogadon - Operations</i>			<i>\$84.75</i>
MOUNTAIN SPORTS - ALL DEPARTMENTS			\$84.75

MOUNTAIN STATES

MOUNTAIN STATES	Metro Animal Control	Printing Service - contact notice/complaint	\$167.07
MOUNTAIN STATES	Metro Animal Control	Printing Service - veterinary quarantine agre	\$167.07
MOUNTAIN STATES	Metro Animal Control	Printing Service - bite report	\$81.09
MOUNTAIN STATES	Metro Animal Control	Printing Service - home quarantine agreeme	\$167.07
MOUNTAIN STATES	Metro Animal Control	Printing Service - relinquishment form	\$168.92
MOUNTAIN STATES	Metro Animal Control	Printing Service - post bite report	\$81.09
<i>MOUNTAIN STATES - Total For Metro Animal Control</i>			\$832.31
MOUNTAIN STATES	Municipal Court	Printing service - envelopes	\$148.70
<i>MOUNTAIN STATES - Total For Municipal Court</i>			\$148.70
MOUNTAIN STATES	Police Administration	Printing service - business cards	\$138.47
<i>MOUNTAIN STATES - Total For Police Administration</i>			\$138.47
MOUNTAIN STATES - ALL DEPARTMENTS			\$1,119.48

MURDOCH'S RANCH&HOME

MURDOCH'S RANCH&HOM	Balefill - Disposal & Landfill	SPIKE KIT TO PREVENT BIRDS IN STORAGE AR	\$218.80
<i>MURDOCH'S RANCH&HOME - Total For Balefill - Disposal & Landfill</i>			\$218.80
MURDOCH'S RANCH&HOM	Cemetery	safety supplies	\$65.94
<i>MURDOCH'S RANCH&HOME - Total For Cemetery</i>			\$65.94
MURDOCH'S RANCH&HOM	Police Grants Fund	MISCELLANEOUS AND RETAIL STORES Dog cr	\$239.98
<i>MURDOCH'S RANCH&HOME - Total For Police Grants Fund</i>			\$239.98
MURDOCH'S RANCH&HOM	Refuse - Commercial	SHOVEL TRK#2288 COMMERCIAL FL 2018	\$39.99
<i>MURDOCH'S RANCH&HOME - Total For Refuse - Commercial</i>			\$39.99
MURDOCH'S RANCH&HOM	Weed & Pest Fund	Shears	\$79.96
<i>MURDOCH'S RANCH&HOME - Total For Weed & Pest Fund</i>			\$79.96
MURDOCH'S RANCH&HOME - ALL DEPARTMENTS			\$644.67

NAPA AUTO PARTS CORP

NAPA AUTO PARTS CORP	Fire-EMS Operations	Floor Dry	\$626.25
<i>NAPA AUTO PARTS CORP - Total For Fire-EMS Operations</i>			\$626.25
NAPA AUTO PARTS CORP	Fleet Maintenance Fund	CONSUMABLES & SM TOOLS	\$1,516.50
NAPA AUTO PARTS CORP	Fleet Maintenance Fund	IBS EXPENSES	\$12,914.99
NAPA AUTO PARTS CORP	Fleet Maintenance Fund	INS. CLAIMS	\$1,965.48

NAPA AUTO PARTS CORP	Fleet Maintenance Fund	PARTS	\$90,181.60
<i>NAPA AUTO PARTS CORP - Total For Fleet Maintenance Fund</i>			<i>\$106,578.57</i>
NAPA AUTO PARTS CORP - ALL DEPARTMENTS			\$107,204.82

NATRONA COUNTY OFFIC

NATRONA COUNTY OFFIC	City Clerk	Dtentn Cntr JPB-Kitchen Hood/Sprinkler Hea	\$2,756.24
<i>NATRONA COUNTY OFFIC - Total For City Clerk</i>			<i>\$2,756.24</i>
NATRONA COUNTY OFFIC	Weed & Pest Fund	Mosquito Matching Fund	\$65,000.00
<i>NATRONA COUNTY OFFIC - Total For Weed & Pest Fund</i>			<i>\$65,000.00</i>
NATRONA COUNTY OFFIC - ALL DEPARTMENTS			\$67,756.24

NCL OF WISCONSIN INC

NCL OF WISCONSIN INC	WWTP Operations	Lab supplies	\$117.93
<i>NCL OF WISCONSIN INC - Total For WWTP Operations</i>			<i>\$117.93</i>
NCL OF WISCONSIN INC - ALL DEPARTMENTS			\$117.93

NORCO, INC.

NORCO, INC.	Balefill - Disposal & Landfill	SAFETY SUPPLIES FOR BALER	\$183.21
<i>NORCO, INC. - Total For Balefill - Disposal & Landfill</i>			<i>\$183.21</i>
NORCO, INC.	Buildings & Structures Fund	Latex gloves, facial tissue & garbage bags	\$127.16
NORCO, INC.	Buildings & Structures Fund	Lodge supplies	\$361.61
<i>NORCO, INC. - Total For Buildings & Structures Fund</i>			<i>\$488.77</i>
NORCO, INC.	Metro Animal Shelter	Disinfectant bleach, dish soap & icemelt	\$230.42
<i>NORCO, INC. - Total For Metro Animal Shelter</i>			<i>\$230.42</i>
NORCO, INC.	Refuse - Recycling	Garbage bags for depots	\$312.60
NORCO, INC.	Refuse - Recycling	Brush-Cyl-180 for floor scrubber	\$510.26
<i>NORCO, INC. - Total For Refuse - Recycling</i>			<i>\$822.86</i>
NORCO, INC.	Water Meters	INSTRUMENT CALIBRATION- OTHER MATERI	\$300.00
<i>NORCO, INC. - Total For Water Meters</i>			<i>\$300.00</i>
NORCO, INC.	WWTP Operations	Sensor	\$117.72
<i>NORCO, INC. - Total For WWTP Operations</i>			<i>\$117.72</i>
NORCO, INC. - ALL DEPARTMENTS			\$2,142.98

NORTHERN LIGHTS MANU

NORTHERN LIGHTS MANU	Refuse - Commercial	Trash bin rebuild -8yd trash container	\$2,400.00
NORTHERN LIGHTS MANU	Refuse - Commercial	Rebuild plat form TRK#2315 delivery truck 2	\$4,900.00
<i>NORTHERN LIGHTS MANU - Total For Refuse - Commercial</i>			<i>\$7,300.00</i>
NORTHERN LIGHTS MANU - ALL DEPARTMENTS			\$7,300.00

NORTHWEST CONTRACTOR

NORTHWEST CONTRACTOR	Balefill - Disposal & Landfill	115V Mixer for Landscape Project	\$840.00
<i>NORTHWEST CONTRACTOR - Total For Balefill - Disposal & Landfill</i>			<i>\$840.00</i>
NORTHWEST CONTRACTOR - ALL DEPARTMENTS			\$840.00

NVA CASPER VETERINAR

NVA CASPER VETERINAR	Metro Animal Shelter	Veterinary services	\$35.00
<i>NVA CASPER VETERINAR - Total For Metro Animal Shelter</i>			<i>\$35.00</i>
NVA CASPER VETERINAR	Police Administration	Veterinary Services	\$488.60
NVA CASPER VETERINAR	Police Administration	Veterinary Services	\$260.37
<i>NVA CASPER VETERINAR - Total For Police Administration</i>			<i>\$748.97</i>
NVA CASPER VETERINAR - ALL DEPARTMENTS			\$783.97

ODP BUS SOL LLC

ODP BUS SOL LLC	Finance	TONER CARTRIDGE	\$147.96
<i>ODP BUS SOL LLC - Total For Finance</i>			<i>\$147.96</i>
ODP BUS SOL LLC - ALL DEPARTMENTS			\$147.96

OHIO UAV SERVICES LL

OHIO UAV SERVICES LL	Police Administration	Drone, battery charger, fly more kit, etc	\$9,206.00
<i>OHIO UAV SERVICES LL - Total For Police Administration</i>			<i>\$9,206.00</i>
OHIO UAV SERVICES LL - ALL DEPARTMENTS			\$9,206.00

ORIGINAL WATERMEN IN

ORIGINAL WATERMEN IN	Aquatics - Operations	Lifeguard Uniform Suits	\$1,500.00
----------------------	-----------------------	-------------------------	------------

<i>ORIGINAL WATERMEN IN - Total For Aquatics - Operations</i>			<i>\$1,500.00</i>
ORIGINAL WATERMEN IN	Aquatics- Marion Kreiner Op	Lifeguard Uniform Suits	\$101.00
<i>ORIGINAL WATERMEN IN - Total For Aquatics- Marion Kreiner Oper.</i>			<i>\$101.00</i>
ORIGINAL WATERMEN IN	Aquatics- Mike Sedar Oper.	Lifeguard Uniform Suits	\$827.00
<i>ORIGINAL WATERMEN IN - Total For Aquatics- Mike Sedar Oper.</i>			<i>\$827.00</i>
ORIGINAL WATERMEN IN	Aquatics- Paradise Valley Op	Lifeguard Uniform Suits	\$486.77
<i>ORIGINAL WATERMEN IN - Total For Aquatics- Paradise Valley Oper</i>			<i>\$486.77</i>
ORIGINAL WATERMEN IN - ALL DEPARTMENTS			\$2,914.77

PANERA BREAD

PANERA BREAD	Health Insurance Fund	2023 Workforce Summit - Cheyenne	\$21.60
<i>PANERA BREAD - Total For Health Insurance Fund</i>			<i>\$21.60</i>
PANERA BREAD - ALL DEPARTMENTS			\$21.60

PETSMART #3082

PETSMART #3082	Metro Animal Shelter	PET SHOPS-PET FOOD AND SUPPLY STORES F	\$99.95
PETSMART #3082	Metro Animal Shelter	PET SHOPS-PET FOOD AND SUPPLY STORES	\$74.99
PETSMART #3082	Metro Animal Shelter	PET SHOPS-PET FOOD AND SUPPLY STORES i	\$29.96
<i>PETSMART #3082 - Total For Metro Animal Shelter</i>			<i>\$204.90</i>
PETSMART #3082 - ALL DEPARTMENTS			\$204.90

PIZZA HUT 035957

PIZZA HUT 035957	Balefill - Disposal & Landfill	BALER CREW POST SNOW STORM SAFETY TA	\$29.38
<i>PIZZA HUT 035957 - Total For Balefill - Disposal & Landfill</i>			<i>\$29.38</i>
PIZZA HUT 035957 - ALL DEPARTMENTS			\$29.38

POPE CONSTRUCTION,IN

POPE CONSTRUCTION,IN	Capital Projects Fund	Contract Withholding: 22300158	\$7,072.76
<i>POPE CONSTRUCTION,IN - Total For Capital Projects Fund</i>			<i>\$7,072.76</i>
POPE CONSTRUCTION,IN - ALL DEPARTMENTS			\$7,072.76

POWER SVC.,INC.

POWER SVC.,INC.	Public Safety Communication	PSCC Mountain Generator Reprogramming	\$1,230.88
<i>POWER SVC.,INC. - Total For Public Safety Communications</i>			<i>\$1,230.88</i>
POWER SVC.,INC. - ALL DEPARTMENTS			\$1,230.88

PPT HOLDINGS I LLC

PPT HOLDINGS I LLC	Information Services	Storage Maintenance Renewal	\$8,668.08
<i>PPT HOLDINGS I LLC - Total For Information Services</i>			<i>\$8,668.08</i>
PPT HOLDINGS I LLC - ALL DEPARTMENTS			\$8,668.08

PTI PEAKTECH TELPAR

PTI PEAKTECH TELPAR	Balefill - Disposal & Landfill	RECEIPT TAPE FOR WASTE WIZRAD	\$264.90
<i>PTI PEAKTECH TELPAR - Total For Balefill - Disposal & Landfill</i>			<i>\$264.90</i>
PTI PEAKTECH TELPAR - ALL DEPARTMENTS			\$264.90

RAMSHORN CONSTRUCTIO

RAMSHORN CONSTRUCTIO	Streets	Snow removal	\$3,062.50
<i>RAMSHORN CONSTRUCTIO - Total For Streets</i>			<i>\$3,062.50</i>
RAMSHORN CONSTRUCTIO - ALL DEPARTMENTS			\$3,062.50

REVDANCE.TENTH HOUSE

REVDANCE.TENTH HOUSE	Rec Center - Operations	CRC Dance Recital Costumes	\$1,203.75
<i>REVDANCE.TENTH HOUSE - Total For Rec Center - Operations</i>			<i>\$1,203.75</i>
REVDANCE.TENTH HOUSE - ALL DEPARTMENTS			\$1,203.75

RICKS CUSTOMS

RICKS CUSTOMS	Fire-EMS Prevent & Inspect	Screen printing of FD logos on uniform clothi	\$73.64
<i>RICKS CUSTOMS - Total For Fire-EMS Prevent & Inspect</i>			<i>\$73.64</i>
RICKS CUSTOMS - ALL DEPARTMENTS			\$73.64

RICOH USA INC

RICOH USA INC	Community Development	Copier usage	\$195.64
---------------	-----------------------	--------------	----------

<i>RICOH USA INC - Total For Community Development</i>			\$195.64
RICOH USA INC - ALL DEPARTMENTS			\$195.64

RINK SYSTEMS

RINK SYSTEMS	Risk Management	Replacement Arena Shielding Claim #202-30	\$956.83
<i>RINK SYSTEMS - Total For Risk Management</i>			<i>\$956.83</i>
RINK SYSTEMS - ALL DEPARTMENTS			\$956.83

RIVER OAKS COMMUNICA

RIVER OAKS COMMUNICA	General Fund Revenue	Amer Tower-Verizon Wireless - Eligible Facili	\$895.00
<i>RIVER OAKS COMMUNICA - Total For General Fund Revenue</i>			<i>\$895.00</i>
RIVER OAKS COMMUNICA - ALL DEPARTMENTS			\$895.00

Rocky Mountain

Rocky Mountain	Regional Water Operations	Bulk Oxygen - Chemicals	\$141.56
Rocky Mountain	Regional Water Operations	Bulk Oxygen - Chemicals	\$4,317.12
<i>Rocky Mountain - Total For Regional Water Operations</i>			<i>\$4,458.68</i>
Rocky Mountain - ALL DEPARTMENTS			\$4,458.68

ROCKY MOUNTAIN POWER

ROCKY MOUNTAIN POWER	Aquatics - Operations	Acct #54730761-088 1	\$5,207.33
<i>ROCKY MOUNTAIN POWER - Total For Aquatics - Operations</i>			<i>\$5,207.33</i>
ROCKY MOUNTAIN POWER	Ash Street Building	Acct #54730761-154 1	\$213.90
<i>ROCKY MOUNTAIN POWER - Total For Ash Street Building</i>			<i>\$213.90</i>
ROCKY MOUNTAIN POWER	Balefill - Disposal & Landfill	Acct #54730761-090 7	\$16,729.60
<i>ROCKY MOUNTAIN POWER - Total For Balefill - Disposal & Landfill</i>			<i>\$16,729.60</i>
ROCKY MOUNTAIN POWER	Buildings & Structures Fund	Acct #54730761-089 9	\$104.69
<i>ROCKY MOUNTAIN POWER - Total For Buildings & Structures Fund</i>			<i>\$104.69</i>
ROCKY MOUNTAIN POWER	Fire-EMS Administration	Acct #54730761-141 8	\$802.87
<i>ROCKY MOUNTAIN POWER - Total For Fire-EMS Administration</i>			<i>\$802.87</i>
ROCKY MOUNTAIN POWER	Ft. Caspar Museum	Acct #54730761-098 0	\$685.61
<i>ROCKY MOUNTAIN POWER - Total For Ft. Caspar Museum</i>			<i>\$685.61</i>
ROCKY MOUNTAIN POWER	Golf - Operations	Acct #54730761-099 8	\$2,501.67

<i>ROCKY MOUNTAIN POWER - Total For Golf - Operations</i>			\$2,501.67
ROCKY MOUNTAIN POWER	Hogadon - Operations	Acct #54730761-126 9	\$5,735.14
<i>ROCKY MOUNTAIN POWER - Total For Hogadon - Operations</i>			\$5,735.14
ROCKY MOUNTAIN POWER	Metro Animal Shelter	Acct #54730761-102 0	\$1,068.01
<i>ROCKY MOUNTAIN POWER - Total For Metro Animal Shelter</i>			\$1,068.01
ROCKY MOUNTAIN POWER	Parks - Athletic Maint.	Acct #54730761-131 9	\$678.14
<i>ROCKY MOUNTAIN POWER - Total For Parks - Athletic Maint.</i>			\$678.14
ROCKY MOUNTAIN POWER	Parks - Parks Maint.	Acct #54730761-103 8	\$3,296.08
<i>ROCKY MOUNTAIN POWER - Total For Parks - Parks Maint.</i>			\$3,296.08
ROCKY MOUNTAIN POWER	Parks - Special Areas	Acct #54730761-132 7	\$2,161.08
ROCKY MOUNTAIN POWER	Parks - Special Areas	Acct #54730761-148 3	\$57.56
<i>ROCKY MOUNTAIN POWER - Total For Parks - Special Areas</i>			\$2,218.64
ROCKY MOUNTAIN POWER	Police Administration	Acct #54730761-104 6	\$296.26
<i>ROCKY MOUNTAIN POWER - Total For Police Administration</i>			\$296.26
ROCKY MOUNTAIN POWER	Public Safety Communication	Acct #54730761-146 7	\$235.02
<i>ROCKY MOUNTAIN POWER - Total For Public Safety Communications</i>			\$235.02
ROCKY MOUNTAIN POWER	Public Transit - CARES Act	Acct #54730761-156 6	\$476.25
<i>ROCKY MOUNTAIN POWER - Total For Public Transit - CARES Act</i>			\$476.25
ROCKY MOUNTAIN POWER	Regional Water Operations	Acct #60931133-012 8 - Electricity	\$1,050.15
ROCKY MOUNTAIN POWER	Regional Water Operations	Acct #60931133-006 0 - Electricity	\$246.72
ROCKY MOUNTAIN POWER	Regional Water Operations	Acct #60931133-005 2 - Electricity	\$115.67
ROCKY MOUNTAIN POWER	Regional Water Operations	Acct #60931133-011 0 - Electricity	\$1,421.16
ROCKY MOUNTAIN POWER	Regional Water Operations	Acct #60931133-013 6 - Electricity	\$792.17
ROCKY MOUNTAIN POWER	Regional Water Operations	Acct #60931133-017 7 - Electricity	\$602.58
ROCKY MOUNTAIN POWER	Regional Water Operations	Acct #60931133-016 9 - Booster - Electricity	\$1,705.86
ROCKY MOUNTAIN POWER	Regional Water Operations	Acct #60931133-018 5 - Electricity	\$2,876.97
ROCKY MOUNTAIN POWER	Regional Water Operations	Acct #60931133-002 9 - Electricity	\$158.00
ROCKY MOUNTAIN POWER	Regional Water Operations	Acct #60931133-009 4 - Split - Electricity	\$24,252.45
ROCKY MOUNTAIN POWER	Regional Water Operations	Acct #60931133-010 2 - Electricity	\$3,947.60
<i>ROCKY MOUNTAIN POWER - Total For Regional Water Operations</i>			\$37,169.33
ROCKY MOUNTAIN POWER	RWS - Booster Stations	Acct #60931133-008 6 - Booster - Electricity	\$1,825.66
ROCKY MOUNTAIN POWER	RWS - Booster Stations	Acct #60931133-014 4 - Booster - Electricity	\$26.20
ROCKY MOUNTAIN POWER	RWS - Booster Stations	Acct #60931133-001 1 - Booster - Electricity	\$25.16
ROCKY MOUNTAIN POWER	RWS - Booster Stations	Acct #60931133-015 1 - Booster - Electricity	\$46.30
ROCKY MOUNTAIN POWER	RWS - Booster Stations	Acct #60931133-021 9 - Booster - Electricity	\$24.27
ROCKY MOUNTAIN POWER	RWS - Booster Stations	Acct #60931133-022 7 - Booster - Electricity	\$27.25

ROCKY MOUNTAIN POWER	RWS - Booster Stations	Acct #60931133-003 7 - Booster - Electricity	\$2,181.77
ROCKY MOUNTAIN POWER	RWS - Booster Stations	Acct #60931133-009 4 - Split - Electricity	\$1,859.37
ROCKY MOUNTAIN POWER	RWS - Booster Stations	Acct #60931133-026 8 - Booster - Electricity	\$103.80
ROCKY MOUNTAIN POWER	RWS - Booster Stations	Acct #60931133-025 0 - Booster - Electricity	\$2,035.93
ROCKY MOUNTAIN POWER	RWS - Booster Stations	Acct #60931133-024 3 - Booster - Electricity	\$24.89
ROCKY MOUNTAIN POWER	RWS - Booster Stations	Acct #60931133-019 3 - Booster - Electricity	\$25.30
<i>ROCKY MOUNTAIN POWER - Total For RWS - Booster Stations</i>			<i>\$8,205.90</i>
ROCKY MOUNTAIN POWER	Sewer Wastewater Collection	Acct #54730761-105 3 lift station electricity	\$619.52
<i>ROCKY MOUNTAIN POWER - Total For Sewer Wastewater Collection</i>			<i>\$619.52</i>
ROCKY MOUNTAIN POWER	Water Distribution	Acct #54730761-107 9	\$1,830.84
<i>ROCKY MOUNTAIN POWER - Total For Water Distribution</i>			<i>\$1,830.84</i>
ROCKY MOUNTAIN POWER	Water Tanks	Acct #54730761-107 9	\$38,056.84
ROCKY MOUNTAIN POWER	Water Tanks	Acct #54730761-135 0	\$88.76
<i>ROCKY MOUNTAIN POWER - Total For Water Tanks</i>			<i>\$38,145.60</i>
ROCKY MOUNTAIN POWER	WWTP Operations	Acct #54730761-108 7	\$28,982.91
<i>ROCKY MOUNTAIN POWER - Total For WWTP Operations</i>			<i>\$28,982.91</i>
ROCKY MOUNTAIN POWER - ALL DEPARTMENTS			\$155,203.31

Rooter

Rooter	Buildings & Structures Fund	Sewer clog services	\$454.00
<i>Rooter - Total For Buildings & Structures Fund</i>			<i>\$454.00</i>
Rooter	Parks - Parks Maint.	Porta-John from R&R	\$104.40
Rooter	Parks - Parks Maint.	Porta-John from R&R	\$331.65
<i>Rooter - Total For Parks - Parks Maint.</i>			<i>\$436.05</i>
Rooter - ALL DEPARTMENTS			\$890.05

SAMS CLUB #6425

SAMS CLUB #6425	Balefill - Disposal & Landfill	office supplies for SW/Scalehouse/ Baler/ Tr	\$574.95
<i>SAMS CLUB #6425 - Total For Balefill - Disposal & Landfill</i>			<i>\$574.95</i>
SAMS CLUB #6425	Balefill - Diversion & Special	OFFICE SUPPLIES FOR SPECIAL WASTE	\$29.98
<i>SAMS CLUB #6425 - Total For Balefill - Diversion & Special</i>			<i>\$29.98</i>
SAMS CLUB #6425	Fire-EMS Operations	Station Supplies	\$229.30
<i>SAMS CLUB #6425 - Total For Fire-EMS Operations</i>			<i>\$229.30</i>
SAMS CLUB #6425	Police Administration	WHOLESALE CLUBS promotional ceremony	\$9.38

<i>SAMS CLUB #6425 - Total For Police Administration</i>			<i>\$9.38</i>
SAMS CLUB #6425	Public Transit - CARES Act	Operational Supplies	\$297.18
<i>SAMS CLUB #6425 - Total For Public Transit - CARES Act</i>			<i>\$297.18</i>
SAMS CLUB #6425	Refuse - Residential	office supplies for SW/Scalehouse/ Baler/ Tr	\$91.90
<i>SAMS CLUB #6425 - Total For Refuse - Residential</i>			<i>\$91.90</i>
SAMS CLUB #6425 - ALL DEPARTMENTS			\$1,232.69

SAMSCLUB #6425

SAMSCLUB #6425	Balefill - Disposal & Landfill	OFFICE SUPPLIES FOR Landfill/Special Waste	\$11.36
<i>SAMSCLUB #6425 - Total For Balefill - Disposal & Landfill</i>			<i>\$11.36</i>
SAMSCLUB #6425	Balefill - Diversion & Special	TRASH BAGS KCB CLEAN UP	\$119.88
SAMSCLUB #6425	Balefill - Diversion & Special	OFFICE SUPPLIES FOR Landfill/Special Waste	\$19.98
<i>SAMSCLUB #6425 - Total For Balefill - Diversion & Special</i>			<i>\$139.86</i>
SAMSCLUB #6425	Buildings & Structures Fund	Custodial Supplies for Ice Arena - Sams Club	\$256.76
<i>SAMSCLUB #6425 - Total For Buildings & Structures Fund</i>			<i>\$256.76</i>
SAMSCLUB #6425	Rec Center - Classes	CRC Spring Break Camp Snacks 2240023	\$108.96
<i>SAMSCLUB #6425 - Total For Rec Center - Classes</i>			<i>\$108.96</i>
SAMSCLUB #6425 - ALL DEPARTMENTS			\$516.94

SAN DIEGO CONV CTR C

SAN DIEGO CONV CTR C	Health Insurance Fund	WORKHUMAN CONFERENCE - MEALS	\$15.55
<i>SAN DIEGO CONV CTR C - Total For Health Insurance Fund</i>			<i>\$15.55</i>
SAN DIEGO CONV CTR C - ALL DEPARTMENTS			\$15.55

SHELL OIL 5744427920

SHELL OIL 5744427920	Fire-EMS Operations	Fuel	\$70.42
SHELL OIL 5744427920	Fire-EMS Operations	Fuel	\$82.26
SHELL OIL 5744427920	Fire-EMS Operations	Fuel	\$47.37
<i>SHELL OIL 5744427920 - Total For Fire-EMS Operations</i>			<i>\$200.05</i>
SHELL OIL 5744427920 - ALL DEPARTMENTS			\$200.05

SHERWIN-WILLIAMS COR

SHERWIN-WILLIAMS COR	Balefill - Disposal & Landfill	MATERIALS FOR PAINT TRUCKERS LOUNGE	\$156.18
----------------------	--------------------------------	-------------------------------------	----------

SHERWIN-WILLIAMS COR	Balefill - Disposal & Landfill	Paint & painting supplies FOR TRUCKERS LO	\$359.51
<i>SHERWIN-WILLIAMS COR - Total For Balefill - Disposal & Landfill</i>			<i>\$515.69</i>
SHERWIN-WILLIAMS COR - ALL DEPARTMENTS			\$515.69

SIX ROBBLEES NO

SIX ROBBLEES NO	Refuse - Residential	CROSS LINKS FOR CHAINS, FOR ALL TRUCKS	\$1,286.92
SIX ROBBLEES NO	Refuse - Residential	TIRE CHAINS FOR ALL TRUCKS	\$784.62
<i>SIX ROBBLEES NO - Total For Refuse - Residential</i>			<i>\$2,071.54</i>
SIX ROBBLEES NO - ALL DEPARTMENTS			\$2,071.54

SKYSNAX - DIA

SKYSNAX - DIA	Health Insurance Fund	WORKHUMAN CONFERENCE - MEALS	\$3.24
<i>SKYSNAX - DIA - Total For Health Insurance Fund</i>			<i>\$3.24</i>
SKYSNAX - DIA - ALL DEPARTMENTS			\$3.24

SMITH PSYCHOLOGICAL

SMITH PSYCHOLOGICAL	Police Career Services	Confidential legal or medical matters	\$400.00
SMITH PSYCHOLOGICAL	Police Career Services	Confidential legal or medical matters	\$800.00
SMITH PSYCHOLOGICAL	Police Career Services	Confidential legal or medical matters	\$500.00
<i>SMITH PSYCHOLOGICAL - Total For Police Career Services</i>			<i>\$1,700.00</i>
SMITH PSYCHOLOGICAL - ALL DEPARTMENTS			\$1,700.00

SONNYS RVS

SONNYS RVS	Streets	March Propane--6 Tickets	\$264.26
<i>SONNYS RVS - Total For Streets</i>			<i>\$264.26</i>
SONNYS RVS - ALL DEPARTMENTS			\$264.26

SQ ART 321 - CASPER

SQ ART 321 - CASPER	Ft. Caspar Museum	Participation in Museums of Casper passport	\$200.00
<i>SQ ART 321 - CASPER - Total For Ft. Caspar Museum</i>			<i>\$200.00</i>
SQ ART 321 - CASPER - ALL DEPARTMENTS			\$200.00

SQ COMPUTER PROFESS

SQ COMPUTER PROFESS	Metro Animal Shelter	COMPUTER MAINTENANCE,REPAIR & SERVI	\$17.95
SQ COMPUTER PROFESS	Metro Animal Shelter	COMPUTER MAINTENANCE,REPAIR & SERVI	\$15.00
SQ COMPUTER PROFESS	Metro Animal Shelter	COMPUTER MAINTENANCE,REPAIR & SERVI	\$60.94
<i>SQ COMPUTER PROFESS - Total For Metro Animal Shelter</i>			\$93.89
SQ COMPUTER PROFESS	Sewer Wastewater Collection	Printer maintenance	\$140.00
<i>SQ COMPUTER PROFESS - Total For Sewer Wastewater Collection</i>			\$140.00
SQ COMPUTER PROFESS	WWTP Regional Interceptors	UPS to replace Mills AP UPS	\$132.00
<i>SQ COMPUTER PROFESS - Total For WWTP Regional Interceptors</i>			\$132.00
SQ COMPUTER PROFESS - ALL DEPARTMENTS			\$365.89

SQ FCMA

SQ FCMA	General Fund Revenue	Books for resale in museum store	\$569.19
<i>SQ FCMA - Total For General Fund Revenue</i>			\$569.19
SQ FCMA - ALL DEPARTMENTS			\$569.19

SQ GYPSY JAVAS

SQ GYPSY JAVAS	Balefill - Disposal & Landfill	Hazardous Waste Training Meal Expense	\$17.48
<i>SQ GYPSY JAVAS - Total For Balefill - Disposal & Landfill</i>			\$17.48
SQ GYPSY JAVAS - ALL DEPARTMENTS			\$17.48

SQ MY EDUCATIONAL R

SQ MY EDUCATIONAL R	Balefill - Baler Processing	SCHOOLS AND EDUCATIONAL SERVICES NOT	\$22.00
<i>SQ MY EDUCATIONAL R - Total For Balefill - Baler Processing</i>			\$22.00
SQ MY EDUCATIONAL R	Buildings & Structures Fund	SCHOOLS AND EDUCATIONAL SERVICES NOT	\$44.00
<i>SQ MY EDUCATIONAL R - Total For Buildings & Structures Fund</i>			\$44.00
SQ MY EDUCATIONAL R	Police Administration	SCHOOLS AND EDUCATIONAL SERVICES NOT	\$44.00
<i>SQ MY EDUCATIONAL R - Total For Police Administration</i>			\$44.00
SQ MY EDUCATIONAL R	Risk Management	SCHOOLS AND EDUCATIONAL SERVICES NOT	\$22.00
<i>SQ MY EDUCATIONAL R - Total For Risk Management</i>			\$22.00
SQ MY EDUCATIONAL R	Weed & Pest Fund	SCHOOLS AND EDUCATIONAL SERVICES NOT	\$22.00
<i>SQ MY EDUCATIONAL R - Total For Weed & Pest Fund</i>			\$22.00

SQ MY EDUCATIONAL R - ALL DEPARTMENTS \$154.00

SQ PEDEN'S INC.

SQ PEDEN'S INC. Buildings & Structures Fund BAS Uniform Supplies - Pedens \$100.00

SQ PEDEN'S INC. - Total For Buildings & Structures Fund \$100.00

SQ PEDEN'S INC. - ALL DEPARTMENTS \$100.00

SQ PIZZA TROLLEY

SQ PIZZA TROLLEY Health Insurance Fund WORKHUMAN CONFERENCE - MEALS \$18.00

SQ PIZZA TROLLEY - Total For Health Insurance Fund \$18.00

SQ PIZZA TROLLEY - ALL DEPARTMENTS \$18.00

STAPLES

STAPLES Balefill - Diversion & Special Staples Home and Garden Show SW \$15.98

STAPLES - Total For Balefill - Diversion & Special \$15.98

STAPLES Fire-EMS Administration Ink Cartridges for St.2 \$235.98

STAPLES - Total For Fire-EMS Administration \$235.98

STAPLES Sewer Wastewater Collection office supplies \$54.77

STAPLES - Total For Sewer Wastewater Collection \$54.77

STAPLES - ALL DEPARTMENTS \$306.73

STARBUCKS STORE

STARBUCKS STORE Health Insurance Fund WORKHUMAN CONFERENCE - MEALS \$11.40

STARBUCKS STORE - Total For Health Insurance Fund \$11.40

STARBUCKS STORE - ALL DEPARTMENTS \$11.40

STATE OF WY.

STATE OF WY. Balefill - Disposal & Landfill Weights and Measures Renewal - License #1 \$40.00

STATE OF WY. - Total For Balefill - Disposal & Landfill \$40.00

STATE OF WY. - ALL DEPARTMENTS \$40.00

STATELINE NO 7 ARCHI

STATELINE NO 7 ARCHI	Capital Projects Fund	Architectural design for City	\$17,607.00
<i>STATELINE NO 7 ARCHI - Total For Capital Projects Fund</i>			<i>\$17,607.00</i>
STATELINE NO 7 ARCHI - ALL DEPARTMENTS			\$17,607.00

STELLAR PROGRAMMING

STELLAR PROGRAMMING	Refuse - Commercial	Technical Support-Citizen Request Work Ord	\$1,993.75
<i>STELLAR PROGRAMMING - Total For Refuse - Commercial</i>			<i>\$1,993.75</i>
STELLAR PROGRAMMING - ALL DEPARTMENTS			\$1,993.75

STOTZ EQUIPMENT

STOTZ EQUIPMENT	Fire-EMS Training	Chainsaw Parts	\$741.82
<i>STOTZ EQUIPMENT - Total For Fire-EMS Training</i>			<i>\$741.82</i>
STOTZ EQUIPMENT - ALL DEPARTMENTS			\$741.82

SUMMIT FIRE AND SECU

SUMMIT FIRE AND SECU	Buildings & Structures Fund	Fire Extinguisher Inspection for Ash St Bldg -	\$89.25
<i>SUMMIT FIRE AND SECU - Total For Buildings & Structures Fund</i>			<i>\$89.25</i>
SUMMIT FIRE AND SECU	WWTP Operations	Extinguisher service	\$106.50
<i>SUMMIT FIRE AND SECU - Total For WWTP Operations</i>			<i>\$106.50</i>
SUMMIT FIRE AND SECU - ALL DEPARTMENTS			\$195.75

SUMMITKENNELS.COM

SUMMITKENNELS.COM	Police Grants Fund	K9 training aids	\$89.95
<i>SUMMITKENNELS.COM - Total For Police Grants Fund</i>			<i>\$89.95</i>
SUMMITKENNELS.COM - ALL DEPARTMENTS			\$89.95

SUN COUNTRY DISTRIBU

SUN COUNTRY DISTRIBU	Aquatics - Operations	Granular Shock for the Outdoor Pools	\$507.01
<i>SUN COUNTRY DISTRIBU - Total For Aquatics - Operations</i>			<i>\$507.01</i>
SUN COUNTRY DISTRIBU	Aquatics- Washington Oper	Granular Shock for the Outdoor Pools	\$1,512.99

SUN COUNTRY DISTRIBU - Total For Aquatics- Washington Oper \$1,512.99

SUN COUNTRY DISTRIBU - ALL DEPARTMENTS **\$2,020.00**

SUTHERLANDS 2219

SUTHERLANDS 2219 Water Distribution HARDWARE FOR SAMPLE STATION STRUT SU \$16.60

SUTHERLANDS 2219 - Total For Water Distribution *\$16.60*

SUTHERLANDS 2219 Water Tanks PVC SHED- OTHER MATERIALS & SUPPLIES \$21.61

SUTHERLANDS 2219 - Total For Water Tanks *\$21.61*

SUTHERLANDS 2219 - ALL DEPARTMENTS **\$38.21**

SWI, LLC

SWI, LLC Balefill - Disposal & Landfill Construction project - not bui \$26,220.00

SWI, LLC Balefill - Disposal & Landfill Fencing/chain link replacement/LITTER FENC \$1,302.00

SWI, LLC - Total For Balefill - Disposal & Landfill *\$27,522.00*

SWI, LLC Risk Management Claim 2023054 Repair iron fence-Highland C \$4,010.00

SWI, LLC - Total For Risk Management *\$4,010.00*

SWI, LLC - ALL DEPARTMENTS **\$31,532.00**

TARGET SPECIALTY PRO

TARGET SPECIALTY PRO Parks - Athletic Maint. Frontier UAN / Hume N in liquid tote \$2,050.00

TARGET SPECIALTY PRO Parks - Athletic Maint. Custom Fertilizer \$168.36

TARGET SPECIALTY PRO - Total For Parks - Athletic Maint. *\$2,218.36*

TARGET SPECIALTY PRO Weed & Pest Fund Custom Fertilizer \$4,614.40

TARGET SPECIALTY PRO - Total For Weed & Pest Fund *\$4,614.40*

TARGET SPECIALTY PRO - ALL DEPARTMENTS **\$6,832.76**

TEE HIVE LLC

TEE HIVE LLC General Fund Revenue Tshirts for sale in gift shop \$308.00

TEE HIVE LLC - Total For General Fund Revenue *\$308.00*

TEE HIVE LLC - ALL DEPARTMENTS **\$308.00**

THE HOME DEPOT

THE HOME DEPOT	Buildings & Structures Fund	Area rug for new CMO space - Home Depot	\$34.98
<i>THE HOME DEPOT - Total For Buildings & Structures Fund</i>			<i>\$34.98</i>
THE HOME DEPOT	Hogadon - Operations	Lodge supplies	\$90.57
<i>THE HOME DEPOT - Total For Hogadon - Operations</i>			<i>\$90.57</i>
THE HOME DEPOT	Metro Animal Control	HOME SUPPLY WAREHOUSE STORES tow str	\$79.96
<i>THE HOME DEPOT - Total For Metro Animal Control</i>			<i>\$79.96</i>
THE HOME DEPOT	Parks - Urban Forestry	stump soil	\$11.88
THE HOME DEPOT	Parks - Urban Forestry	stump soil	\$8.91
THE HOME DEPOT	Parks - Urban Forestry	stump soil	\$11.88
<i>THE HOME DEPOT - Total For Parks - Urban Forestry</i>			<i>\$32.67</i>
THE HOME DEPOT	Traffic Control	Lag screws for sign installs	\$63.50
<i>THE HOME DEPOT - Total For Traffic Control</i>			<i>\$63.50</i>
THE HOME DEPOT	Weed & Pest Fund	supplies	\$37.19
<i>THE HOME DEPOT - Total For Weed & Pest Fund</i>			<i>\$37.19</i>
THE HOME DEPOT - ALL DEPARTMENTS			\$338.87

THE LIFEGUARD

THE LIFEGUARD	Aquatics - Operations	Hip Packs, Whistles	\$622.50
<i>THE LIFEGUARD - Total For Aquatics - Operations</i>			<i>\$622.50</i>
THE LIFEGUARD - ALL DEPARTMENTS			\$622.50

THE RADAR SHOP INC

THE RADAR SHOP INC	Police Administration	Antenna repair & re-certified unit - parts / la	\$191.00
<i>THE RADAR SHOP INC - Total For Police Administration</i>			<i>\$191.00</i>
THE RADAR SHOP INC - ALL DEPARTMENTS			\$191.00

The Tree Doctor

The Tree Doctor	Balefill - Disposal & Landfill	Inspection / Spring Deep Root / Application	\$748.00
The Tree Doctor	Balefill - Disposal & Landfill	Tree Inspection/Spring Deep Root/1ST Appli	\$748.00
<i>The Tree Doctor - Total For Balefill - Disposal & Landfill</i>			<i>\$1,496.00</i>
The Tree Doctor - ALL DEPARTMENTS			\$1,496.00

THE WASH LLC

THE WASH LLC	Police Administration	Car wash	\$86.22
<i>THE WASH LLC - Total For Police Administration</i>			\$86.22
THE WASH LLC - ALL DEPARTMENTS			\$86.22

TOP OFFICE PRODUCTS

TOP OFFICE PRODUCTS	Fleet Maintenance Fund	Copy Charge - March 2023	\$53.85
<i>TOP OFFICE PRODUCTS - Total For Fleet Maintenance Fund</i>			\$53.85
TOP OFFICE PRODUCTS	Parks - Parks Maint.	Copy Charge - March 2023	\$53.85
<i>TOP OFFICE PRODUCTS - Total For Parks - Parks Maint.</i>			\$53.85
TOP OFFICE PRODUCTS	Streets	Copy Charge - March 2023	\$53.85
<i>TOP OFFICE PRODUCTS - Total For Streets</i>			\$53.85
TOP OFFICE PRODUCTS - ALL DEPARTMENTS			\$161.55

TOTAL MECHANICAL SER

TOTAL MECHANICAL SER	Buildings & Structures Fund	Electronic feed valve repair - labor & materia	\$5,032.00
<i>TOTAL MECHANICAL SER - Total For Buildings & Structures Fund</i>			\$5,032.00
TOTAL MECHANICAL SER	Ice Arena - Operations	Electronic feed valve repair - labor & materia	\$4,000.00
<i>TOTAL MECHANICAL SER - Total For Ice Arena - Operations</i>			\$4,000.00
TOTAL MECHANICAL SER - ALL DEPARTMENTS			\$9,032.00

TRACTOR SUPPLY CO

TRACTOR SUPPLY CO	Metro Animal Shelter	MISCELLANEOUS AUTOMOTIVE DEALERS Fos	\$39.67
<i>TRACTOR SUPPLY CO - Total For Metro Animal Shelter</i>			\$39.67
TRACTOR SUPPLY CO	Weed & Pest Fund	hitch receivers	\$329.95
<i>TRACTOR SUPPLY CO - Total For Weed & Pest Fund</i>			\$329.95
TRACTOR SUPPLY CO - ALL DEPARTMENTS			\$369.62

TRETO CONST.

TRETO CONST.	Capital Projects Fund	Industrial Avenue Elm-David Co	\$26,030.36
<i>TRETO CONST. - Total For Capital Projects Fund</i>			\$26,030.36
TRETO CONST. - ALL DEPARTMENTS			\$26,030.36

TST RUSTIC ROOT

TST RUSTIC ROOT	Health Insurance Fund	WORKHUMAN CONFERENCE - MEALS	\$44.59
<i>TST RUSTIC ROOT - Total For Health Insurance Fund</i>			<i>\$44.59</i>
TST RUSTIC ROOT - ALL DEPARTMENTS			\$44.59

TYLER TECHNOLOGIES I

TYLER TECHNOLOGIES I	Customer Service	Tyler Connect Conference 2023 - San Antoni	\$549.50
<i>TYLER TECHNOLOGIES I - Total For Customer Service</i>			<i>\$549.50</i>
TYLER TECHNOLOGIES I	Finance	Tyler Connect Conference 2023 - San Antoni	\$549.50
<i>TYLER TECHNOLOGIES I - Total For Finance</i>			<i>\$549.50</i>
TYLER TECHNOLOGIES I - ALL DEPARTMENTS			\$1,099.00

UBER EATS

UBER EATS	Health Insurance Fund	WORKHUMAN CONFERENCE - MEALS	\$38.17
UBER EATS	Health Insurance Fund	WORKHUMAN CONFERENCE - MEALS	\$4.11
<i>UBER EATS - Total For Health Insurance Fund</i>			<i>\$42.28</i>
UBER EATS - ALL DEPARTMENTS			\$42.28

UBER TRIP

UBER TRIP	Information Services	TAXICABS/LIMOUSINES	\$8.96
UBER TRIP	Information Services	TAXICABS/LIMOUSINES	\$44.81
UBER TRIP	Information Services	TAXICABS/LIMOUSINES	\$35.70
UBER TRIP	Information Services	TAXICABS/LIMOUSINES	\$7.14
<i>UBER TRIP - Total For Information Services</i>			<i>\$96.61</i>
UBER TRIP - ALL DEPARTMENTS			\$96.61

UEI WATER PROGRAM

UEI WATER PROGRAM	Water Meters	UEI WATER PROGRAM JASON KEGLER- TRAV	\$25.00
<i>UEI WATER PROGRAM - Total For Water Meters</i>			<i>\$25.00</i>
UEI WATER PROGRAM - ALL DEPARTMENTS			\$25.00

UNIFORMS 2 GEAR

UNIFORMS 2 GEAR	Police Career Services	Uniform supplies	\$247.50
UNIFORMS 2 GEAR	Police Career Services	Uniform supplies	\$168.00

UNIFORMS 2 GEAR - Total For Police Career Services \$415.50

UNIFORMS 2 GEAR - ALL DEPARTMENTS \$415.50

UNION WIRELESS

UNION WIRELESS	Water Tanks	Upper Rock Creek Reservoir SCADA & Cell Ph	\$95.23
----------------	-------------	--	---------

UNION WIRELESS - Total For Water Tanks \$95.23

UNION WIRELESS - ALL DEPARTMENTS \$95.23

UNITED 0162473632

UNITED 0162473632	Customer Service	UNITED AIRLINES FLIGHT FROM TYLER CONN	\$265.00
UNITED 0162473632	Customer Service	UNITED AIRLINES TO TYLER CONNECT CONFE	\$288.40

UNITED 0162473632 - Total For Customer Service \$553.40

UNITED 0162473632 - ALL DEPARTMENTS \$553.40

UNITED 0169846906

UNITED 0169846906	Health Insurance Fund	WORKHUMAN CONFERENCE - BAG FEE	\$35.00
-------------------	-----------------------	--------------------------------	---------

UNITED 0169846906 - Total For Health Insurance Fund \$35.00

UNITED 0169846906 - ALL DEPARTMENTS \$35.00

UNIVERSITY OF WY.

UNIVERSITY OF WY.	Metro Animal Control	Inbound shipping charges	\$27.94
-------------------	----------------------	--------------------------	---------

UNIVERSITY OF WY. - Total For Metro Animal Control \$27.94

UNIVERSITY OF WY. - ALL DEPARTMENTS \$27.94

UPSLOPE MEDIA

UPSLOPE MEDIA	Balefill - Disposal & Landfill	Compost Yard Earth Day Compost Sale Adve	\$450.00
---------------	--------------------------------	--	----------

UPSLOPE MEDIA - Total For Balefill - Disposal & Landfill \$450.00

UPSLOPE MEDIA - ALL DEPARTMENTS

\$450.00

URGENT CARE OF CASPE

URGENT CARE OF CASPE	Property Insurance Fund	MEDICAL SERVICES & HEALTH PRACTITIONE	\$4,470.00
----------------------	-------------------------	---------------------------------------	------------

<i>URGENT CARE OF CASPE - Total For Property Insurance Fund</i>			\$4,470.00
---	--	--	------------

URGENT CARE OF CASPE - ALL DEPARTMENTS

\$4,470.00

USPS PO 5715580945

USPS PO 5715580945	Fire-EMS Administration	Certified Mail	\$8.13
--------------------	-------------------------	----------------	--------

<i>USPS PO 5715580945 - Total For Fire-EMS Administration</i>			\$8.13
---	--	--	--------

USPS PO 5715580945 - ALL DEPARTMENTS

\$8.13

VERIZON WIRELESS

VERIZON WIRELESS	Parks - Parks Maint.	Acct #342080735-00001	\$429.41
------------------	----------------------	-----------------------	----------

<i>VERIZON WIRELESS - Total For Parks - Parks Maint.</i>			\$429.41
--	--	--	----------

VERIZON WIRELESS	Public Safety Communication	Acct #465552982-00010	\$80.08
------------------	-----------------------------	-----------------------	---------

<i>VERIZON WIRELESS - Total For Public Safety Communications</i>			\$80.08
--	--	--	---------

VERIZON WIRELESS	Sewer Wastewater Collection	Acct #742239432-00002 remote device data	\$74.30
------------------	-----------------------------	--	---------

<i>VERIZON WIRELESS - Total For Sewer Wastewater Collection</i>			\$74.30
---	--	--	---------

VERIZON WIRELESS	Streets	Acct #242152162-00001	\$40.01
------------------	---------	-----------------------	---------

<i>VERIZON WIRELESS - Total For Streets</i>			\$40.01
---	--	--	---------

VERIZON WIRELESS	Water Distribution	Acct #542255605-00001	\$51.61
------------------	--------------------	-----------------------	---------

<i>VERIZON WIRELESS - Total For Water Distribution</i>			\$51.61
--	--	--	---------

VERIZON WIRELESS	Weed & Pest Fund	Acct #342080735-00001	\$200.05
------------------	------------------	-----------------------	----------

<i>VERIZON WIRELESS - Total For Weed & Pest Fund</i>			\$200.05
--	--	--	----------

VERIZON WIRELESS	WWTP Operations	Acct #842227834-00001	\$146.47
------------------	-----------------	-----------------------	----------

<i>VERIZON WIRELESS - Total For WWTP Operations</i>			\$146.47
---	--	--	----------

VERIZON WIRELESS - ALL DEPARTMENTS

\$1,021.93

VOIANCE LANGUAGE

VOIANCE LANGUAGE	Public Safety Communication	Interpretation Services	\$25.00
------------------	-----------------------------	-------------------------	---------

<i>VOIANCE LANGUAGE - Total For Public Safety Communications</i>			\$25.00
--	--	--	---------

VOIANCE LANGUAGE - ALL DEPARTMENTS \$25.00

VRC COMPANIES LLC

VRC COMPANIES LLC Municipal Court File destruction service \$57.88

VRC COMPANIES LLC Municipal Court File destruction service \$60.77

VRC COMPANIES LLC - Total For Municipal Court \$118.65

VRC COMPANIES LLC Police Administration File Destruction Service \$131.27

VRC COMPANIES LLC - Total For Police Administration \$131.27

VRC COMPANIES LLC - ALL DEPARTMENTS \$249.92

VZWRLSS MY VZ VB P

VZWRLSS MY VZ VB P Regional Water Operations WTP Operator Cell Phone \$87.50

VZWRLSS MY VZ VB P - Total For Regional Water Operations \$87.50

VZWRLSS MY VZ VB P - ALL DEPARTMENTS \$87.50

WAL-MART #1617

WAL-MART #1617 Balefill - Disposal & Landfill Landfill/Baler Bldg Operational Supplies \$9.48

WAL-MART #1617 - Total For Balefill - Disposal & Landfill \$9.48

WAL-MART #1617 Balefill - Diversion & Special Landfill/Baler Bldg Operational Supplies \$32.96

WAL-MART #1617 - Total For Balefill - Diversion & Special \$32.96

WAL-MART #1617 Metro Animal Shelter GROCERY STORES, SUPERMARKETS Foster pr \$76.22

WAL-MART #1617 - Total For Metro Animal Shelter \$76.22

WAL-MART #1617 - ALL DEPARTMENTS \$118.66

WAL-MART #3778

WAL-MART #3778 Ft. Caspar Museum Cleaning supplies for headstones \$11.46

WAL-MART #3778 - Total For Ft. Caspar Museum \$11.46

WAL-MART #3778 Metro Animal Shelter GROCERY STORES, SUPERMARKETS Foster pr \$33.84

WAL-MART #3778 - Total For Metro Animal Shelter \$33.84

WAL-MART #3778 Regional Water Operations Batteries - Office Supplies \$36.96

WAL-MART #3778 - Total For Regional Water Operations \$36.96

WAL-MART #3778 - ALL DEPARTMENTS \$82.26

WAMCO LABS, INC.

WAMCO LABS, INC.	WWTP Pretreatment	Reduced Chronic Toxicity Testing	\$1,100.00
<i>WAMCO LABS, INC. - Total For WWTP Pretreatment</i>			<i>\$1,100.00</i>
WAMCO LABS, INC. - ALL DEPARTMENTS			\$1,100.00

WATER TECHNOLOGY GRO

WATER TECHNOLOGY GRO	WWTP Regional Interceptors	Pump Rebuild - parts / labor	\$8,205.00
<i>WATER TECHNOLOGY GRO - Total For WWTP Regional Interceptors</i>			<i>\$8,205.00</i>
WATER TECHNOLOGY GRO - ALL DEPARTMENTS			\$8,205.00

WAYNE COLEMAN CONSTR

WAYNE COLEMAN CONSTR	Capital Projects Fund	Casper Skatepark Remediation	\$20,385.00
<i>WAYNE COLEMAN CONSTR - Total For Capital Projects Fund</i>			<i>\$20,385.00</i>
WAYNE COLEMAN CONSTR	Water Distribution	Construction project - not bui	\$31,673.71
<i>WAYNE COLEMAN CONSTR - Total For Water Distribution</i>			<i>\$31,673.71</i>
WAYNE COLEMAN CONSTR - ALL DEPARTMENTS			\$52,058.71

WEAR PARTS INC

WEAR PARTS INC	Balefill - Disposal & Landfill	TOOLS AND PARTS	\$26.50
<i>WEAR PARTS INC - Total For Balefill - Disposal & Landfill</i>			<i>\$26.50</i>
WEAR PARTS INC	Buildings & Structures Fund	Steam room repair supplies for Rec Center -	\$39.92
<i>WEAR PARTS INC - Total For Buildings & Structures Fund</i>			<i>\$39.92</i>
WEAR PARTS INC	WWTP Operations	Nuts and bolts	\$931.61
WEAR PARTS INC	WWTP Operations	Nuts and bolts	\$750.00
<i>WEAR PARTS INC - Total For WWTP Operations</i>			<i>\$1,681.61</i>
WEAR PARTS INC - ALL DEPARTMENTS			\$1,748.03

WEF MAIN

WEF MAIN	Sewer Wastewater Collection	training books for Collection license	\$243.98
<i>WEF MAIN - Total For Sewer Wastewater Collection</i>			<i>\$243.98</i>
WEF MAIN - ALL DEPARTMENTS			\$243.98

WEISSMAN'S THEATRICA

WEISSMAN'S THEATRICA	Rec Center - Operations	CRC Recital Costumes	\$103.88
<i>WEISSMAN'S THEATRICA - Total For Rec Center - Operations</i>			<i>\$103.88</i>
WEISSMAN'S THEATRICA - ALL DEPARTMENTS			\$103.88

WESTERN PLAINS LOGIS

WESTERN PLAINS LOGIS	Capital Projects Fund	Center St Enhance Construction	\$54,245.00
<i>WESTERN PLAINS LOGIS - Total For Capital Projects Fund</i>			<i>\$54,245.00</i>
WESTERN PLAINS LOGIS - ALL DEPARTMENTS			\$54,245.00

WESTERN WATER CONSUL

WESTERN WATER CONSUL	Capital Projects Fund	K St Imp-St Mary-Bryan Stk Eng	\$3,096.00
WESTERN WATER CONSUL	Capital Projects Fund	WWC Engineering Enhancements f	\$6,884.90
<i>WESTERN WATER CONSUL - Total For Capital Projects Fund</i>			<i>\$9,980.90</i>
WESTERN WATER CONSUL	Water Distribution	Poplar-CYtoCollins Design Wate	\$4,969.75
<i>WESTERN WATER CONSUL - Total For Water Distribution</i>			<i>\$4,969.75</i>
WESTERN WATER CONSUL - ALL DEPARTMENTS			\$14,950.65

WLC ENGINEERING - SU

WLC ENGINEERING - SU	Capital Projects Fund	Consultant: Westridge Addition	\$11,080.51
WLC ENGINEERING - SU	Capital Projects Fund	Consultant: Westridge Addition	\$14,357.06
<i>WLC ENGINEERING - SU - Total For Capital Projects Fund</i>			<i>\$25,437.57</i>
WLC ENGINEERING - SU	Engineering	Professional Land Surveying Services	\$435.00
<i>WLC ENGINEERING - SU - Total For Engineering</i>			<i>\$435.00</i>
WLC ENGINEERING - SU - ALL DEPARTMENTS			\$25,872.57

WM SUPERCENTER

WM SUPERCENTER	Balefill - Disposal & Landfill	OFFICE SUPPLIES FOR SCALEHOUSE	\$4.52
<i>WM SUPERCENTER - Total For Balefill - Disposal & Landfill</i>			<i>\$4.52</i>
WM SUPERCENTER	Balefill - Diversion & Special	OFFICE SUPPLIES FOR SW	\$8.82
<i>WM SUPERCENTER - Total For Balefill - Diversion & Special</i>			<i>\$8.82</i>
WM SUPERCENTER	Fire-EMS Training	Dolls for search and rescue training	\$23.94

<i>WM SUPERCENTER - Total For Fire-EMS Training</i>			<i>\$23.94</i>
WM SUPERCENTER	Hogadon - Operations	Lodge supplys	\$95.48
<i>WM SUPERCENTER - Total For Hogadon - Operations</i>			<i>\$95.48</i>
WM SUPERCENTER	Metro Animal Shelter	GROCERY STORES, SUPERMARKETS Foster pr	\$35.94
WM SUPERCENTER	Metro Animal Shelter	GROCERY STORES, SUPERMARKETS Foster pr	\$45.42
<i>WM SUPERCENTER - Total For Metro Animal Shelter</i>			<i>\$81.36</i>
WM SUPERCENTER	Public Transit - CARES Act	Supplies for 3 new Bus	\$128.89
<i>WM SUPERCENTER - Total For Public Transit - CARES Act</i>			<i>\$128.89</i>
WM SUPERCENTER	Regional Water Operations	Coffee & Calculators - Office Supplies	\$27.50
WM SUPERCENTER	Regional Water Operations	Sides for Joint Powers Board Meeting - Offic	\$19.08
<i>WM SUPERCENTER - Total For Regional Water Operations</i>			<i>\$46.58</i>
WM SUPERCENTER - ALL DEPARTMENTS			\$389.59

WPY DEANNA WHITE

WPY DEANNA WHITE	Police Administration	TRANSPORTATION SERVICES NOT ELSEWHERE	\$1,428.30
<i>WPY DEANNA WHITE - Total For Police Administration</i>			<i>\$1,428.30</i>
WPY DEANNA WHITE	Police Grants Fund	TRANSPORTATION SERVICES NOT ELSEWHERE	\$1,428.30
WPY DEANNA WHITE	Police Grants Fund	TRANSPORTATION SERVICES NOT ELSEWHERE	\$1,428.30
<i>WPY DEANNA WHITE - Total For Police Grants Fund</i>			<i>\$2,856.60</i>
WPY DEANNA WHITE - ALL DEPARTMENTS			\$4,284.90

WSP USA INC

WSP USA INC	Balefill - Disposal & Landfill	The City is undertaking a proj	\$2,615.00
<i>WSP USA INC - Total For Balefill - Disposal & Landfill</i>			<i>\$2,615.00</i>
WSP USA INC - ALL DEPARTMENTS			\$2,615.00

WWW.4PENS.COM

WWW.4PENS.COM	Public Transit - Operations	Marketing Pens	\$500.25
<i>WWW.4PENS.COM - Total For Public Transit - Operations</i>			<i>\$500.25</i>
WWW.4PENS.COM - ALL DEPARTMENTS			\$500.25

WY. LAW ENFORCEMENT

WY. LAW ENFORCEMENT	Police Career Services	Peace Officer Criminal Law & Procedures Tra	\$675.00
---------------------	------------------------	---	----------

WY. LAW ENFORCEMENT - Total For Police Career Services	\$675.00
--	----------

WY. LAW ENFORCEMENT - ALL DEPARTMENTS	\$675.00
--	-----------------

WY. MACHINERY CO.

WY. MACHINERY CO.	Balefill - Disposal & Landfill	Pit Loader with Solid Waste Handling Packag	\$365,290.32
-------------------	--------------------------------	---	--------------

WY. MACHINERY CO.	Balefill - Disposal & Landfill	Equipment SERVICE ON DEMO LOADER	\$597.97
-------------------	--------------------------------	----------------------------------	----------

WY. MACHINERY CO. - Total For Balefill - Disposal & Landfill	\$365,888.29
--	--------------

WY. MACHINERY CO. - ALL DEPARTMENTS	\$365,888.29
--	---------------------

WYOMING ASSOCIATION

WYOMING ASSOCIATION	Fire-EMS Administration	Membership Dues	\$140.00
---------------------	-------------------------	-----------------	----------

WYOMING ASSOCIATION - Total For Fire-EMS Administration	\$140.00
---	----------

WYOMING ASSOCIATION - ALL DEPARTMENTS	\$140.00
--	-----------------

WYOMING FIRST AID &

WYOMING FIRST AID &	Balefill - Disposal & Landfill	First Aid Supplies FOR SOLIDWASTE	\$89.17
---------------------	--------------------------------	-----------------------------------	---------

WYOMING FIRST AID & - Total For Balefill - Disposal & Landfill	\$89.17
--	---------

WYOMING FIRST AID &	Police Administration	First Aid Supplies	\$98.88
---------------------	-----------------------	--------------------	---------

WYOMING FIRST AID & - Total For Police Administration	\$98.88
---	---------

WYOMING FIRST AID &	Regional Water Operations	First Aid Supplies - Safety Equipment & Suppl	\$25.26
---------------------	---------------------------	---	---------

WYOMING FIRST AID & - Total For Regional Water Operations	\$25.26
---	---------

WYOMING FIRST AID & - ALL DEPARTMENTS	\$213.31
--	-----------------

XEROX CORPORATION

XEROX CORPORATION	Regional Water Operations	Copier Usage - Xerox - Office Supplies	\$207.03
-------------------	---------------------------	--	----------

XEROX CORPORATION - Total For Regional Water Operations	\$207.03
---	----------

XEROX CORPORATION - ALL DEPARTMENTS	\$207.03
--	-----------------

YOUTH CRISIS CENTER

YOUTH CRISIS CENTER	Capital Projects Fund	1%#16 Funding Youth Crisis Cen	\$34,905.00
---------------------	-----------------------	--------------------------------	-------------

YOUTH CRISIS CENTER - Total For Capital Projects Fund	\$34,905.00
---	-------------

YOUTH CRISIS CENTER - ALL DEPARTMENTS

\$34,905.00

ZONAR

ZONAR Refuse - Residential ZONAR PARTS \$2.00

ZONAR - Total For Refuse - Residential \$2.00

ZONAR - ALL DEPARTMENTS \$2.00

CITYWIDE BILLS AND CLAIMS TOTAL

\$2,642,706.71

I certify, under penalty of perjury, that this listing of vouchers and the items included therein for payment are correct and just in every respect.

SUBMITTED BY (Finance Dir) _____ DATE _____

DULY AUDITED BY (City Manager) _____ DATE _____

APPROVED BY (Mayor) _____ DATE _____

CITY of CASPER, WYOMING
 BILLS and CLAIMS ADDENDUM
 Council Meeting
 05/02/23

Additional Accounts Payable

03/29/23

Prewrits - IRS

IRS - Payment To Bring City Back Inline w/Requirements	176,451.98
	176,451.98

04/13/23

Prewrits - Travel Reimbursements, Sales Tax & Payroll Vendor/s

Alyssa Baedke - Travel Reimbursement	177.00
Jacci Warne - Travel Reimbursement	177.00
Jonathan Munday - Travel Reimbursement	177.00
Molly Nill - Travel Reimbursement	434.50
State of Wyo - Dept. of Revenue - Sales tax	764.76
State of Wyo Dept of Admin & Info - State of Wyo sponsored insurance plans	860,001.09
State of Wyo Dept of Admin & Info - State of Wyo sponsored insurance plans	3,181.71
	864,913.06

04/20/23

Prewrits - Travel Reimbursements, Petty Cash & AP Vendor

Scott Schell - Travel Reimbursement	407.00
Craig Burns - Travel Reimbursement	1,787.00
Lori Jackson - Travel Reimbursement	379.50
Nicholas Gassman - Travel Reimbursement	71.25
Sarah Winter - Travel Reimbursement	379.50
Ethan Yonker - Travel Reimbursement	71.25
First Interstate Bank - Petty Cash (Police Dept)	427.50
Bank of America - Pay Remaining Balance On March 2023 Stmt	7,278.58
	10,801.58

Total Additional AP \$ 1,052,166.62

April 21, 2023

MEMO TO: J. Carter Napier, City Manager *JCN*
FROM: Fleur Tremel, Assistant to the City Manager/City Clerk *FT*
Carla Mills-Laatsch, Licensing Specialist *CM*
SUBJECT: Establish Public Hearing for a new Winery Liquor License No. 1 for Gruner Brothers Brewing, d/b/a Gruner Brothers Brewing, Located at 1301 Wilkins Circle.

Meeting Type & Date

Regular Council Meeting
May 2, 2023

Action type

Establish Public Hearing
Minute Action

Recommendation

That Council, by minute action, establish May 16, 2023 as the Public Hearing date for a new Winery Liquor License No. 1 for Gruner Brothers Brewing, d/b/a Gruner Brothers Brewing, located at 1301 Wilkins Circle.

Summary

An application has been received requesting a new Winery Liquor License No. 1 for Gruner Brothers Brewing, d/b/a Gruner Brothers Brewing, located at 1301 Wilkins Circle.

Currently, there is a microbrew license located at this address and it will continue to operate. State Statue 12-5-201 (m) allows for multiple license or permit holders to operate in the same licensed building, as long as each licensee maintains distinct areas within the building.

If approved, this license will not be issued until all the required permits and inspections are complete. This applicant is going to produce cider which requires a winery permit. They are also requesting to sell other wines in their tasting room.

The State of Wyoming Liquor Division will duly review the application. The City of Casper Fire-EMS Department, City of Casper Community Development Department, and Natrona County Health Department will review this business and address to ensure compliance with local codes and ordinances.

As required by Municipal Code 05.08.080, a notice will be published in a local newspaper once a week for two consecutive weeks. As required by State Statute 12-4-104(a) it will be advertised on the City's website (www.casperwy.gov).

Financial Considerations

If approved, the City of Casper will receive \$426.

Oversight/Project Responsibility

Carla Mills-Laatsch, Licensing Specialist

Attachments

None

April 24, 2023

MEMO TO: J. Carter Napier, City Manager *JCN*

FROM: Fleur Tremel, Assistant to the City Manager/City Clerk *FT*
Carla Mills-Laatsch, Licensing Specialist *CM*

SUBJECT: Establish Public Hearing for Transfer of Ownership for Retail Liquor License No. 1 from Tin Shack, LLC d/b/a Poplar Wines & Spirits, Located at 1016 South Poplar Street to 1016 Poplar, Inc., d/b/a Poplar Wines & Spirits, Located at 1016 South Poplar Street.

Meeting Type & Date

Regular Council Meeting
May 2, 2023

Action type

Establish Public Hearing
Minute Action

Recommendation

That Council, by minute action, establish May 16, 2023 as the Public Hearing date for a transfer of ownership for liquor license no. 1 from Tin Shack, LLC d/b/a Poplar Wines & Spirits, located at 1016 South Poplar Street to 1016 Poplar, Inc., d/b/a Poplar Wines & Spirits, located at 1016 South Poplar Street.

Summary

An application has been received requesting a transfer of ownership for liquor license no. 1 from Tin Shack, LLC d/b/a Poplar Wines & Spirits, located at 1016 South Poplar Street to 1016 Poplar, Inc., d/b/a Poplar Wines & Spirits, located at 1016 South Poplar Street.

The intent is for 1016 Poplar, Inc to keep operating the liquor store and Vintage as currently operated. The current owners will stay on for a period of time to assist with the transition. They will be adding approximately 50 to 75 gaming machines. This will be located in an area currently used for storage.

The City of Casper Fire-EMS Department, City of Casper Community Development Department, and Natrona County Health Department will review this business and address to ensure compliance with local codes and ordinances.

As required by Municipal Code 05.08.080, a notice will be published in a local newspaper once a week for two consecutive weeks. As required by State Statute 12-4-104(a) it will be advertised on the City's website (www.casperwy.gov).

Financial Considerations

The transfer fee for this license is \$100.

Oversight/Project Responsibility

Carla Mills-Laatsch, Licensing Specialist

Attachments

None

April 21, 2023

MEMO TO: J. Carter Napier, City Manager 

FROM: Fleur Tremel, Assistant to the City Manager/City Clerk
Carla Mills-Laatsch, Licensing Specialist 

SUBJECT: Establish Public Hearing Date for a New Restaurant Liquor Licenses No. 51 for Movie Palace Inc., d/b/a Studio City Stadium 10 Cinemas, Located at 5020 East 2nd Street.

Meeting Type & Date

Regular Council Meeting
May 2, 2023

Action type

Establish Public Hearing
Minute Action

Recommendation

That Council, by minute action, establish May 16, 2023 as the Public Hearing date for a new restaurant liquor license No. 51 for Movie Palace Inc., d/b/a Studio City 10 Stadium Cinemas, located at 5020 East 2nd Street.

Summary

An application has been received requesting new restaurant liquor licenses, No. 51 for Movie Palace Inc., d/b/a Studio City 10 Stadium Cinemas, located at 5020 East 2nd Street.

In 2021, the Wyoming Liquor Laws regarding restaurants were amended. Restaurant liquor licenses now must have a dispensing area rather than a dispensing room. City Council will now approve a dispensing “area”, and the area will be age restricted to individuals 18 and over. No consumption can take place in this area.

The main requirement now is that meals must be prepared and served for on-premises consumption. Previously, the service of “only fry orders” or sandwiches and hamburgers did not qualify an establishment as a restaurant. Movie Palace Inc., plans to serve chicken sandwiches, French fries, hot dogs, pizza, and appetizers.

The State of Wyoming Liquor Division will duly review the application. The City of Casper Fire-EMS Department, City of Casper Community Development Department, and Natrona County Health Department will review this business and address to ensure compliance with local codes and ordinances.

As required by Municipal Code 05.08.080, a notice will be published in a local newspaper once a week for two consecutive weeks. As required by State Statute 12-4-104(a) it will be advertised on the City’s website (www.casperwy.gov).

Financial Considerations

The City of Casper will receive the prorated license fee, totaling \$1286.00 in revenue

Oversight/Project Responsibility

Carla Mills-Laatsch, Licensing Specialist

Attachments

none

April 20, 2023

MEMO TO: J. Carter Napier, City Manager *JCN*

FROM: Fleur Tremel, Assistant to the City Manager/City Clerk *FT*
Carla Mills-Laatsch, Licensing Specialist *CLM*

SUBJECT: Public Hearing for Transfer of Ownership for Retail Liquor License No. 37 From Charger Holdings, LLC d/b/a Charger Holdings, LLC, Located at 355 West Yellowstone to Bull Horn Brewing, LLC d/b/a Bull Horn Brewing, Located at 355 West Yellowstone Hwy.

Meeting Type & Date

Regular Council Meeting
May 2, 2023

Action type

Public Hearing
Minute Action

Recommendation

That Council, by minute action, consider the application for a transfer of ownership for liquor license no. 37 from Charger Holdings, LLC d/b/a Charger Holdings, LLC, located at 355 West Yellowstone to Bull Horn Brewing, LLC d/b/a Bull Horn Brewing, located at 355 West Yellowstone.

Summary

An application has been received requesting a transfer of ownership for retail liquor license no. 37 from Charger Holdings, LLC d/b/a Charger Holdings, LLC, located at 355 West Yellowstone to Bull Horn Brewing, LLC d/b/a Bull Horn Brewing, located at 355 West Yellowstone Hwy.

Charger Holdings, LLC d/b/a Yellowstone Garage was awarded this license on September 6, 2016 with the location restrictions in place. Charger Holdings, LLC d/b/a Yellowstone Garage closed in March of 2023 and remained non-operational until transferring this license to 307 Repairs, Inc., d/b/a Yellowstone Garage Bar and Grill on December 6, 2022. 307 Repairs, Inc., d/b/a Yellowstone Garage Bar and Grill closed in February of 2023. This license was transferred back to Charger Holdings, LLC at the March 21, 2023, council meeting.

If approved, this license will be active by May 26th, 2023. This applicant had a microbrewery license located at 2027 East Yellowstone Hwy Unit B. The brewery closed on April 4th, 2023, and will be moved to 355 West Yellowstone at a later time. State Statue 12-5-201 (m) allows for multiple license or permit holders to operate in the same licensed building, as long as each licensee maintains distinct areas within the building. This applicant plans to have a full kitchen and serve pub food. They will also have golf simulators, live music, and community events. They also plan to host a 5150 Rocks event formerly known as Rock the Block.

This liquor license has restrictions regarding the location. Unless removed by the City Council, this license will retain the existing stipulations placed upon it:

1. This Retail Liquor License shall be restricted to its use only at 355 West Yellowstone, and shall not be eligible for transfer to any other location. Its use on the real property may be transferred to a new owner or lessee of the real property upon approval by the City of Casper, Wyoming as provided by law. Upon the termination of the use of this Retail Liquor License by the applicant, a subsequent purchaser, or lessee of the real property from the applicant, or by operation of law, this Retail Liquor License shall revert to, and become the sole and separate property of the City of Casper, Wyoming.

Transfer Liquor License Stipulations

Per State Statute 12-4-103 (a) (iv)

(a) A license or permit authorized by this title shall not be held by, issued or transferred to:

(iv) Any licensee who fails to demonstrate that his licensed alcoholic or malt beverage enterprise will be operational in a planned but not physically functional building within one (1) year after a license or permit has been issued or transferred, or if holding a license, fails to open his business in a functional building within one (1) year after license issuance or transfer and remain operational thereafter. Upon a showing of good cause by the licensee and for an additional period of not to exceed one (1) year, the local licensing authority may extend the time period in which the business or enterprise of the licensee is required to become operational or open for business pursuant to this paragraph. Any license or permit in violation of this paragraph shall not be renewed by the local licensing authority and once the enterprise is operational or open for business, no licensee shall be eligible to repeat the grace periods made available by this paragraph without the consent of the local licensing authority due to extraordinary circumstances. For purposes of this paragraph "remain operational" means operational consecutively, in any license term year, for twelve (12) months or for not less than three (3) months if determined by the local licensing authority to be a seasonal operation.

As required by Municipal Code 05.08.080, a notice was published in a local newspaper once a week for two consecutive weeks. As required by State Statute 12-4-104(a) it is being advertised on the City's website (www.casperwy.gov).

Financial Considerations

The city will receive \$100 if this license is approved.

Oversight/Project Responsibility

Carla Mills-Laatsch, Licensing Specialist

Attachments

Copy of Application

Affidavit of Website Publication

NEW OR TRANSFER LIQUOR LICENSE OR PERMIT APPLICATION

FOR LIQUOR DIVISION USE ONLY		
Customer #:	_____	
Trf from:	_____	
Reviewer:	Initials	Date
Agent:		/ /
Mgr:		/ /

To be completed by City/County Clerk

License Fees: Annual Fee: \$ _____ Prorated Fee: \$ _____ Transfer Fee: \$ 100.00 Publishing Fee: \$ _____

Local License #: Retail 3637 Date filed with clerk: 04 10 23

Advertising Dates: (2 Weeks) April 19, 2023 & April 23, 2023 Hearing Date: 05 12 2023

Publishing Fee Direct Billed to Applicant:

License Term: 05 13 2023 through 03 31 2024
Month Day Year Month Day Year

LICENSING AUTHORITY: Begin publishing promptly. As W.S. 12-4-104(d) specifies: **NO LICENSING AUTHORITY SHALL APPROVE OR DENY THE APPLICATION UNTIL THE LIQUOR DIVISION HAS CERTIFIED THE APPLICATION IS COMPLETE.**

Applicant: Bull Horn Brewing LLC

Trade/Business Name (dba): Bull Horn Brewing

Building to be licensed/Building Address: 355 W Yellowstone Hwy
Number & Street

Casper WY 82601 Natrona
City State Zip County

Local Mailing Address: 355 W Yellowstone Hwy
Number & Street or P.O. Box

Casper WY 82601
City State Zip

Local Business Telephone Number: (307) 333-5492 Fax Number: ()

Business E-Mail Address: bullhornbrewing@gmail.com

FILING FOR	FILING IN (CHOOSE ONLY ONE)	FILING AS (CHOOSE ONLY ONE)
<input type="checkbox"/> NEW LICENSE	<input checked="" type="checkbox"/> CITY OF: <u>Casper</u>	<input type="checkbox"/> INDIVIDUAL
<input type="checkbox"/> TRANSFER OF LOCATION	<input type="checkbox"/> COUNTY OF: _____	<input type="checkbox"/> PARTNERSHIP
<input checked="" type="checkbox"/> TRANSFER OWNERSHIP	<input checked="" type="checkbox"/> ASSIGNMENT LETTER ATTACHED	<input type="checkbox"/> LP/LLP
FORMERLY HELD BY: <u>Charger Holdings LLC</u>		<input checked="" type="checkbox"/> LLC
		<input type="checkbox"/> CORPORATION
		<input type="checkbox"/> LTD PARTNERSHIP
		<input type="checkbox"/> ORGANIZATION
		<input type="checkbox"/> OTHER _____

TYPE OF LICENSE OR PERMIT (CHOOSE ONLY ONE)

<input type="checkbox"/> RETAIL LIQUOR LICENSE ON-PREMISE ONLY (BAR)	<input type="checkbox"/> RESTAURANT LIQUOR LICENSE	<input type="checkbox"/> MICROBREWERY PERMIT
<input type="checkbox"/> OFF-PREMISE ONLY (PACKAGE STORE)	<input type="checkbox"/> BAR AND GRILL LIQUOR LICENSE	<input type="checkbox"/> WINERY PERMIT
<input checked="" type="checkbox"/> COMBINATION ON/OFF PREMISE (BOTH BAR & PACKAGE STORE)	<input type="checkbox"/> RESORT LIQUOR LICENSE	<input type="checkbox"/> DISTILLERY SATELLITE PERMIT
	LIMITED RETAIL LIQUOR LICENSE (CLUB)	<input type="checkbox"/> WINERY SATELLITE PERMIT
	<input type="checkbox"/> VETERANS CLUB	<input type="checkbox"/> COUNTY MALT BEVERAGE PERMIT
	<input type="checkbox"/> FRATERNAL CLUB	<input type="checkbox"/> SPECIAL MALT BEVERAGE PERMIT
	<input type="checkbox"/> GOLF CLUB	
	<input type="checkbox"/> SOCIAL CLUB	

SPECIAL DESIGNATIONS (CHOOSE ONLY ONE)

GOLF CLUB GUEST RANCH RESORT

To Assist the Liquor Division with scheduling inspections: **OPERATIONAL STATUS**

FULL TIME (e.g. Jan through Dec) (specify months of operation) from Jan to Dec

SEASONAL/PART-TIME DAYS OF WEEK (e.g. Mon through Sat) from Monday to Sunday

NON-OPERATIONAL/PARKED HOURS OF OPERATION (e.g. 10a - 2a) from 11 am to 10 pm

ALL APPLICANTS MUST COMPLETE QUESTIONS 1-4

1. **BUILDING OWNERSHIP:** Does the applicant? W.S. 12-4-103(a)(iii)
- (a) **OWN** the licensed building? YES (own)
 - (b) **LEASE** the licensed building? (Lease must be through the term of the liquor license) YES (lease)

If Yes, please submit a copy of the lease and indicate:

- (i) When the lease expires, located on page 1 paragraph 4 of lease.
- (ii) Where the **Sales** provision for alcoholic or malt beverages is located, on page 1 paragraph 3 of lease.
(MUST contain a provision for SALE OF ALCOHOLIC or MALT BEVERAGES.)

2. To operate your liquor business, have you assigned, leased, transferred or contracted with any other person (entity) to operate and assert total or partial control of the license and the licensed building? W.S. 12-4-601(b) YES NO

3. Does any manufacturer, brewer, rectifier, wholesaler, or through a subsidiary affiliate, officer, director or member of any such firm: W.S. 12-5-401, 12-5-402, 12-5-403
- (a) Hold any interest in the license applied for? YES NO
 - (b) Furnish by way of loan or any other money or financial assistance for purposes hereof in your business? YES NO
 - (c) Furnish, give, rent or loan any equipment, fixtures, interior decorations or signs other than standard brewery or manufacturer's signs? YES NO
 - (d) If you answered **YES** to any of the above, explain fully and submit any documents in connection there within:

4. Does the applicant have any interest or intent to acquire an interest in any other liquor license issued by this licensing authority? W.S. 12-4-103(b) YES NO
If "YES", explain: _____

5. BAR AND GRILL LICENSE OR RESTAURANT LICENSE:

Have you submitted a valid food service permit or application? W.S. 12-4-413(a) YES NO

6. RESORT LICENSE:

Does the resort complex:

- (a) Have an actual valuation of at least one million dollars, or have you committed or expended at least one million dollars (\$1,000,000.00) on the complex, excluding the value of the land? W.S. 12-4-401(b)(i) YES NO
- (b) Include a restaurant and a convention facility which will seat at least one hundred (100) persons? W.S. 12-4-401(b)(ii) YES NO
- (c) Include motel, hotel or privately owned condominium, town house or home accommodations approved for short term occupancy with at least one hundred (100) sleeping rooms? W.S. 12-4-401(b)(iii) YES NO
- (d) If no on question (c), have a ski resort facility open to the general public in which you have committed or expended not less than 10 million dollars (\$10,000,000.00)? W.S. 12-4-401(b)(iv) YES NO
- (e) Are you contracting/leasing the food and beverage services? W.S. 12-4-403(b)
 - 1. If Yes, have you submitted a copy of the food and beverage contract/lease? YES NO

7. MICROBREWERY LICENSE:

- (a) Do you self distribute your products? W.S. 12-2-201(a) YES NO
(Requires wholesale malt beverage license with the Liquor Division)

8. LIMITED RETAIL (CLUB) LICENSE:

FRATERNAL CLUBS W.S. 12-1-101(a)(iii)(B)

- (a) Has the fraternal organization been actively operating in at least thirty-six (36) states? YES NO
- (b) Has the fraternal organization been actively in existence for at least twenty (20) years? YES NO

9. LIMITED RETAIL (CLUB) LICENSE:

VETERANS CLUBS W.S. 12-1-101(a)(iii)(A).

- (a) Does the Veteran's organization hold a charter by the Congress of the United States? YES NO
- (b) Is the membership of the Veteran's organization comprised only of Veterans and its duly organized auxiliary? YES NO

10. LIMITED RETAIL (CLUB) LICENSE:

GOLF CLUBS W.S. 12-1-101(a)(iii)(D)/W.S. 12-4-301(e):

- (a) Do you have more than fifty (50) bona fide members? YES NO
- (b) Do you own, maintain, or operate a bona fide golf course together with clubhouse? YES NO
- (c) Are you a political subdivision of the state that owns, maintains, or operates a golf course? YES NO
 - 1. Are you contracting/leasing the food and beverage services? W.S. 12-5-201(g) YES NO
 - 2. If Yes, have you submitted a copy of the food and beverage contract/lease? YES NO

11. LIMITED RETAIL (CLUB) LICENSE:

SOCIAL CLUBS W.S. 12-1-101(a)(iii)(E)/W.S. 12-4-301(b):

- (a) Do you have more than one hundred (100) bona fide members who are residents of the county in which the club is located? YES NO
- (b) Is the club incorporated and operating solely as a nonprofit organization under the laws of this state? YES NO
- (c) Is the club qualified as a tax exempt organization under the Internal Revenue Service? YES NO
- (d) Has the club been in continuous operation for a period of not less than one (1) year? YES NO
- (e) Has the club received twenty-five dollars (\$25.00) from each bona fide member as Recorded by the secretary of the club and are club members at the time of this application in good standing by having paid at least one (1) full year in dues? YES NO
- (f) Does the club hold quarterly meetings and have an actively engaged membership carrying out the objectives of the club? YES NO
- (g) Have you filed a true copy of your bylaws with this application? YES NO
- (h) Has at least fifty one percent (51%) of the membership signed a petition indicating a desire to secure a Limited Retail Liquor License? (Petition Attached) YES NO

12. If applicant is filing as an Individual, Partnership or Club: W.S. 12-4-102(a)(ii) & (iii)

Each individual, partner or club officer must complete the box below.

True and Correct Name	Date of Birth	Residence Address No. & Street City, State & Zip <i>DO NOT LIST PO BOXES</i>	Residence Phone Number	Have you been a DOMICILED resident for at least 1 year and not claimed residence in any other state in the last year?	Have you been Convicted of a Felony Violation?	Have you been Convicted of a Violation Relating to Alcoholic Liquor or Malt Beverages?
Holden Krai	10/13/88	2330 Mercy Circle Casper WY 82609	307-797-4108	YES <input checked="" type="checkbox"/> NO <input type="checkbox"/>	YES <input type="checkbox"/> NO <input checked="" type="checkbox"/>	YES <input type="checkbox"/> NO <input checked="" type="checkbox"/>
Joe Rosen	05/24/63	4621 E 24th St Casper WY 82609	307-263-4108	YES <input checked="" type="checkbox"/> NO <input type="checkbox"/>	YES <input type="checkbox"/> NO <input checked="" type="checkbox"/>	YES <input type="checkbox"/> NO <input checked="" type="checkbox"/>
Beverly Rosen	11/04/59	4621 E 24th St Casper WY 82609	307-263-4108	YES <input checked="" type="checkbox"/> NO <input type="checkbox"/>	YES <input checked="" type="checkbox"/> NO <input checked="" type="checkbox"/>	YES <input type="checkbox"/> NO <input checked="" type="checkbox"/>
				YES <input type="checkbox"/> NO <input type="checkbox"/>	YES <input type="checkbox"/> NO <input type="checkbox"/>	YES <input type="checkbox"/> NO <input type="checkbox"/>
				YES <input type="checkbox"/> NO <input type="checkbox"/>	YES <input type="checkbox"/> NO <input type="checkbox"/>	YES <input type="checkbox"/> NO <input type="checkbox"/>
				YES <input type="checkbox"/> NO <input type="checkbox"/>	YES <input type="checkbox"/> NO <input type="checkbox"/>	YES <input type="checkbox"/> NO <input type="checkbox"/>
				YES <input type="checkbox"/> NO <input type="checkbox"/>	YES <input type="checkbox"/> NO <input type="checkbox"/>	YES <input type="checkbox"/> NO <input type="checkbox"/>

(If more information is required, list on a separate piece of paper and attach to this application.)

13. If the applicant is a Corporation, Limited Liability Company, Limited Liability Partnership or Limited Partnership: W.S. 12-4-102(a)(iv) & (v)

Each stockholder holding, either jointly or severally, ten percent (10%) or more of the outstanding and issued capital stock of the corporation, limited liability company, limited liability partnership, or limited partnership, and every officer, and every director must complete the box below.

True and Correct Name	Date of Birth	Residence Address No. & Street City, State & Zip <i>DO NOT LIST PO BOXES</i>	Residence Phone Number	No of Years in Corp or LLC	% of Corporate Stock Held	Have you been Convicted of a Felony Violation?	Have you been Convicted of a Violation Relating to Alcoholic Liquor or Malt Beverages?
Holden Kai						YES <input type="checkbox"/> NO <input checked="" type="checkbox"/>	YES <input type="checkbox"/> NO <input checked="" type="checkbox"/>
Joe Rosen						YES <input type="checkbox"/> NO <input checked="" type="checkbox"/>	YES <input type="checkbox"/> NO <input checked="" type="checkbox"/>
Beverly Rosen						YES <input type="checkbox"/> NO <input checked="" type="checkbox"/>	YES <input type="checkbox"/> NO <input checked="" type="checkbox"/>
						YES <input type="checkbox"/> NO <input type="checkbox"/>	YES <input type="checkbox"/> NO <input type="checkbox"/>
						YES <input type="checkbox"/> NO <input type="checkbox"/>	YES <input type="checkbox"/> NO <input type="checkbox"/>
						YES <input type="checkbox"/> NO <input type="checkbox"/>	YES <input type="checkbox"/> NO <input type="checkbox"/>

(If more information is required, list on a separate piece of paper and attach to this application)

REQUIRED ATTACHMENTS:

- A statement indicating the financial condition and financial stability of the applicant. W.S. 12-4-102(a)(vi).
- Attach any lease agreements (especially for resort/political subdivisions leasing out food & beverage services) W.S. 12-4-103 (a)(iii)/W.S. 12-4-403(b) / W.S. 12-4-301(e).
- If transferring a license from one ownership to another, a form of assignment from the current licensee to the new applicant authorizing the transfer. W.S. 12-4-601(b).

OATH OR VERIFICATION

(Requires signatures by ALL Individuals, ALL Partners, ONE (1) LLC Member, or TWO (2) Corporate Officers or Directors except that if all the stock of the corporation is owned by ONE (1) individual then that individual may sign and verify the application upon his oath, or TWO (2) Club Officers.) W.S. 12-4-102(b)

Under penalty of perjury, and the possible revocation or cancellation of the license, I swear the above stated facts, are true and accurate.

STATE OF WYOMING)
COUNTY OF Natrona) SS.

Signed and sworn to before me on this 5th day of April, 2023 that the facts alleged in the foregoing instrument are true by the following:

- | | | |
|--------------------------------------|--|---------------------------------|
| 1) <u>[Signature]</u>
(Signature) | <u>Holden Kai</u>
(Printed Name) | <u>Managing Member</u>
Title |
| 2) <u>[Signature]</u>
(Signature) | <u>J. Rosen</u>
(Printed Name) | <u>Member</u>
Title |
| 3) <u>[Signature]</u>
(Signature) | <u>Beverly Rosen</u>
(Printed Name) | <u>Member</u>
Title |
| 4) _____
(Signature) | _____
(Printed Name) | _____
Title |
| 5) _____
(Signature) | _____
(Printed Name) | _____
Title |
| 6) _____
(Signature) | _____
(Printed Name) | _____
Title |

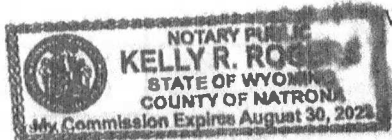

Witness my hand and official seal: [Signature]
Signature of Notary Public
My commission expires: Aug 30, 2023

AFFIDAVIT OF WEBSITE PUBLICATION

State of Wyoming)
County of Natrona)

I, the undersigned, being in the employ of the City of Casper and responsible for the publishing and posting of notices for the Casper City Council's public hearings concerning liquor licensing, and knowing the facts herein set forth do solemnly swear that:

- Notice of the public hearing set forth below was posted continually on the City of Casper website in accordance with W.S. 12-4-104. The said posting commenced on 04/18/2023 and ended on 05/03/2023 and
- Attached is image of the Notice as actually posted on the City of Casper website (www.caserwy.gov) for the entire period referenced above.

By: Carla Mills Laatsch

Date: 4/25/2023

Title: Licensing Specialist

Scribed in my presence and sworn before me on this

25th day of April, 2023

[Signature]

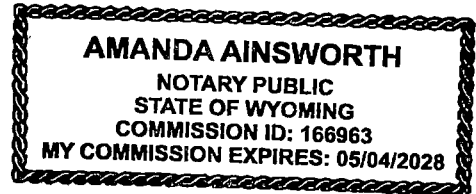

Provide to City of Casper Central Records

TRANSFER OF OWNERSHIP FOR RETAIL LIQUOR LICENSE

An application for transfer of ownership for retail liquor license no. 37 Bull Horn Brewing, LLC dba Bull Horn Brewing, located at 355 West Yellowstone has been received in this office. Public Hearing on said application will be held on May 2, 2023, at 6:00 p.m. in the City Council Chambers at 200 North David, Casper, Wyoming.



Fleur Tremel
City Clerk

Publish: April 19 & April 23, 2023

ORDINANCE NO. 6-23

AN ORDINANCE CREATING CITY OF CASPER, WYOMING, LOCAL ASSESSMENT DISTRICT NO. 159 (HEREINAFTER CALLED THE "DISTRICT"); ORDERING THE CONSTRUCTION OF IMPROVEMENTS THEREIN; DESCRIBING THE SAME, DIRECTING THE PREPARATION OF PLANS AND SPECIFICATIONS THEREFOR; PROVIDING FOR THE PUBLICATION OF NOTICE TO CONTRACTORS; FIXING THE BOUNDARIES OF SAID DISTRICT; RATIFYING ACTION PREVIOUSLY TAKEN; AND, PRESCRIBING DETAILS IN CONNECTION WITH SAID DISTRICT.

WHEREAS, pursuant to Title 15, Chapter 6, Wyoming Statutes, 1977, as amended, on the 7th day of March, 2023, the City Council (hereinafter called the "Council") of the City of Casper, Wyoming, (hereinafter called the "City") adopted a Resolution No. 23-37 declaring the intention of said Council to establish the City of Casper, Wyoming, Local Assessment District No. 159, to authorize the construction of certain local improvements therein, and to assess the cost or portion thereof of the local improvements on the property benefited thereby; and,

WHEREAS, said Resolution was duly mailed and published as a notice, affidavits of such mailing and publication being now on file in the Office of the City Clerk; and,

WHEREAS, in response to said notice, no written remonstrances were filed against the proposed improvements; and,

WHEREAS, a public hearing shall be held on the first reading of this Ordinance, April 18, 2023.

NOW, THEREFORE, BE IT ORDAINED BY THE GOVERNING BODY OF THE CITY OF CASPER, WYOMING:

Section 1. Creation of District.

That there be, and there hereby is created and established within the corporate limits of the City of Casper, Wyoming, a local improvement district for the purpose of making certain local improvements consisting of asphaltic concrete pavement, concrete curbwalk, water main, sanitary sewer, storm sewer improvements and work incidental thereto, on the streets and intersections hereinafter designated and to assess the cost thereof on the property benefitted thereby and included within the proposed local assessment district herein described.

Section 2. Name of District; Combination of Improvements.

The Council has determined and does hereby determine that:

- A. The local assessment district herein described, as such might hereinafter be modified, shall be known as the "City of Casper, Wyoming, Local Assessment District No. 159, Westridge Improvements" (herein called the "District");
- B. More than one improvement shall be combined in the District as the combination of improvements hereafter described is both efficient and economical; and,
- C. As certain improvements are separate and distinct by reason of a substantial difference in character, location, method of assessment, and otherwise, the estimated costs thereof shall be segregated for the levy of assessments and an equitable share of the incidental costs shall be allocated to each improvement. For this purpose, the following improvements are hereby recognized as separate and distinct.
 - 1. Concrete curbwalk
 - 2. Sanitary sewer

Section 3. Location of Improvements.

The City proposes to establish grades for the following named streets, intersections, and parts of streets, within the City between the termini specified, as such are set forth on the official plats of the subdivisions or additions in said City, now on file and of record, as follows:

LOCATION OF WESTRIDGE IMPROVMENTS

STREET	PROPOSED IMPROVEMENT
1. Westridge Circle	concrete curbwalk, sanitary sewer service
2. Westridge Drive	concrete curbwalk, sanitary sewer service
3. Westridge Terrace	concrete curbwalk, sanitary sewer service
4. Westwood Hill	concrete curbwalk

Section 4. Description of Improvements.

- A. The character, kind, and extent of the concrete curbwalk improvements shall be as follows:
 - 1. All curbwalk as denoted in Section 3 shall include reconditioning of existing sub-base aggregate base course, and installation of a plant mix concrete in accordance with approved City Standards. The work shall include all necessary removal, excavation, filling, grading, and replacement to design elevations and appurtenant work.

- B. The character, kind, and extent of the sanitary sewer service improvements shall be as follows:
 - 1. All sanitary sewer as denoted in Section 3 shall be installed in accordance with approved City Standards. The work shall include all necessary removal, excavation, pipe service work from main to property line, filling, grading, and replacement to design elevations and appurtenant work.

Section 5. Boundaries of the District.

It is proposed to create the District, the boundaries of which lie entirely within the City of Casper, as follows:

Westridge Addition	Lots 86-180
Westwood No. 3 Addition	Lots 617-627

Section 6. Determination of Benefits.

The City Council has determined, and does hereby determine, that the method of assessment will result in a distribution of costs among property owners in proportion to the special benefits conferred by the improvements, and that any other method of assessment would result in an inequitable distribution of costs among some owners whose property is benefitted by the improvements.

Section 7. Method of Assessment.

- A. Improvements. Each piece of property along which the improvements are to be made shall be assessed by the following method:
 - 1. Each property shall be assessed on the basis of its lineal footage of concrete curbwalk fronting its street with the longest side of corner lots and intersection radii being distributed equally to each assessed property. Costs for sanitary sewer services are based on lineal footage of service pipe replaced and assessed only to those properties with sanitary sewer services in need of replacement.
- B. Assessment Liens. Notwithstanding any provision to the contrary, the assessment shall be levied and an assessment lien attached on all, or a piece, of benefitted property so as to avoid the imposition of a lien upon a part of the subdivided lot or partial lot under common ownership and use.

Section 8. Estimated Costs.

The City of Casper has hired WLC Engineering and Surveying to develop plans for the proposed improvements in the Westridge Area, prepare a detailed cost estimate, and to assist in forming an LAD. The construction of the improvements will be performed by a qualified contractor with the

lowest competitive bid. The properties will be assessed the full cost for a contractor to install the improvements, plus the cost of engineering.

The estimated total costs for the total improvement project (including, but not limited to, all incidental improvements or work) are as follows:

1. The estimated contract price for sanitary sewer service improvements is \$ 48,100.
2. The estimated contract price for concrete curbwalk improvements is \$ 546,975.
3. The estimated price for engineering is \$ 89,261.25
4. The estimated total cost of the total improvement project is \$ 684,336.25.
5. The estimated assessable cost for each lineal foot of concrete curbwalk for each property is as follows:
 - a. \$74.75 per lineal foot.
6. The estimated assessable cost for each lineal foot of sanitary sewer service for each property to be benefited is as follows:
 - a. \$57.50 per lineal foot.

The City's funding source will be from 1%#16 funds for Westridge Improvements.

The City Council shall accept no bids or combination of bids, which shall exceed by more than ten percent (10%) the aforesaid estimate of the contract price unless approved by the property owners, subject to a special assessment.

Section 9. Direction to Engineer to Proceed.

The City Engineer is hereby directed and authorized, immediately upon the passage of this Ordinance, to prepare and file with the City Clerk final plans, specifications, and the estimated cost of said improvements, which plans, specifications, and estimated cost shall show in detail the work to be done, the quantities of materials to be handled and the estimated cost of said improvements, which plans, specifications, and estimated cost shall be hereafter approved by the Council, by resolution.

It is hereby determined and ordered, that such improvements shall be made as soon as practical. Immediately after the approval of said plans and specifications, the City Clerk shall call for bids for the making of said improvements, by publishing notice in at least one issue of a newspaper published and of general circulation within the City of Casper, which notice shall be substantially in agreement with the provisions of Wyoming Statutes, 1977, as amended, and this Ordinance.

Section 10. Maintenance of Improvements.

The maintenance of the proposed improvements after their acceptance by the City on said streets, intersections, and parts thereof, shall not be included in the construction contract or contracts, and there shall be no charges for such maintenance included in the assessments for the proposed improvements; provided, however, that nothing herein shall be construed to preclude provision in the contract or contracts relating to the guarantee of improvements thereunder.

Section 11. Ratification.

All action heretofore taken by the City and officers thereof, directed toward the creation of the City of Casper, Wyoming, Local Assessment District No. 159, the improvement of property therein and the levy of assessments therefor, be, and the same hereby is, ratified, approved, and confirmed.

Section 12. Severability.

If any section, paragraph, clause, or provision of this Ordinance shall for any reason be held to be invalid or unenforceable, the invalidity or unenforceability of such section, paragraph, clause, or provision shall not affect any of the remaining provisions of this Ordinance.

Section 13. Repealer.

All orders, bylaws, resolutions, and ordinances, or parts thereof, in conflict with this Ordinance are hereby repealed to the extent of such inconsistency.

(this space intentionally left blank)

Section 14. Authorization of Officers and Employees.

The officers and employees of the City are hereby authorized and directed to take all action necessary and appropriate to effectuate the provisions of this Ordinance.

PASSED on 1st reading the 18th day of April, 2023.

PASSED on 2nd reading the ____ day of _____, 2023.

PASSED, APPROVED, AND ADOPTED on 3rd and final reading the ____ day of _____, 2023.

APPROVED AS TO FORM:

Eric K. Veln

ATTEST:

CITY OF CASPER, WYOMING
A Municipal Corporation

Fleur Tremel
City Clerk

Bruce Knell
Mayor

WESTRIDGE PHASE 1 OWNERSHIP AND ASSESSMENT ROLE

Prepared by W.C. Engineering and Surveying, Updated February 2, 2023

NOTE



Indicates Corner Lot
Change of Owner or Address Since Beginning

Owner 1	Street Address	Mailing Address	City, State, Zip	Lot Size (acres)	Legal	Street Frontage (ft)	Corner Frontage (ft)	Curve Frontage (ft)	Street Frontage for Assessment (ft)	Estimated Assessment for Curbwalk (\$)	Estimated Sewer Service Length (ft)	Estimated Sewer Services Cost (\$)	Total Estimated Assessment (\$)	Estimated Annual Assessment at 3% for 10 Years (\$)
118 HOLDINGS, LLC	2008 CY AVE	6758 WHISKEY GAP ROAD	CASPER, WY 82604	0.466	627 SUBDIVISION TRACT C	81.5	125.5	105.7	79.40	\$4,900.81	46.00	\$2,250.00	\$6,052.52	\$944.00
ADAMS HRP A	1752 WESTRIDGE CIR	1752 WESTRIDGE CIR	CASPER, WY 82604	0.168	WESTRIDGE LOT 169	61			74.50	\$4,868.31	15.00	\$750.00	\$6,326.77	\$741.69
ALLEN DONALD F ET UX	1664 WESTRIDGE DR	PO BOX 1233	CASPER, WY 82602	0.152	WESTRIDGE LOT 112	57.1			71.00	\$4,614.81			\$5,196.73	\$609.22
BEARD CHRISTOPHER ET UX	1694 WESTRIDGE CIR	1694 WESTRIDGE CIR	CASPER, WY 82604	0.439	WESTRIDGE LOT 163	47			60.90	\$3,958.31	40.00	\$2,000.00	\$6,706.65	\$786.56
BECKTON WILLIAM C ET UX	1745 WESTRIDGE DR	1745 WESTRIDGE DR	CASPER, WY 82604	0.160	WESTRIDGE LOT 102	61.8			75.70	\$4,920.31			\$5,540.76	\$649.55
BERGMAN STEPHEN M ET UX	1652 WESTRIDGE CIR	1652 WESTRIDGE CIR	CASPER, WY 82604	0.165	WESTRIDGE LOT 158	60			73.90	\$4,803.31	16.00	\$800.00	\$6,309.88	\$739.71
BERNARD MIQUELLE	1704 WESTRIDGE DR	1704 WESTRIDGE DR	CASPER, WY 82604	0.175	WESTRIDGE LOT 119	57.1			71.00	\$4,614.81			\$5,196.73	\$609.22
BERTAG PROPERTIES LLC	2000 WESTWOOD HILL	BOX 502	WILLS, WY 82644	0.336	WESTWOOD #3 LOT 822 COMMERCIAL	68.5			82.40	\$5,355.81			\$6,031.17	\$707.04
BERTAGNOLE BRYAN ET UX	2014 WESTWOOD HILL	BOX 502	WILLS, WY 82644	0.239	WESTWOOD #3 LOT 821 COMMERCIAL	79.5			93.40	\$6,070.81			\$6,836.33	\$801.43
BERTZ DONNA K	1644 WESTRIDGE CIR	1644 WESTRIDGE CIR	CASPER, WY 82604	0.165	WESTRIDGE LOT 157	60			73.50	\$4,803.31	16.00	\$800.00	\$6,306.88	\$739.71
BLACK TERIL E ET VIR	1712 WESTRIDGE CIR	1712 WESTRIDGE CIR	CASPER, WY 82604	0.168	WESTRIDGE LOT 165	61			74.50	\$4,868.31	16.00	\$800.00	\$6,383.08	\$748.29
BLAZEK-SEVERANCE CYNTHIA L ET VIR	1657 WESTRIDGE CIR	1657 WESTRIDGE CIR	CASPER, WY 82604	0.176	WESTRIDGE LOT 149	63.8			77.70	\$5,050.31	35.00	\$1,750.00	\$7,657.82	\$897.73
BOYLES VELMA NAY	1534 WESTRIDGE DR	1534 WESTRIDGE DR	CASPER, WY 82604	0.143	WESTRIDGE LOT 108	55			68.90	\$4,478.31			\$5,043.02	\$591.20
BROADSHAW ROBERT E ET AL TRUSTEES	1522 WESTRIDGE TER	PO BOX 1838	WILLS, WY 82644	0.260	WESTRIDGE LOT 152	60			73.90	\$4,803.31	15.00	\$750.00	\$6,253.56	\$733.11
BRENNAN BOBETTE L	1704 WESTRIDGE CIR	1704 WESTRIDGE CIR	CASPER, WY 82604	0.291	WESTRIDGE LOT 164	47			60.90	\$3,958.31	30.00	\$1,500.00	\$6,146.60	\$720.57
BRENTON FAMILY INVESTMENTS LLC	NA	PO BOX 50127	CASPER, WY 82605	0.307	627 SUBDIVISION TRACT B	61			74.90	\$4,868.31			\$5,482.20	\$642.68
BRENTON FAMILY INVESTMENTS, LLC	1944 CY AVE	PO BOX 50127	CASPER, WY 82605	0.507	627 SUBDIVISION TRACT A	170.4		156.5	184.30	\$11,978.31	32.00	\$1,600.00	\$15,281.66	\$1,782.86
BUFF JAMES E ET UX	1617 WESTRIDGE TER	1617 WESTRIDGE TER	CASPER, WY 82604	0.196	WESTRIDGE LOT 132	58			71.50	\$4,673.31			\$5,262.61	\$616.94
CAMP PROPERTIES LLC	1814 WESTRIDGE CIR	PO BOX 52271	CASPER, WY 82605	0.168	WESTRIDGE LOT 171	61			74.90	\$4,868.31	15.00	\$750.00	\$6,326.77	\$741.69
CARLSON CAPP A ET UX	1514 WESTRIDGE DR	PO BOX 1466	CASPER, WY 82602	0.143	WESTRIDGE LOT 107	55			68.90	\$4,478.31			\$5,043.02	\$591.20
CESTNIK CHAD S	1524 WESTRIDGE DR	1524 WESTRIDGE DR	CASPER, WY 82604	0.143	WESTRIDGE LOT 108	55			68.90	\$4,478.31			\$5,043.02	\$591.20
CHAMPENDAL JACQUELINE	1667 WESTRIDGE CIR	1667 WESTRIDGE CIR	CASPER, WY 82604	0.200	WESTRIDGE LOT 146	74			87.90	\$5,713.31	35.00	\$1,750.00	\$8,404.43	\$985.26
CURTIS RICHARD L ET UX	1504 WESTRIDGE DR	1504 WESTRIDGE DR	CASPER, WY 82604	0.158	WESTRIDGE LOT 106	60		4.3	73.90	\$4,803.31			\$5,408.00	\$634.10
DEPAOLO LARA FAMILY LIVING TRUST 1/28/2015	1535 WESTRIDGE DR	4921 S ELM ST	CASPER, WY 82601	0.143	WESTRIDGE LOT 89	55			68.90	\$4,478.31			\$5,043.02	\$591.20
DIORIO JOHN N TRUSTEE	1683 WESTRIDGE TER	2320 RIVER MEADOWS RD	CASPER, WY 82604	0.280	WESTRIDGE LOT 125	87.2	88	13.68	101.10	\$6,571.31			\$7,389.95	\$887.50
DISTAD INGER LOUISE ET AL	1684 WESTRIDGE CIR	1684 WESTRIDGE CIR	CASPER, WY 82604	0.274	WESTRIDGE LOT 162	47			60.90	\$3,958.31	35.00	\$1,750.00	\$6,428.12	\$753.57
DRURY DALE EARL	1827 WESTRIDGE CIR	1827 WESTRIDGE CIR	CASPER, WY 82604	0.195	WESTRIDGE LOT 124	60			73.90	\$4,803.31			\$5,409.00	\$634.10
ELIZABETH J MUNN REVOCABLE TRUST 5/25/2003	1525 WESTRIDGE DR	PO BOX 50741	CASPER, WY 82605	0.143	WESTRIDGE LOT 88	55			68.90	\$4,478.31			\$5,043.02	\$591.20
ELLIOTT RANDY L	1705 WESTRIDGE DR	1705 WESTRIDGE DR	CASPER, WY 82604	0.160	WESTRIDGE LOT 98	61.8			75.70	\$4,920.31			\$5,540.76	\$649.55
FARRIS MARSHALL	1647 WESTRIDGE TER	1647 WESTRIDGE TER	CASPER, WY 82604	0.196	WESTRIDGE LOT 129	58			71.50	\$4,673.31			\$5,262.61	\$616.94
FBS CASPER LLC	2004 CY AVE	PO BOX 50127 CASPER WY 82605	CASPER, WY 82605	0.230	WESTWOOD #3 LOT 817 COMMERCIAL	80		18	93.90	\$6,103.31			\$6,872.93	\$805.72
FOSTER JUSTIN W	1436 W 15TH ST	1436 W 15TH ST	CASPER, WY 82604	0.156	WESTRIDGE LOT 88	60		3.25	73.90	\$4,803.31			\$5,408.00	\$634.10
FRISBY ROBYN H	1642 WESTRIDGE DR	1642 WESTRIDGE DRIVE	CASPER, WY 82604	0.173	WESTRIDGE LOT 116	57.1			71.00	\$4,614.81			\$5,196.73	\$609.22
GARNER BRANDON ET UX	1775 WESTRIDGE DR	1775 WESTRIDGE DR	CASPER, WY 82604	0.156	WESTRIDGE LOT 105	60			73.90	\$4,803.31			\$5,409.00	\$634.10
GARRISON OTIS M	1660 WESTRIDGE CIR	5374 S QUATAR CIR	AURORA CO 80015	0.165	WESTRIDGE LOT 159	60			73.90	\$4,803.31	16.00	\$800.00	\$6,309.88	\$739.71
GAY WILMER III ET UX	1745 WESTRIDGE CIR	1745 WESTRIDGE CIR	CASPER, WY 82604	0.270	WESTRIDGE LOT 144	99	154	15	112.90	\$7,338.31	35.00	\$1,750.00	\$10,234.34	\$1,198.78

Owner 1	Street Address	Mailing Address	City, State, Zip	Lot Size (acres)	Legal	Street Frontage (ft)	Corner Frontage (ft)	Curve Frontage (ft)	Street Frontage for Assessment (ft)	Estimated Assessment for Curbwalk (\$)	Estimated Sewer Service Length (ft)	Estimated Sewer Services Cost (\$)	Total Estimated Assessment (\$)	Estimated Annual Assessment at 3% for 10 Years (\$)
OLYNN DOROTHY ET AL	1742 WESTRIDGE CIR	1742 WESTRIDGE CIR	CASPER, WY 82604	0.168	WESTRIDGE LOT 168	61			74.90	\$4,868.31	15.00	\$750.00	\$6,326.77	\$741.69
GREENLINE PROPERTIES LLC-SERIES B	1683 WESTRIDGE TER	7230 ROCKING R RD	CASPER, WY 82604	0.196	WESTRIDGE LOT 127	58			71.90	\$4,673.31			\$5,262.61	\$616.94
GRIMSHAW INVESTMENTS LLC	1851 WESTRIDGE CIR	39 E 1ST ST	SHERIDAN, WY 82601	0.162	WESTRIDGE LOT 122	115			128.90	\$8,378.31			\$9,434.61	\$1,108.05
HACKETT JOAN R	1625 WESTRIDGE DR	1625 WESTRIDGE DR	CASPER, WY 82604	0.160	WESTRIDGE LOT 94	61.8			75.70	\$4,920.31			\$5,540.76	\$649.55
HARTMANN LYLE	1521 WESTRIDGE TER	1521 WESTRIDGE TERR	CASPER, WY 82604	0.143	WESTRIDGE LOT 137	55			68.90	\$4,478.31			\$5,043.02	\$591.20
HASOJET ARRETIA A	1638 WESTRIDGE TER	1638 WESTRIDGE TER	CASPER, WY 82604	0.153	WESTRIDGE LOT 142	60			73.90	\$4,803.31	15.00	\$750.00	\$6,253.58	\$733.11
HEATON LAURIE L	1668 WESTRIDGE CIR	1668 WESTRIDGE CIR	CASPER, WY 82604	0.165	WESTRIDGE LOT 160	60			73.90	\$4,803.31	16.00	\$800.00	\$6,309.88	\$739.71
HOUSEZ LLC	1837 WESTRIDGE CIR	1888 BRYAN STOCK TRL	CASPER, WY 82601	0.180	WESTRIDGE LOT 123	60			73.90	\$4,803.31			\$5,409.00	\$634.10
HUBBARD DENISE A ET VIR	1614 WESTRIDGE CIR	1614 WESTRIDGE CIR	CASPER, WY 82604	0.259	WESTRIDGE LOT 154	53.5			67.40	\$4,380.81	35.00	\$1,750.00	\$6,903.90	\$809.35
HURT LUCAS ET UX	1721 WESTRIDGE CIR	1721 WESTRIDGE CIR	CASPER, WY 82604	0.158	WESTRIDGE LOT 146	60			73.90	\$4,803.31	35.00	\$1,750.00	\$7,379.68	\$885.12
JAMES & SUZANNE FELTEN LIVING	1548 WESTRIDGE TER	1548 WESTRIDGE TR	CASPER, WY 82604	0.206	WESTRIDGE LOT 143	81.7			95.60	\$6,213.61	15.00	\$750.00	\$7,841.94	\$919.31
JOANNE DEMOREST LIVING TRUST 10/24/2014	1716 WESTRIDGE DR	1219 S WOLCOTT ST	CASPER, WY 82601	0.165	WESTRIDGE LOT 120	60			73.90	\$4,803.31			\$5,409.00	\$634.10
JOHNSON GWEN	1832 WESTRIDGE CIR	1219 S WOLCOTT ST	CASPER, WY 82601	0.168	WESTRIDGE LOT 173	61			74.90	\$4,868.31	15.00	\$750.00	\$6,326.77	\$741.69
KAY E BRITANN TRUST 12/14/98	1715 WESTRIDGE DR	1515 W 12TH ST	CASPER, WY 82604	0.160	WESTRIDGE LOT 99	61.8			75.70	\$4,920.31			\$5,540.76	\$649.55
KENNEDY ADAM J	1537 WESTRIDGE TER	1537 WESTRIDGE TER	CASPER, WY 82604	0.143	WESTRIDGE LOT 135	55			68.90	\$4,478.31			\$5,043.02	\$591.20
KINION BRETT	1772 WESTRIDGE DR	1772 WESTRIDGE DR	CASPER, WY 82604	0.234	WESTRIDGE LOT 178	90		1.15	103.80	\$6,783.31			\$7,804.90	\$881.53
KRAMER WILLIAM M JR	1735 WESTRIDGE DR	1735 WESTRIDGE DR	CASPER, WY 82604	0.160	WESTRIDGE LOT 101	61.8			75.70	\$4,920.31			\$5,540.76	\$649.55
LADWIG JESSICA	1725 WESTRIDGE DR	1725 WESTRIDGE DR	CASPER, WY 82604	0.160	WESTRIDGE LOT 100	61.8			75.70	\$4,920.31			\$5,540.76	\$649.55
LAI FAMILY LLC	2034 WESTWOOD HILL	BOX 577	CASPER, WY 82602	0.344	WESTWOOD #3 LOT 819 COMMERCIAL	68.5			82.40	\$5,355.81			\$6,031.17	\$707.04
LAI FAMILY LLC	2024 WESTWOOD HILL	BOX 577	CASPER, WY 82602	0.239	WESTWOOD #3 LOT 820 COMMERCIAL	79.5			93.40	\$6,070.81			\$6,836.33	\$801.43
LARSON MARK T	1505 WESTRIDGE TER	1505 WESTRIDGE TER	CASPER, WY 82604	0.156	WESTRIDGE LOT 139	60			73.90	\$4,803.31			\$5,409.00	\$634.10
LEONHARDT BRYCE PAUL ET UX	1733 WESTRIDGE CIR	1733 WESTRIDGE CIR	CASPER, WY 82604	0.158	WESTRIDGE LOT 145	60			73.90	\$4,803.31	35.00	\$1,750.00	\$7,379.68	\$885.12
LEWIS JOHN F ET AL TRUSTEES	1887 WESTRIDGE CIR	1887 WESTRIDGE CIR	CASPER, WY 82604	0.217	WESTRIDGE LOT 121	81.2	121	15	95.10	\$6,181.31			\$6,980.77	\$816.01
LINOBERG LLC	1634 WESTRIDGE DR	1634 WESTRIDGE DR	CASPER, WY 82604	0.162	WESTRIDGE LOT 115	57.1			71.00	\$4,614.81			\$5,196.73	\$609.22
LOOMER CHERYL D	1607 WESTRIDGE TER	1607 WESTRIDGE TR	CASPER, WY 82604	0.151	WESTRIDGE LOT 133	58			71.90	\$4,673.31			\$5,262.61	\$616.94
REAL ESTATE INVESTMENT LLC	1545 WESTRIDGE DR	1818 E 2ND STREET	CASPER, WY 82601	0.156	WESTRIDGE LOT 104	60			73.90	\$4,803.31			\$5,409.00	\$634.10
REAL ESTATE INVESTMENT LLC	1545 WESTRIDGE DR	1818 E 2ND STREET	CASPER, WY 82601	0.143	WESTRIDGE LOT 90	55			68.90	\$4,478.31			\$5,043.02	\$591.20
LYE ADAM T ET AL	1634 WESTRIDGE CIR	1634 WESTRIDGE CIR	CASPER, WY 82604	0.224	WESTRIDGE LOT 156	56.5			70.40	\$4,575.81	26.00	\$1,300.00	\$6,616.74	\$775.66
MALANDRINI DENNIS E	1624 WESTRIDGE DR	1624 WESTRIDGE DR	CASPER, WY 82604	0.157	WESTRIDGE LOT 114	57.1			71.00	\$4,614.81			\$5,196.73	\$609.22
MC ALLAY ROSE M	1614 WESTRIDGE DR	1723 S WALNUT ST	CASPER, WY 82601	0.155	WESTRIDGE LOT 113	57.1			71.00	\$4,614.81			\$5,196.73	\$609.22
MC CANN CAROL ANN	1615 WESTRIDGE DR	1615 WESTRIDGE DR	CASPER, WY 82604	0.160	WESTRIDGE LOT 93	61.8			75.70	\$4,920.31			\$5,540.76	\$649.55
MC MURRAY JOSEPH R ET AL	1641 WESTRIDGE CIR	1641 WESTRIDGE CIR	CASPER, WY 82604	0.209	WESTRIDGE LOT 150	97.5			111.40	\$7,240.81	35.00	\$1,750.00	\$10,124.55	\$1,188.91
MC QUEEN MARTIN A	1755 WESTRIDGE DR	1755 WESTRIDGE DR	CASPER, WY 82604	0.157	WESTRIDGE LOT 103	60.5			74.40	\$4,835.81			\$5,445.80	\$638.39
MCGOWEN KAGEN	1605 WESTRIDGE DR	1605 WESTRIDGE DR	CASPER, WY 82604	0.160	WESTRIDGE LOT 92	61.8			75.70	\$4,920.31			\$5,540.76	\$649.55
NEEBS LLC	1655 WESTRIDGE DR	710 LA HACIENDA	CASPER, WY 82601	0.160	WESTRIDGE LOT 97	61.8			75.70	\$4,920.31			\$5,540.76	\$649.55
MICHAEL P CORYELL LIVING TRUST 9/8/2022	1854 WESTRIDGE CIR	1854 WESTRIDGE CIR	CASPER, WY 82604	0.302	WESTRIDGE LOT 176	45			58.90	\$3,828.31			\$4,311.05	\$505.36
MIQUEL JOE G SAN JR	1804 WESTRIDGE CIR	1804 WESTRIDGE CIR	CASPER, WY 82604	0.158	WESTRIDGE LOT 170	61			74.90	\$4,868.31	15.00	\$750.00	\$6,326.77	\$741.69
WILLER CARRIE E	1762 WESTRIDGE DR	1762 WESTRIDGE DR	CASPER, WY 82604	0.249	WESTRIDGE LOT 178	58.5			72.40	\$4,705.81			\$5,299.21	\$621.23
MILLVIEW INVESTMENT CO LLC	1956 WESTWOOD HILL	BOX 502	MILLS, WY 82644	0.413	WESTWOOD #3 LOT 823	68.5			82.40	\$5,355.81	18.00	\$900.00	\$7,044.66	\$825.85
MILLVIEW INVESTMENT CO LLC	1945 WESTWOOD HILL	BOX 502	MILLS, WY 82644	0.413	WESTWOOD #3 LOT 824 COMMERCIAL	71.72			85.82	\$5,585.11	18.00	\$900.00	\$7,280.38	\$853.48
MONFRE BARBARA	1527 WESTRIDGE TER	1527 WESTRIDGE TERRACE	CASPER, WY 82604	0.143	WESTRIDGE LOT 136	55			68.90	\$4,478.31			\$5,043.02	\$591.20

Owner 1	Street Address	Mailing Address	City, State, Zip	Lot Size (acres)	Legal	Street Frontage (ft)	Corner Frontage (ft)	Curve Frontage (ft)	Street Frontage for Assessment (ft)	Estimated Assessment for Curbwalk (\$)	Estimated Sewer Service Length (ft)	Estimated Sewer Services Cost (\$)	Total Estimated Assessment (\$)	Estimated Annual Assessment at 3% for 10 Years (\$)
MORTGAGE NOW LLC	1840 WESTRIDGE CIR	2071 W 39TH ST	CASPER, WY 82604	0.184	WESTRIDGE LOT 174	45			58.90	\$3,828.31	15.00	\$750.00	\$5,155.63	\$604.40
MOUNTAIN WEST PROPERTY LEASING LLC	1935 WESTWOOD HILL	4113 W YELLOWSTONE HWY	CASPER, WY 82604	0.290	WESTWOOD #3 LOT 625 COMMERCIAL	90.4			104.30	\$8,779.31	15.00	\$750.00	\$9,478.75	\$993.97
MOUNTAIN WEST PROPERTY LEASING LLC	1924 CY AVE	4113 W YELLOWSTONE HWY	CASPER, WY 82604	0.318	WESTWOOD #3 LOT 626 COMMERCIAL	80		26.6	93.90	\$8,103.31	15.00	\$750.00	\$7,717.51	\$904.73
MORCROSS LOPIR	1676 WESTRIDGE CIR	1676 WESTRIDGE CIR	CASPER, WY 82604	0.223	WESTRIDGE LOT 161	63.5			77.40	\$5,030.61	16.00	\$900.00	\$6,566.07	\$769.74
NORTHROP BRIAN G	1635 WESTRIDGE TER	1635 WESTRIDGE TER	CASPER, WY 82604	0.196	WESTRIDGE LOT 130	58			71.90	\$4,673.31			\$5,262.61	\$616.94
O'GRADY JAMES E	1554 WESTRIDGE DR	1554 WESTRIDGE DR	CASPER, WY 82604	0.143	WESTRIDGE LOT 111	55			68.90	\$4,478.31			\$5,043.02	\$591.20
OSWALD TYSON ET UX	1655 WESTRIDGE TER	1655 WESTRIDGE TER	CASPER, WY 82604	0.196	WESTRIDGE LOT 128	58			71.90	\$4,673.31			\$5,262.61	\$616.94
PAULSON, ERIC DANIEL	1732 WESTRIDGE CIR	1732 WESTRIDGE CIR	CASPER, WY 82604	0.168	WESTRIDGE LOT 167	61			74.90	\$4,868.31	15.00	\$750.00	\$6,328.77	\$741.69
PHILIP S JOHNSTON & DONNA V JOHNSTON TR	1513 WESTRIDGE TER	1513 WESTRIDGE TR	CASPER, WY 82604	0.143	WESTRIDGE LOT 138	55			68.90	\$4,478.31			\$5,043.02	\$591.20
REFKE JOHN D	1824 WESTRIDGE CIR	80X 52038	CASPER, WY 82605	0.168	WESTRIDGE LOT 172	61			74.90	\$4,868.31	15.00	\$750.00	\$6,328.77	\$741.69
ROOT CLEMENT W JR	1545 WESTRIDGE TER	1545 WESTRIDGE TER	CASPER, WY 82604	0.143	WESTRIDGE LOT 134	55			68.90	\$4,478.31			\$5,043.02	\$591.20
ROSENDF, THOMAS ALLEN ET UX	1808 WESTRIDGE TER	1808 WESTRIDGE TER	CASPER, WY 82604	0.290	WESTRIDGE LOT 140	124	182	17.6	137.80	\$9,983.31	15.00	\$750.00	\$10,938.15	\$1,282.29
RUDE RYAN	1656 WESTRIDGE DR	1656 WESTRIDGE DR	CASPER, WY 82604	0.210	WESTRIDGE LOT 118	57.1			71.00	\$4,614.81			\$5,196.73	\$609.22
RUBBELL TIMOTHY O ET UX	1804 WESTRIDGE CIR	1804 WESTRIDGE CIR	CASPER, WY 82604	0.218	WESTRIDGE LOT 153	58.5	119.5	18.8	70.40	\$4,575.81	32.00	\$1,800.00	\$6,954.57	\$815.28
SALZ, SUE E	1510 WESTRIDGE TER	1510 WESTRIDGE TR	CASPER, WY 82604	0.354	WESTRIDGE LOT 151	120			133.90	\$8,703.31	15.00	\$750.00	\$10,645.37	\$1,247.98
SCHAFFER TIMOTHY J	1625 WESTRIDGE TER	1625 WESTRIDGE TER	CASPER, WY 82604	0.196	WESTRIDGE LOT 131	58			71.90	\$4,673.31			\$5,262.61	\$616.94
SHORT FRANCIS M	1635 WESTRIDGE DR	2215 E 27TH ST #18	CASPER, WY 82609	0.160	WESTRIDGE LOT 95	61.8			75.70	\$4,920.31			\$5,540.76	\$649.55
SIMMONS JAMES J ET UX	1624 WESTRIDGE CIR	1624 WESTRIDGE CIR	CASPER, WY 82604	0.249	WESTRIDGE LOT 155	48.5			62.40	\$4,055.81	34.00	\$1,700.00	\$6,481.61	\$759.64
SIPP, SHARIA	1645 WESTRIDGE DR	1645 WESTRIDGE DR	CASPER, WY 82604	0.160	WESTRIDGE LOT 96	61.8			75.70	\$4,920.31			\$5,540.76	\$649.55
SMITH MICHAEL F ET UX	1848 WESTRIDGE CIR	1848 WESTRIDGE CIR	CASPER, WY 82604	0.240	WESTRIDGE LOT 175	45.5			59.40	\$3,860.81	20.00	\$1,000.00	\$5,473.75	\$641.69
SMITH, ROCKY D ET UX	1888 WESTRIDGE CIR	1888 WESTRIDGE CIR	CASPER, WY 82604	0.250	WESTRIDGE LOT 177	62	113.6	18	96.90	\$8,233.31			\$7,019.33	\$822.88
STUDDARD WAGHAN	1544 WESTRIDGE DR	1544 WESTRIDGE DR	CASPER, WY 82604	0.143	WESTRIDGE LOT 110	55			68.90	\$4,478.31			\$5,043.02	\$591.20
TALADA ROD A	1722 WESTRIDGE CIR	1722 WESTRIDGE CP	CASPER, WY 82604	0.168	WESTRIDGE LOT 166	61			74.90	\$4,868.31	16.00	\$800.00	\$6,383.08	\$748.29
THOMAS, JAMES L ET UX	1681 WESTRIDGE CIR	1681 WESTRIDGE CIR	CASPER, WY 82604	0.247	WESTRIDGE LOT 147	41.8	50	120	66.70	\$3,620.31	36.00	\$1,750.00	\$6,047.50	\$706.05
TRAYLOR JAMES E	1555 WESTRIDGE DR	1555 WESTRIDGE DR	CASPER, WY 82604	0.143	WESTRIDGE LOT 91	55			68.90	\$4,478.31			\$5,043.02	\$591.20
TRIPLE M WESTSIDE PROPERTIES LLC	2044 WESTWOOD HILL	PO BOX 1778, CASPER, WY 82602	CASPER, WY 82602	0.298	WESTWOOD #3 LOT 818 COMMERCIAL	80.7			94.60	\$8,148.81			\$8,924.17	\$811.72
WHALEN RICHARD A ET AL	1650 WESTRIDGE DR	1650 WESTRIDGE DR	CASPER, WY 82604	0.195	WESTRIDGE LOT 117	57.1			71.00	\$4,614.81			\$5,196.73	\$609.22
WIEBE ZAKERY D ET UX	1515 WESTRIDGE DR	1515 WESTRIDGE DR	CASPER, WY 82604	0.143	WESTRIDGE LOT 87	55			68.90	\$4,478.31			\$5,043.02	\$591.20
WILSON, SHAWN M ET UX	1673 WESTRIDGE TER	1673 WESTRIDGE TR	CASPER, WY 82604	0.187	WESTRIDGE LOT 126	58			71.90	\$4,673.31			\$5,262.61	\$616.94
WOOD DALE F	1626 WESTRIDGE TER	1626 WESTRIDGE TR	CASPER, WY 82604	0.196	WESTRIDGE LOT 141	102			115.90	\$7,533.31	15.00	\$750.00	\$9,327.83	\$1,093.51
Total Estimated Assessment									\$8,415.00	\$546,975.00	962.00	\$48,100.00	\$670,113.96	

Note: 1) The above opinions of estimated assessment have been increased by 12.61% (1.1261 multiplier) for traffic control, design and construction engineering, contingency and incidental construction costs.

Note: 2) Corner lots have been assessed on the short side with the long side and corner radius distributed throughout Phase One. 1,486.98 feet of curbwalk is distributed among 107 total lots.

LAD Westridge Improvements Map

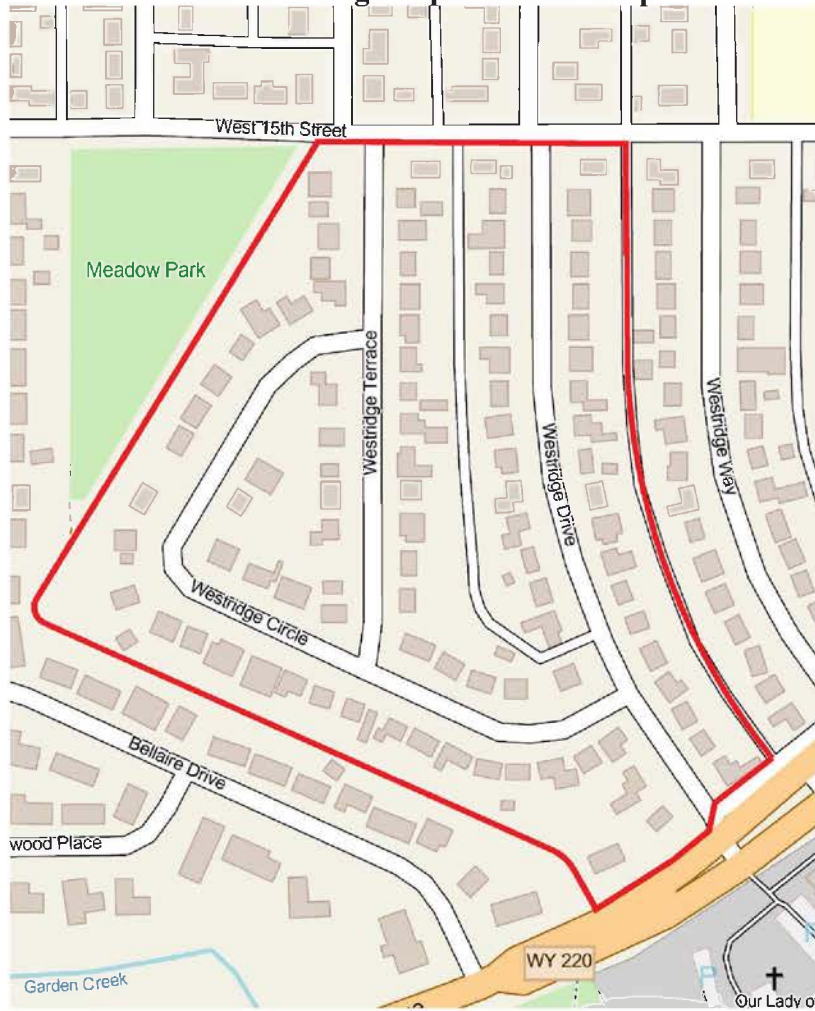

LAD Westridge Improvements
Phase 1

ORDINANCE NO. 7-23 __

AN ORDINANCE APPROVING A ZONE CHANGE OF LOT 1, MAJESTIC MOUNTAIN ADDITION, FROM PH (PARK HISTORIC) TO C-2 (GENERAL BUSINESS)

WHEREAS, Pat Sullivan/Half Barrel Inc. has applied for a zone change of Lot 1, Majestic Mountain Addition, located immediately east of the Paradise Valley public pool and north of the Iris Street cul-de-sac, from PH (Park Historic) to C-2 (General Business): and,

WHEREAS, the City Council originally sold the subject property via Resolution #06-155; and,

WHEREAS, after a public hearing on March 9, 2023, the City of Casper Planning and Zoning Commission passed a motion recommending that City Council approve the zone change request; and,

WHEREAS, the governing body of the City of Casper finds that the above described zone change should be approved.

NOW, THEREFORE, BE IT ORDAINED BY THE GOVERNING BODY OF THE CITY OF CASPER, WYOMING:

SECTION 1:

Lot 1, Majestic Mountain Addition, is hereby rezoned from zoning classification PH (Park Historic) to C-2 (General Business).

SECTION 2:

This ordinance shall be in full force and effect from and after passage on three readings and publication pursuant to law.

PASSED on 1st reading the 18th day of April, 2023.

PASSED on 2nd reading the ___ day of _____, 2023.

PASSED, APPROVED, AND ADOPTED on 3rd and final reading the ___ day of _____ 2023.

APPROVED AS TO FORM:

Walter Tremel

ATTEST:

CITY OF CASPER, WYOMING
A Municipal Corporation

Fleur Tremel
City Clerk

Bruce Knell
Mayor

Lot 1, Majestic Mountain Addition - Zone Change

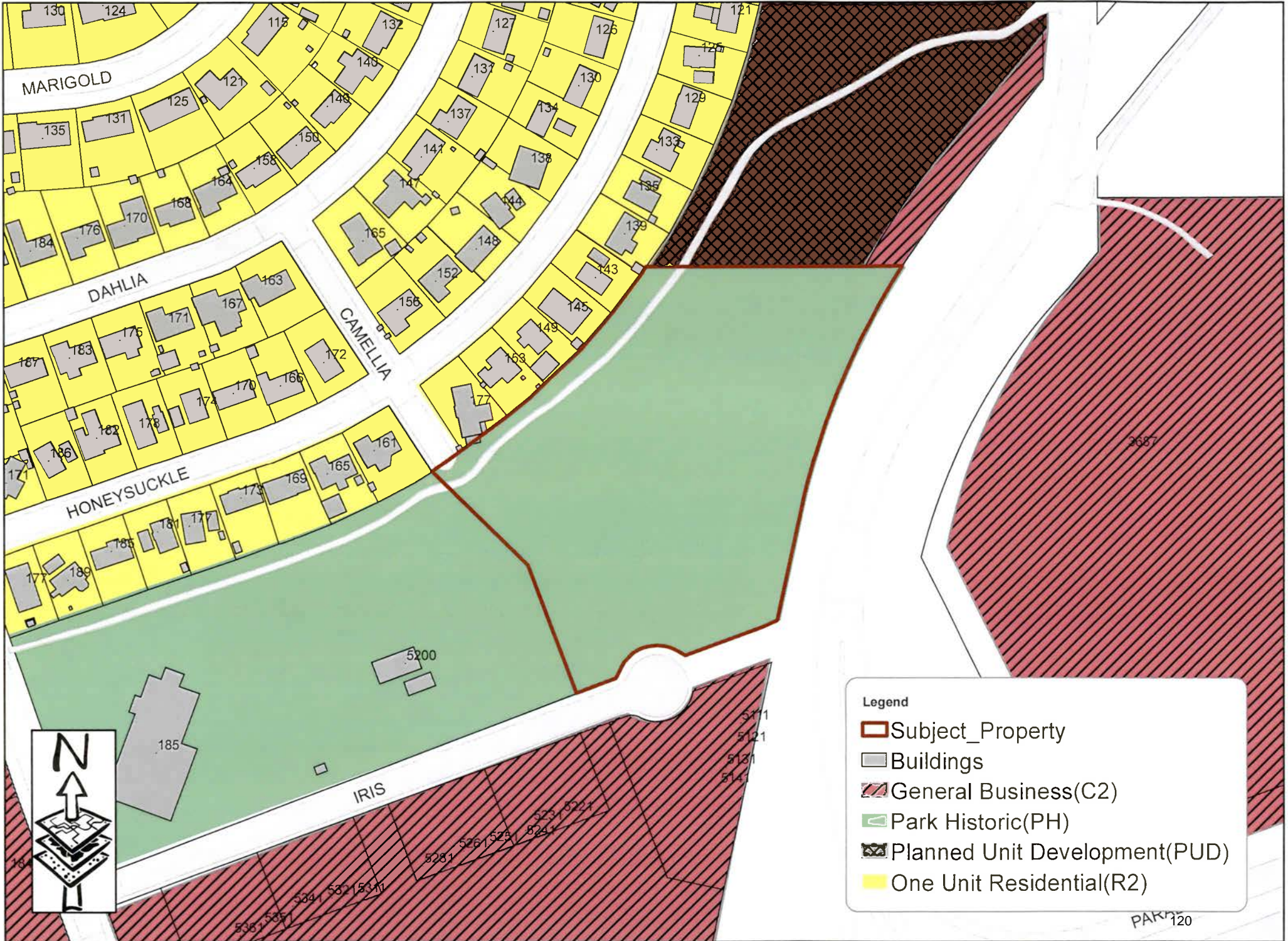

Lot 1, Majestic Mountain Addition - Zone Change



MARIGOLD

DAHLIA

CAMELLIA

HONEYSUCKLE

VALLEY DR

IRIS

PARADISE DR

COLUMBINE

CARNATION

CY AVE

PRIVATE DR



Legend

 Subject_Property

ORDINANCE NO. 8-23

AN ORDINANCE APPROVING THE HIGHLAND PARK
TENNIS COMPLEX ADDITION, AND THE ASSOCIATED
SUBDIVISION AGREEMENT

WHEREAS, an application has been made for final plat approval of the Highland Park Tennis Complex Addition, comprising 4.57-acres, more or less, and located generally south and west of the intersection of South Beverly Street and East 4th Street (the “plat”); and,

WHEREAS, the plat consists of previously unplatted land located within SE1/4NE1/4 of Section 10, T.33N., R79W., 6th P.M. Natrona County, Wyoming, as well as a portion of the City of Casper Highland Park Addition; and,

WHEREAS, a written subdivision agreement will be entered into with the City of Casper, which will be approved with the plat upon third reading of this ordinance; and,

WHEREAS, the plat requires approval by ordinance following a public hearing; and,

WHEREAS, after a public hearing, the City of Casper Planning and Zoning Commission passed a motion recommending that the City Council approve the request to plat the above referenced property; and,

WHEREAS, the governing body of the City of Casper finds that the above described plat and subdivision agreements should be approved.

NOW, THEREFORE, BE IT ORDAINED BY THE GOVERNING BODY OF THE CITY OF CASPER, WYOMING:

SECTION 1:

That the Mayor is hereby authorized and directed to execute, and the City Clerk to attest, the Highland Park Tennis Complex Addition Subdivision Agreement.

SECTION 2:

That the final plat of the Highland Park Tennis Complex Addition is hereby approved under terms and conditions of the Highland Park Tennis Complex Addition Subdivision Agreement.

SECTION 3:

This ordinance shall be in full force and effect from and after passage on three readings and publication pursuant to law.

PASSED on 1st reading the 18th day of April, 2023.

PASSED on 2nd reading the ____ day of _____, 20__.

PASSED, APPROVED, AND ADOPTED on 3rd and final reading the ____ day of _____, 20__.

APPROVED AS TO FORM:

Waller Tremel

ATTEST:

CITY OF CASPER, WYOMING
A Municipal Corporation

Fleur Tremel
City Clerk

Bruce Knell
Mayor

M:\Land_2021\Surveying\21-246 Highland Park Plat\Survey Plat\Highland Park Tennis Complex Addition.dwg, 1/12/2023, Bill

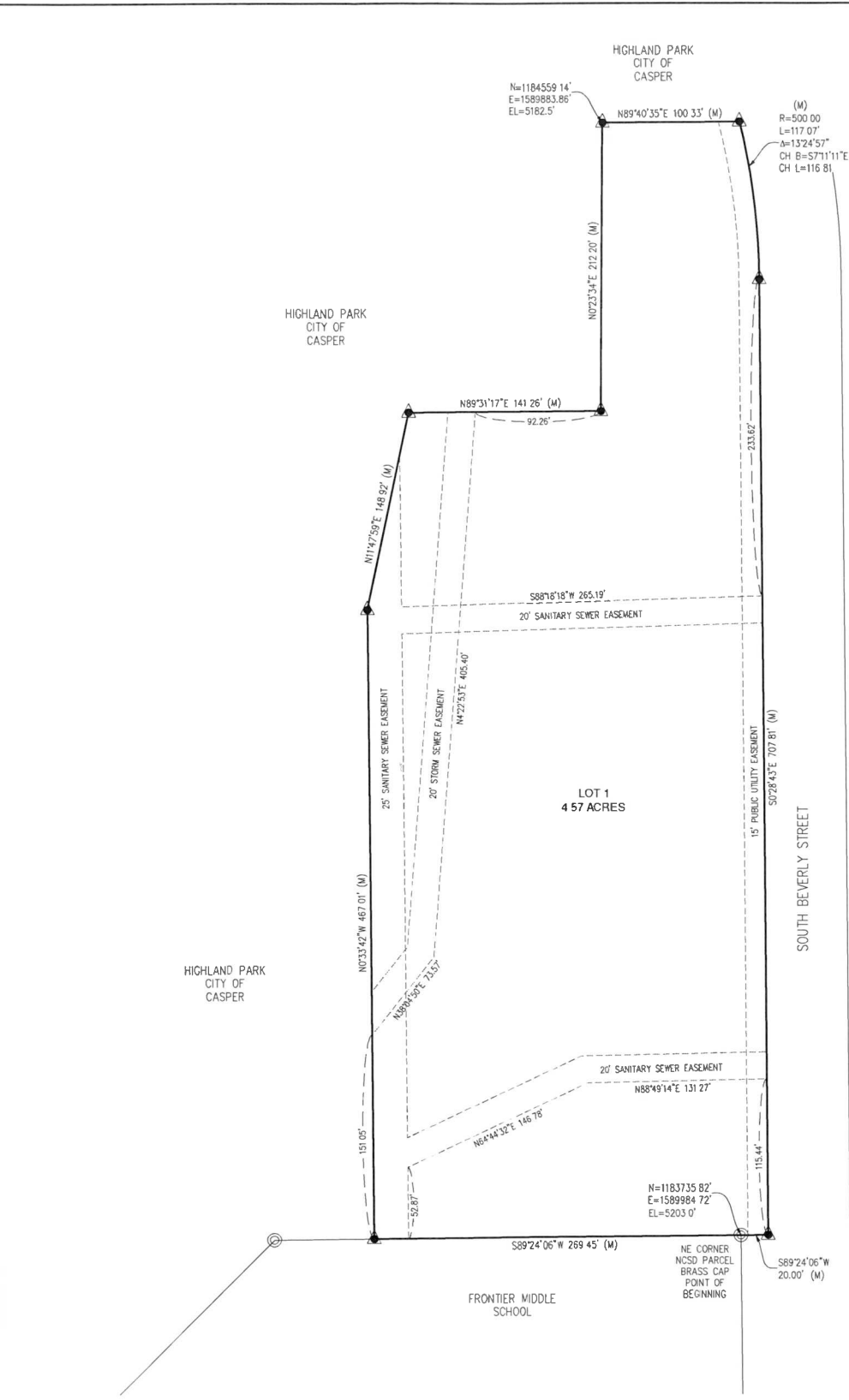

- LEGEND**
- ▲ SET BRASS CAP
 - SET MONUMENT 5/8" REBAR & ALUMINUM CAP
 - ⊙ FOUND MONUMENT AS NOTED

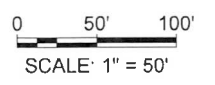

VICINITY MAP
NO SCALE

APPROVALS

APPROVED BY THE CITY OF CASPER PLANNING AND ZONING COMMISSION OF CASPER, WYOMING
THIS _____ DAY OF _____ 2023

ATTEST _____ SECRETARY _____ CHAIRMAN

APPROVED BY THE CITY COUNCIL OF CASPER, WYOMING BY RESOLUTION NO _____ DULY PASSED,
ADOPTED AND APPROVED THIS _____ DAY OF _____ 2023.

ATTEST _____ CITY CLERK _____ MAYOR

INSPECTED AND APPROVED THIS _____ DAY OF _____ 2023 _____ CITY ENGINEER

INSPECTED AND APPROVED THIS _____ DAY OF _____ 2023 _____ CITY SURVEYOR

NOTES

- 1 ERROR OF CLOSURE EXCEEDS 1 91,000
- 2 BASIS OF BEARING IS THE WYOMING STATE PLANE COORDINATE SYSTEM, EAST CENTRAL ZONE, NAD 1983/2011
- 3 THE CONVERGENCE ANGLE AT THE POINT OF BEGINNING IS 00°42'14.57", AND THE COMBINED FACTOR IS 0.99977693
- 4 ALL DISTANCES ARE GRID
- 5 ELEVATIONS SHOWN HEREON ARE BASED ON NAVD 88 DATUM AND ARE NOT MEANT TO USED AS BENCHMARKS.

CERTIFICATE OF SURVEYOR

STATE OF WYOMING }
COUNTY OF NATRONA } SS

I, WILLIAM R. FEHRINGER, A REGISTERED PROFESSIONAL LAND SURVEYOR, LICENSE NO. 5528, DO HEREBY CERTIFY THAT THIS PLAT WAS MADE FROM NOTES TAKEN DURING AN ACTUAL SURVEY MADE UNDER MY DIRECT SUPERVISION IN NOVEMBER, 2021, AND THAT THIS PLAT, TO THE BEST OF MY KNOWLEDGE AND BELIEF, CORRECTLY AND ACCURATELY REPRESENTS SAID SURVEY. ALL DIMENSIONS ARE EXPRESSED IN FEET AND DECIMALS THEREOF AND COURSES REFERRED TO THE TRUE MERIDIAN. ALL BEING TRUE AND CORRECT TO THE BEST OF MY KNOWLEDGE AND BELIEF.

THE FOREGOING INSTRUMENT WAS ACKNOWLEDGED BEFORE ME BY WILLIAM R. FEHRINGER
THIS DAY OF _____, 2023
WITNESS MY HAND AND OFFICIAL SEAL.
MY COMMISSION EXPIRES _____

NOTARY PUBLIC

CERTIFICATE OF DEDICATION

STATE OF WYOMING }
COUNTY OF NATRONA } SS

THE UNDERSIGNED, NATRONA COUNTY SCHOOL DISTRICT, DO HEREBY CERTIFY THAT THEY ARE THE OWNERS AND PROPRIETORS OF THE FOLLOWING DESCRIBED UNPLATTED PARCEL OF LAND SITUATE IN THE SE[] OF SECTION 10, T.33N., R.79W., 6TH P.M. NATRONA COUNTY, WYOMING, BEING MORE PARTICULARLY DESCRIBED AS FOLLOWS:

COMMENCING AT THE NORTHEAST CORNER OF THE FRONTIER MIDDLE SCHOOL PARCEL, MONUMENTED BY A BRASS CAP AND BEING THE POINT OF BEGINNING,

THENCE S89°24'06"W, ALONG THE SOUTH LINE OF THE CITY OF CASPER HIGHLAND PARK AND THE NORTH LINE OF THE FRONTIER MIDDLE SCHOOL PARCEL, A DISTANCE OF 269.45 FEET TO THE SOUTHWEST CORNER OF THE PARCEL, MONUMENTED BY A BRASS CAP,

THENCE N00°33'42"W ALONG THE WEST LINE OF THE PARCEL, A DISTANCE OF 467.01 FEET TO A POINT, MONUMENTED BY A BRASS CAP,

THENCE N11°47'59"E, ALONG THE WEST LINE OF THE PARCEL, A DISTANCE OF 148.92 FEET TO THE NORTHWEST CORNER OF THE PARCEL, MONUMENTED BY A BRASS CAP,

THENCE N89°31'17"E, ALONG THE NORTH LINE OF THE PARCEL, A DISTANCE OF 141.26 FEET TO A POINT MONUMENTED BY A BRASS CAP,

THENCE N00°23'34"E, ALONG THE WEST LINE OF THE PARCEL, A DISTANCE OF 212.20 FEET TO THE NORTHWEST CORNER OF THE PARCEL, MONUMENTED BY A BRASS CAP,

THENCE N89°40'35"E, ALONG THE NORTH LINE OF THE PARCEL, A DISTANCE OF 100.33 FEET TO THE NORTHEAST CORNER OF THE PARCEL, LOCATED ON THE WEST LINE OF SOUTH BEVERLY STREET, MONUMENTED BY A BRASS CAP,

THENCE IN A SOUTHEAST DIRECTION ALONG THE WEST LINE OF SOUTH BEVERLY STREET AND A CURVE TO THE RIGHT HAVING A RADIUS OF 500.00 FEET, THROUGH A CENTRAL ANGLE OF 132°4'57", A DISTANCE OF 117.07 FEET, WITH A CHORD BEARING OF S07°11'11"E, A DISTANCE OF 116.81 FEET TO THE END OF CURVE, MONUMENTED BY A BRASS CAP,

THENCE S00°28'43"E, ALONG THE EAST LINE OF THE PARCEL AND THE WEST LINE OF SOUTH BEVERLY STREET, A DISTANCE OF 707.81 FEET TO THE SOUTHEAST CORNER OF THE PARCEL, MONUMENTED BY A BRASS CAP,

THENCE S89°24'06"W, ALONG THE SOUTH LINE OF THE PARCEL, A DISTANCE OF 20.00 FEET TO THE POINT OF BEGINNING

THE ABOVE DESCRIBED TRACT OF LAND CONTAINS 4.57 ACRES, AND IS SUBJECT TO ANY RIGHTS-OF-WAY AND/OR EASEMENTS, RESERVATIONS AND ENCUMBRANCES WHICH HAVE BEEN LEGALLY ACQUIRED

THE PARCEL OF LAND, AS IT APPEARS ON THIS PLAT, IS DEDICATED WITH THE FREE CONSENT AND IN ACCORDANCE WITH THE DESIRES OF THE UNDERSIGNED OWNERS AND PROPRIETORS. THE NAME OF THE SUBDIVISION SHALL BE "HIGHLAND PARK TENNIS COMPLEX ADDITION" AND THE OWNERS HEREBY GRANT TO THE PUBLIC AND PRIVATE UTILITY COMPANIES AN EASEMENT AND LICENSE TO LOCATE, CONSTRUCT, USE AND MAINTAIN CONDUITS, LINES, WIRES AND PIPES, ANY OR ALL OF THEM, UNDER AND ALONG THE STRIPS OF LAND MARKED "15' PUBLIC UTILITY EASEMENT", "20' STORM SEWER EASEMENT", "20' SANITARY SEWER EASEMENT" AND "25' SANITARY SEWER EASEMENT" AS SHOWN ON THIS PLAT. ALL ROADS AND STREETS AS SHOWN HEREON ARE HEREBY, OR HAVE BEEN PREVIOUSLY, DEDICATED TO THE USE OF THE PUBLIC

NATRONA COUNTY SCHOOL DISTRICT
970 NORTH GLENN ROAD
CASPER, WY 82601

RAYMOND CATELLIER -
NCSD SCHOOL BOARD CHAIRMAN

THE FOREGOING INSTRUMENT WAS ACKNOWLEDGED BEFORE ME BY RAYMOND CATELLIER,
NCSD SCHOOL BOARD CHAIRMAN, THIS _____ DAY OF _____ 2023

WITNESS MY HAND AND OFFICIAL SEAL.
MY COMMISSION EXPIRES _____

NOTARY PUBLIC

PLAT OF A PORTION OF
THE CITY OF CASPER
HIGHLAND PARK
AS
**HIGHLAND PARK TENNIS
COMPLEX ADDITION**
AN ADDITION TO THE CITY OF CASPER, WYOMING
BEING A PORTION OF THE SE[]
SECTION 10, T.33N., R.79W., 6TH P.M.
NATRONA COUNTY WYOMING
JANUARY, 2023
WO #21-246

Proposed - Highland Park Tennis Complex Addition



Proposed - Highland Park Tennis Complex Addition

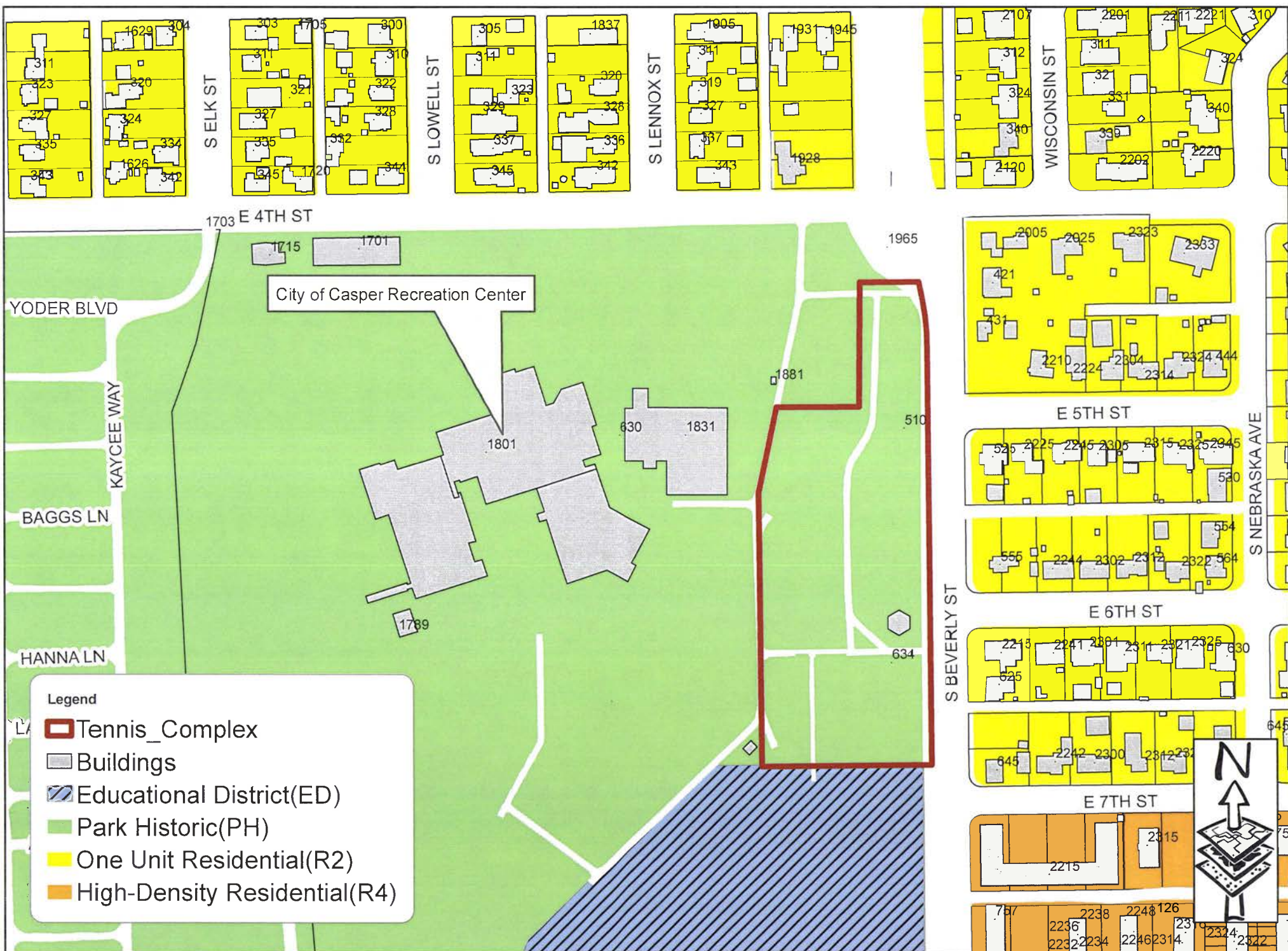

Legend

- Tennis_Complex
- Buildings
- Educational District(ED)
- Park Historic(PH)
- One Unit Residential(R2)
- High-Density Residential(R4)



ORDINANCE NO. 9-23

AN ORDINANCE APPROVING A PLAT, SUBDIVISION AGREEMENT AND ZONE CHANGE FOR THE LUKASIEWICZ SUBDIVISION IN THE CITY OF CASPER, WYOMING.

WHEREAS Del Lukasiewicz has applied for plat approval to create the Lukasiewicz Subdivision, comprising 4.6-acres, more or less located in the NW1/4NW1/4 of Section 23, T.33N., R80W., 6th PM, Natrona County, Wyoming, as well as portions of Lots 22 and 23 in the Paradise Valley Addition; and,

WHEREAS application has also been made to zone the proposed Lukasiewicz Subdivision as AG (Urban Agriculture); and,

WHEREAS, a written subdivision agreement will be entered into with the City of Casper, which will be executed with the approval of the plat upon third reading of this ordinance; and,

WHEREAS, after a public hearing, the City of Casper Planning and Zoning Commission passed a motion recommending that City Council approve the plat and zoning requests; and,

WHEREAS, this platting and zoning requires approval of the City Council, by ordinance, following a public hearing; and,

WHEREAS, the governing body of the City of Casper finds that the above-described plat, zoning request, and the associated subdivision agreement should be approved.

NOW, THEREFORE, BE IT ORDAINED BY THE GOVERNING BODY OF THE CITY OF CASPER, WYOMING:

SECTION 1:

The plat of the Lukasiewicz Subdivision and the associated subdivision agreement, as described above, are hereby approved, and the Mayor is hereby authorized and directed to execute, and the City Clerk to attest said documents.

SECTION 2:

That the above-described zoning of the Lukasiewicz Addition as AG (Urban Agriculture) is hereby approved.

SECTION 3:

This ordinance shall be in full force and effect from and after passage on three readings and publication pursuant to law.

PASSED on 1st reading the 18th day of April, 20 23.

PASSED on 2nd reading the ____ day of _____, 20 ____.

PASSED, APPROVED, AND ADOPTED on 3rd and final reading the ____ day of _____, 20 ____.

APPROVED AS TO FORM:



ATTEST:

Fleur Tremel
City Clerk

CITY OF CASPER, WYOMING
A Municipal Corporation

Bruce Knell
Mayor

PLAT OF LUKASIEWICZ SUBDIVISION

LOCATED IN THE NW1/4NW1/4 SECTION 23, T.33N.,
R.80W., 6TH P.M.,
NATRONA COUNTY, WYOMING

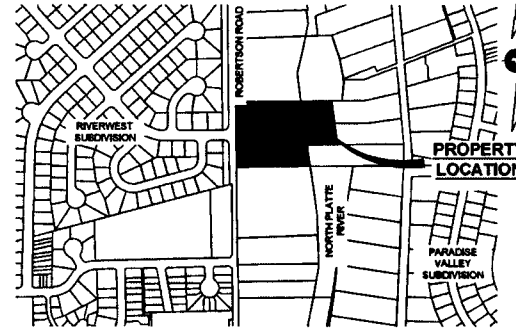

VICINITY MAP
NATRONA COUNTY, WY
SCALE: 1" = 500'

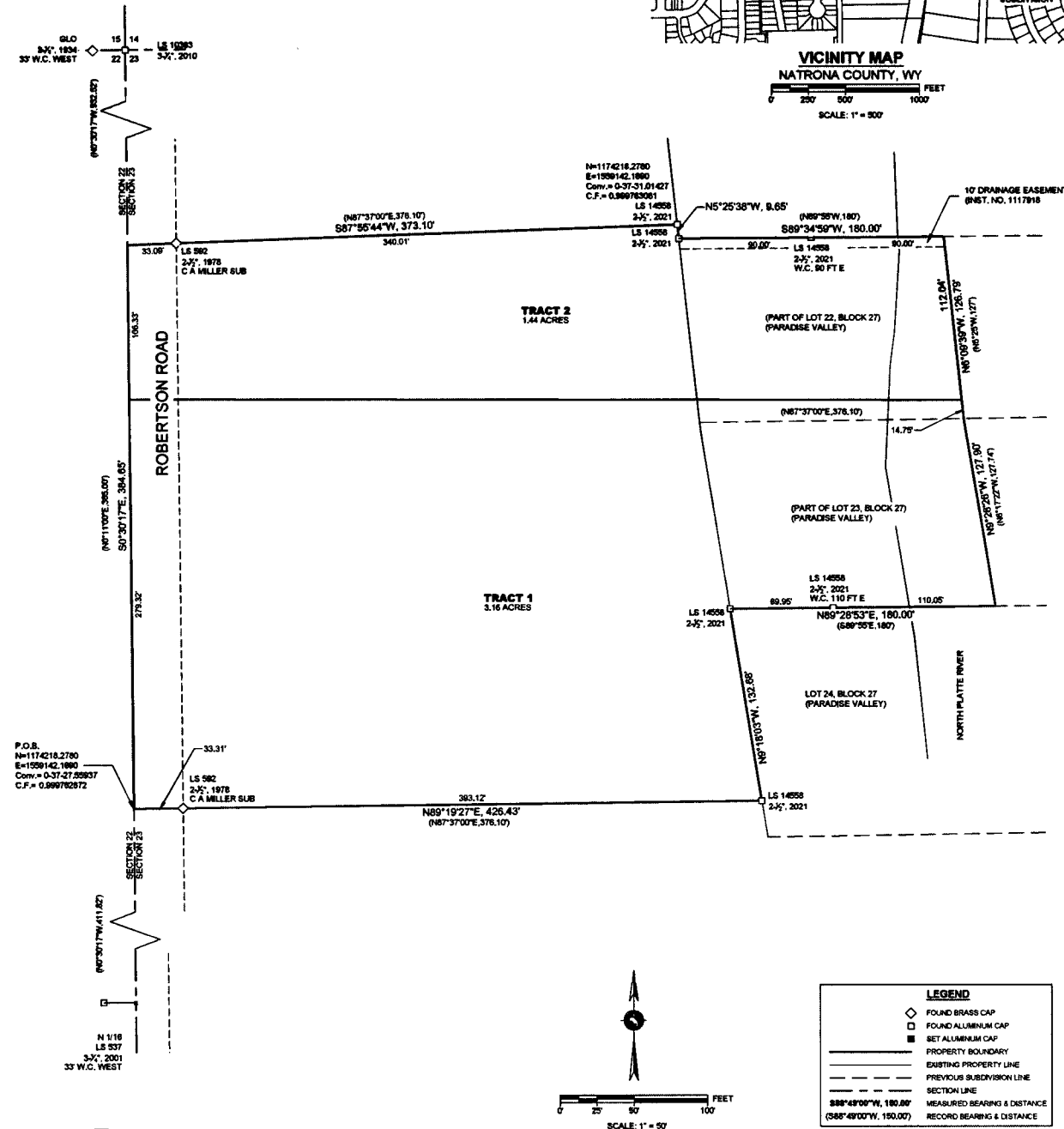

CERTIFICATE OF DEDICATION:

THE UNDERSIGNED, DEL LUKASIEWICZ, DOES HEREBY CERTIFY THAT HE IS THE OWNER AND PROPRIETOR OF THE FOLLOWING DESCRIBED PARCEL OF LAND, SITUATED IN THE NW1/4NW1/4 SECTION 23, T.33N., R.80W., 6TH P.M., NATRONA COUNTY, WYOMING, AND INCLUDES PORTIONS OF LOTS 22 AND 23 OF BLOCK 27 OF THE PARADISE VALLEY SUBDIVISION, BEING MORE PARTICULARLY DESCRIBED BY METES AND BOUNDS AS FOLLOWS:

COMMENCING AT THE N1/8 CORNER COMMON TO SAID SECTION 23 AND SECTION 22, T.33N., R.80W., SAID CORNER BEING REFERENCED BY AN ALUMINUM CAP WITNESS CORNER THAT BEARS S.89°19'27"W., 33.31 FEET FROM SAID N1/8 CORNER; THENCE N00°30'17"W., ALONG THE WEST LINE OF SAID SECTION 23, 411.82 FEET TO THE POINT OF BEGINNING OF THIS LEGAL DESCRIPTION, SAID POINT BEING THE SOUTHWEST CORNER OF THE PARCEL OF LAND BEING DESCRIBED HEREIN; THENCE N89°19'27"E., ALONG THE SOUTHERLY LINE OF THE PARCEL OF LAND BEING DESCRIBED HEREIN, 33.31 FEET TO A FOUND BRASS CAP ON THE EASTERLY RIGHT-OF-WAY LINE OF ROBERTSON ROAD; THENCE N89°19'27"E., CONTINUING ALONG THE SOUTHERLY LINE OF THE PARCEL OF LAND BEING DESCRIBED HEREIN, 393.12 FEET TO A FOUND ALUMINUM CAP AT AN ANGLE POINT IN THIS LEGAL DESCRIPTION, SAID POINT BEING LOCATED ON THE WESTERLY LINE OF LOT 24, BLOCK 27 OF THE PARADISE VALLEY SUBDIVISION; THENCE N09°18'03"W., ALONG THE WESTERLY LINE OF SAID LOT 24 AND THE EASTERLY LINE OF THE PARCEL OF LAND BEING DESCRIBED HEREIN, 132.88 FEET TO A FOUND ALUMINUM CAP AT THE SOUTHWEST CORNER OF LOT 23, BLOCK 27 OF THE PARADISE VALLEY SUBDIVISION; THENCE N89°28'53"E., ALONG THE SOUTHERLY LINE OF SAID LOT 23 AND THE SOUTHERLY LINE OF THE PARCEL OF LAND BEING DESCRIBED HEREIN, 180.00 FEET TO THE SOUTHEAST CORNER OF THIS PARCEL OF LAND; THENCE N09°28'28"W., ALONG THE EASTERLY LINE OF THE PARCEL OF LAND BEING DESCRIBED HEREIN, 127.90 FEET TO AN ANGLE POINT BEING LOCATED ON THE LOT LINE COMMON TO SAID LOTS 22 AND 23, BLOCK 27 OF THE PARADISE VALLEY SUBDIVISION; THENCE N06°09'30"W., CONTINUING ALONG THE EASTERLY LINE OF THE PARCEL OF LAND BEING DESCRIBED HEREIN, 126.79 FEET TO NORTHEAST CORNER OF THE PARCEL OF LAND BEING DESCRIBED HEREIN, SAID POINT BEING LOCATED ON THE NORTH LINE OF SAID LOT 22, BLOCK 27 OF THE PARADISE VALLEY SUBDIVISION; THENCE S89°34'59"W., ALONG THE NORTHERLY LINE OF SAID LOT 22 AND THE NORTHERLY LINE OF THE PARCEL OF LAND BEING DESCRIBED HEREIN, 180.00 FEET TO A FOUND ALUMINUM CAP AT AN ANGLE POINT IN THIS LEGAL DESCRIPTION; THENCE N05°25'38"W., CONTINUING ALONG THE NORTHERLY LINE OF THE PARCEL OF LAND BEING DESCRIBED HEREIN, 9.65 FEET TO A FOUND ALUMINUM CAP AT AN ANGLE POINT IN THIS LEGAL DESCRIPTION; THENCE S87°55'44"W., CONTINUING ALONG THE NORTHERLY LINE OF THE PARCEL OF LAND BEING DESCRIBED HEREIN, 340.01 FEET TO A FOUND BRASS CAP ON THE EASTERLY RIGHT-OF-WAY LINE OF ROBERTSON ROAD; THENCE S87°55'44"W., CONTINUING ALONG THE NORTHERLY LINE OF THE PARCEL OF LAND BEING DESCRIBED HEREIN, 33.09 FEET TO THE NORTHWEST CORNER OF THE PARCEL OF LAND BEING DESCRIBED HEREIN; THENCE S00°30'17"E., ALONG THE WESTERLY LINE OF THE PARCEL OF LAND BEING DESCRIBED HEREIN, 364.95 FEET TO THE POINT OF BEGINNING.

THE ABOVE DESCRIBED PARCEL OF LAND CONTAINS 4.60 ACRES, AND IS SUBJECT TO ALL RIGHTS-OF-WAY AND/OR EASEMENTS, RESERVATIONS AND ENCROACHMENTS WHICH HAVE BEEN LEGALLY ACQUIRED.

THE TRACT OF LAND, AS IT APPEARS ON THIS PLAT, IS DEDICATED WITH THE FREE CONSENT AND IN ACCORDANCE WITH THE DESIRES OF THE ABOVE NAMED OWNERS AND PROPRIETORS. THE NAME OF THE SUBDIVISION SHALL BE KNOWN AS LUKASIEWICZ SUBDIVISION. ALL STREETS AS SHOWN HEREON ARE HEREBY OR WERE PREVIOUSLY DEDICATED TO THE USE OF THE PUBLIC AND EASEMENTS SHOWN HEREON ARE HEREBY DEDICATED FOR THE USE OF PUBLIC AND PRIVATE UTILITY COMPANIES FOR THE PURPOSES OF CONSTRUCTION, OPERATION, AND MAINTENANCE OF UTILITY LINES, CONDUITS, DITCHES, DRAINAGE, AND ACCESS.

DEL LUKASIEWICZ
3541 MAPLEWOOD LN
JOHNSTOWN, CO 80534-4101

CITY OF CASPER
200 N. DAVID STREET
CASPER, WY 82601

DEL LUKASIEWICZ

THE FORGOING INSTRUMENT WAS ACKNOWLEDGED BEFORE ME BY DEL LUKASIEWICZ, THIS _____ DAY OF _____, 2023.

WITNESS MY HAND AND OFFICIAL SEAL

MY COMMISSION EXPIRES: _____

NOTARY PUBLIC

APPROVALS

APPROVED: PLANNING AND ZONING COMMISSION CASPER, WYOMING

THIS _____ DAY OF _____, 2023 AND FORWARDED TO THE CITY COUNCIL OF CASPER, WYOMING WITH

RECOMMENDATION THAT SAID PLAT BE APPROVED.

COMMISSION CHAIRMAN _____

SECRETARY _____

APPROVED: CITY COUNCIL OF THE CITY OF CASPER, WYOMING BY ORDINANCE NUMBER _____ DULY PASSED, ADOPTED AND

APPROVED ON THIS _____ DAY OF _____, 2023.

MAYOR _____

ATTEST: CITY CLERK _____

BRUCE KHELL - MAYOR

STATE OF WYOMING)
) SS
COUNTY OF NATRONA)

THE FOREGOING INSTRUMENT WAS ACKNOWLEDGED BEFORE ME THIS _____ DAY OF _____, 2023, BY BRUCE KHELL - MAYOR,
CITY OF CASPER

WITNESS MY HAND AND OFFICIAL SEAL.

NOTARY PUBLIC _____

MY COMMISSION EXPIRES _____

INSPECTED AND APPROVED ON THIS _____ DAY OF _____, 2023.

CITY ENGINEER _____

INSPECTED AND APPROVED ON THIS _____ DAY OF _____, 2023.

CITY SURVEYOR _____

CERTIFICATE OF SURVEYOR

I, JAMES F. JONES, DO HEREBY CERTIFY THAT I AM A PROFESSIONAL LAND SURVEYOR, REGISTERED UNDER THE LAWS OF THE STATE OF WYOMING, THAT THIS PLAT IS A TRUE, CORRECT AND COMPLETE PLAT OF LUKASIEWICZ SUBDIVISION TO THE CITY OF CASPER, WYOMING, AS LAID OUT, PLATTED, DEDICATED AND SHOWN HEREON, AND THAT THIS PLAT WAS MADE FROM NOTES TAKEN DURING AN ACTUAL SURVEY MADE BY ME OR UNDER MY DIRECT SUPERVISION IN AUGUST, 2022, AND THAT THIS PLAT TO THE BEST OF MY KNOWLEDGE AND BELIEF CORRECTLY AND ACCURATELY REPRESENTS SAID SURVEY.

STATE OF WYOMING)
) SS
COUNTY OF NATRONA)

THIS THE FOREGOING INSTRUMENT WAS ACKNOWLEDGED BEFORE ME BY JAMES F. JONES

THIS _____ DAY OF _____, 2023.

WITNESS MY HAND AND OFFICIAL SEAL.

NOTARY PUBLIC _____

MY COMMISSION EXPIRES _____



Environmental and Civil Solutions, LLC
111 West 2nd Street, Suite 600
Casper, WY 82604
Phone: 307.337.2883
www.ecsengineers.net

PROJECT NO. 220039 11x17

OWNER:
DEL LUKASIEWICZ
3541 MAPLEWOOD LN
JOHNSTOWN, CO 80534-4101

SURVEYOR:
FIELD: BP & TY
REVIEW: JAMES F. JONES, P.L.S.

DATE DRAWN:
1.03.2023

NOTES

1. ERROR OF CLOSURE EXCEEDS 1:157,000
2. BEARINGS AND COORDINATES ARE BASED ON WYOMING STATE PLANE COORDINATE SYSTEM, EAST CENTRAL ZONE, NAD 1983/2011.
3. ELEVATIONS ARE NAVD83 AND NOT TO BE USED AS BENCHMARKS.
4. DISTANCES: US SURVEY FOOT/GRID.

Proposed Lukasiewicz Subdivision

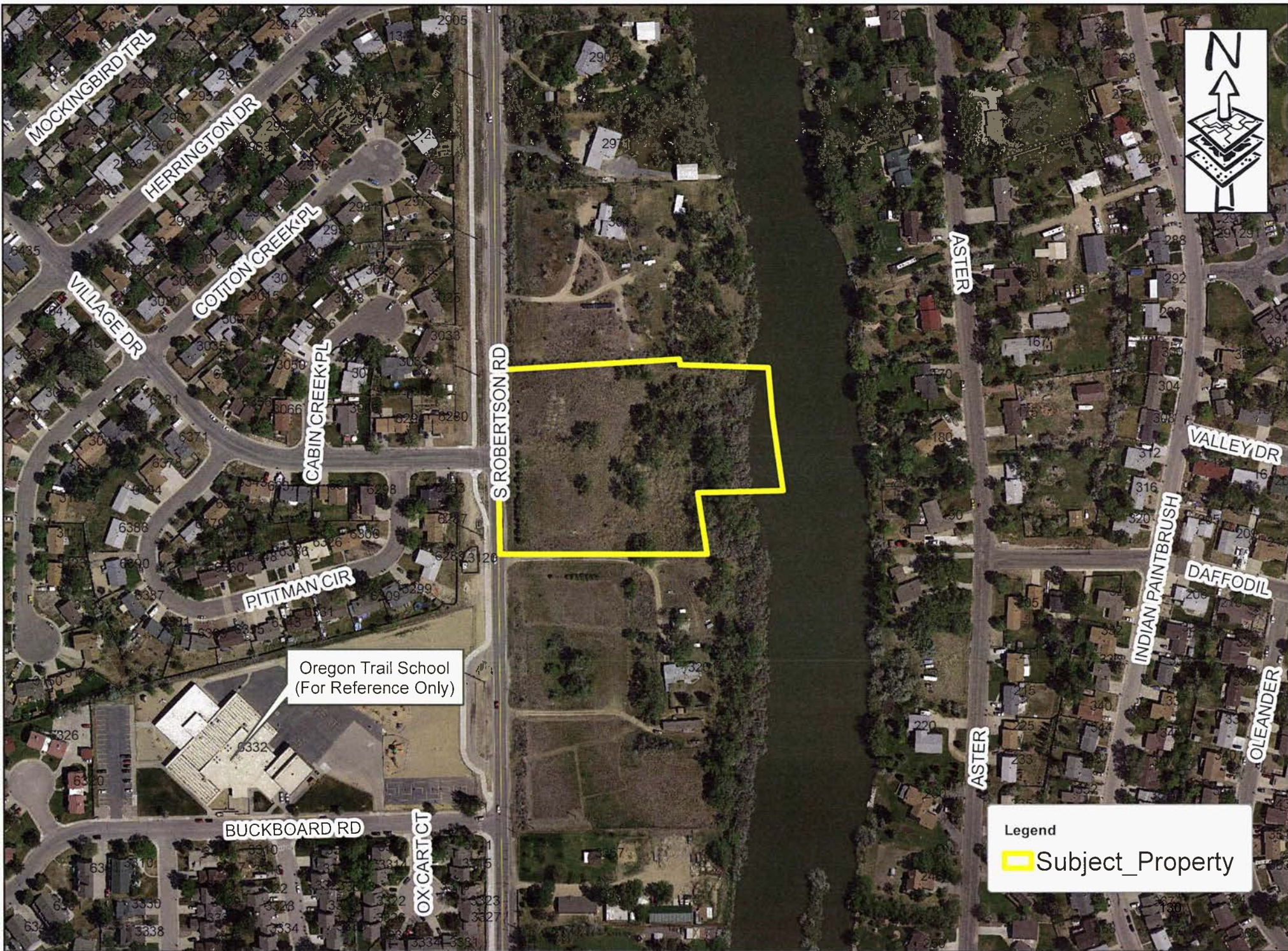

Proposed Lukasiewicz Subdivision



ORDINANCE NO. 5-23

AN ORDINANCE UPDATING AND AMENDING
CHAPTER 5.08 OF THE CASPER MUNICIPAL CODE,
INCLUDING: SECTIONS 5.08.150 and 5.08.390.

WHEREAS, authority is granted to cities and towns by W.S. §15-1-103(a) (iv), (xiii) and (xli) to adopt ordinances and regulations for the health, welfare, and safety of the city and to license and regulate business activities within the City for the health, safety, and welfare of its citizens; and,

WHEREAS, the governing body of cities and towns may perform all acts in relation to the property and concerns of the city or town necessary to the exercise of its corporate powers; and,

WHEREAS, incorporated cities, towns and counties within Wyoming are the entities which are charged with licensing, regulating and prohibiting the retail sale of alcoholic and malt beverages within their jurisdictions (Wyo. Stat. 12-4-101(a)); and,

WHEREAS, the Casper Municipal Code regarding alcohol beverages requires updating from time to time; and,

WHEREAS, In July of 2021 the State Statute was repealed preventing one person from owning two liquor licenses; and

WHEREAS, In July of 2017 the State statute was repealed for the hours of operation and allowed each municipality to determine hours of operation.

NOW, THEREFORE, BE IT ORDAINED BY THE GOVERNING BODY OF THE CITY OF CASPER, WYOMING: That the following sections of Chapter 5.08 of the Casper Municipal Code are hereby updated and amended as follows:

5.08.150 License holder restrictions.

- A. A license or permit authorized by this chapter shall not be held by, issued or transferred to:
1. Any party who does not own the licensed building or hold a written lease for a period for which the license will be effective, containing an agreement by the lessor that alcoholic liquor or malt beverages may be sold upon the leased premises, except as provided by subdivision 2 of this subsection;
 2. Any licensee who fails to demonstrate that his licensed alcoholic or malt beverage enterprise will be operational in a planned but not physically functional building within one year after a license or permit has been issued or transferred, or if holding a license, fails to open his business in a functional building within one year after

license issuance or transfer. Upon a showing of good cause by the licensee and for an additional period of not to exceed one year, the local licensing authority may extend the time period in which the business or enterprise of the licensee is required to become operational for business pursuant to this subsection. Any license or permit in violation of this subsection shall not be renewed by the city council;

3. A manufacturer of alcoholic beverages or wholesaler of malt beverages; provided, however, this prohibition is not intended to prevent the manufacture from the sale of alcoholic beverages manufactured by the Casper licensed manufacturer or the sale of malt beverages under a microbrewery license issued pursuant to this Chapter or an off-premises permit pursuant to Section 5.08.105(B)(1) and (B)(2) and except as provided in Section 5.08.100(I).
4. A person under twenty-one years of age;
5. A college fraternity or organization created by one or more college fraternities;
6. A chamber of commerce;
7. A corporation or a limited liability company which has not qualified to do business in Wyoming;
8. An individual who is not a resident; or
9. Any partnership or group of two or more persons unless each individual interested, directly or indirectly, is a resident.
10. Except as provided in subsection 11 of this section, a license or permit authorized by this chapter shall not be renewed if the licensee or permittee did not, during the previous one-year term of the license or permit, purchase at least two hundred fifty dollars (\$250.00) of alcoholic or malt beverages from the commission or any authorized malt beverage wholesaler. A retail liquor license shall not be renewed if the licensee did not, during the previous one-year term of the license, purchase at least two thousand dollars (\$2,000.00) of alcoholic beverages from the division, excluding malt beverage purchases;
11. Subsection 10 of this section shall not apply to:
 - a. Any licensee or permittee having a planned but not physically functional building pursuant to subsection 3 of this section;
 - b. Holders of special permits issued under Sections 5.08.130 and 5.08.140 of this code.

5.08.390 Hours of sale generally—Exceptions—Designation of dates for unrestricted operation.

- A. All licensees shall be controlled by the following schedule for operating hours:
1. A licensee may commence the selling, serving, or dispensing of alcoholic liquors or malt beverages at six a.m. and shall cease the sale of both alcoholic liquor and malt beverages promptly at the hour of two a.m. the following day. Any portion of any building used by the licensee for the selling, serving, dispensing, or consumption of

alcoholic liquors or malt beverages shall be cleared of all persons other than employees by two-thirty a.m. The licensee shall ensure that all consumption of alcoholic liquors or malt beverages has ceased by two-thirty a.m. within all areas of the licensed building, or in the case of resort licensees, within the boundary of the lot or lots under the ownership or lease by the licensee, other than in private hotel or motel rooms;

2. The hours of operating designated in subsection A of this section may be modified on no more than four days each calendar year by a resolution of the city council, designating those dates during city or county fairs, rodeos, pageants, jubilees, special holidays or similar public gatherings when all licensees may continuously operate their licensed building, or licensed resort or club premises for a period of twenty-four hours beginning at six a.m.

PASSED on 1st reading the 4th day of April, 2023

PASSED on 2nd reading the 18th day of April, 2023

PASSED, APPROVED, AND ADOPTED on third and final reading the _____ day of _____, 2023.

APPROVED AS TO FORM:



ATTEST:

Fleur Tremel
City Clerk

CITY OF CASPER, WYOMING
A Municipal Corporation

Bruce Knell
Mayor

April 12, 2023

MEMO TO: J. Carter Napier, City Manager *JCN*

FROM: Liz Becher, Community Development Director *LB*
Beth Andress, MPO Supervisor *BA*
Renee Hardy, MPO Technician *RH*

SUBJECT: Casper Area Metropolitan Planning Organization Electric Fleet Contract Extension

Meeting Type & Date:

Regular Council Meeting, May 2, 2023.

Action Type:

Resolution

Recommendation:

That Council, by resolution, approve Amendment No. 1 to the City of Casper's Contract for Professional Services with HDR Engineering, Inc., for the Casper Area Metropolitan Planning Organization's (MPO) Electric Fleet Conversion Study.

Summary:

On December 6, 2022, the City of Casper and HDR Engineering, Inc., entered into a Contract for Professional Services for the development of the Casper Area Transit Electric Fleet Conversion Study with a completion deadline of May 30, 2023. The MPO and the consultant have agreed on the need to extend the contract to June 30, 2023. The contract extension will allow for a more thorough public review period within the project timeline, and will allow the project team to meet with Casper City Council within that same public review period.

Financial Considerations:

Funding for this project comes from the Casper Area MPO, including federal monies and contributions from member agencies. The City of Casper is the fiscal agent for the federal funds of the MPO. As such, the Casper City Council must approve all contracts and amendments, regardless of which municipality requested the study. This amendment will still allow the MPO to complete this project within the same federal fiscal year.

Oversight/Project Responsibility:

Beth Andress, MPO Supervisor, has been tasked with overseeing this project.

Attachments:

Resolution, Amendment No. 1 to Contract for Professional Services

**AMENDMENT NO. 1 TO THE CONTRACT
FOR PROFESSIONAL SERVICES (“AMENDMENT”)**

This Amendment to the Contract for Professional Services (“Amendment”) is entered into on this _____ day of May, 2023, by and between the following parties:

1. The City of Casper of Casper, Wyoming (“City”), a Wyoming municipal corporation, 200 North David Street, Casper, Wyoming 82601.
2. HDR Engineering, Inc., (“Consultant”), 601 Metz Drive, Gillette, Wyoming 82717.

Throughout this document, the City and the Consultant may be collectively referred to as the “parties.”

RECITALS

A. On December 6, 2022, the City and Consultant entered into a *Contract for Professional Services* (“Contract”) for the Casper Area Transit Electric Fleet Conversion Study.

B. In order to allow more time for public involvement, the completion deadline should be extended to June 30, 2023.

NOW, THEREFORE, in consideration of the mutual promises and covenants contained herein, the parties hereto agree by and between them to amend the Contract as follows:

1. INCORPORATION OF RECITALS

The recitals set forth above are hereby incorporated herein at this point as if fully set forth as part of this Amendment.

2. AMENDMENT TO PART I, SECTION 2, (TIME OF PERFORMANCE), PARAGRAPH B.

The paragraph which begins with “The Scope of Services listed in...” is deleted in its entirety and replaced with the following:

The Scope of Services described in Paragraph 1 shall be completed on or before June 30, 2023.

3. RATIFICATION

The terms and conditions of the Contract, as modified herein, are hereby ratified by the parties and shall remain in full force and effect.

IN WITNESS WHEREOF, the undersigned duly authorized representatives of the Parties have executed this Amendment as of the day and year above.

APPROVED AS TO FORM

Walter Tremel

ATTEST

CITY OF CASPER, WYOMING
A Municipal Corporation

Fleur Tremel
City Clerk

Bruce Knell
Mayor

WITNESS

CONSULTANT
HDR Engineering, Inc.

By: Elizabeth Coday
Printed Name: Elizabeth Coday
Title: Office Manager

By: Jason Kjenstad
Printed Name: Jason Kjenstad
Title: Sr. Vice President

RESOLUTION NO. 23-80

A RESOLUTION AUTHORIZING AMENDMENT NO. 1
TO THE CONTRACT FOR PROFESSIONAL SERVICES
BETWEEN THE CITY OF CASPER AND HDR
ENGINEERING

WHEREAS, on December 6, 2022, the City of Casper and HDR Engineering, Inc., entered into a Contract for Professional Services (“Contract”) in the amount of Ninety-Nine Thousand Nine Hundred Seventy-Three Dollars and Eleven Cents (\$99,973.11) for a Casper Are Transit Electric Fleet Conversion Study; and,

WHEREAS, the Contract was approved December 6, 2022, with a completion deadline of May 30, 2023; and,

WHEREAS in order to allow more time for public involvement, the deadline should be extended from May 30, 2023, to June 30, 2023.

NOW, THEREFORE, BE IT RESOLVED BY THE GOVERNING BODY OF THE CITY OF CASPER, WYOMING: That the Mayor is hereby authorized and directed to execute, and the City Clerk to attest, Amendment No. 1 to the above referenced Contract.

PASSED, APPROVED, AND ADOPTED on this ____ day of _____, 2023.

APPROVED AS TO FORM:



ATTEST:

CITY OF CASPER, WYOMING
A Municipal Corporation

Fleur Tremel
City Clerk

Bruce Knell
Mayor

April 20, 2023

MEMO TO: J. Carter Napier, City Manager 

FROM: Andrew Beamer, Public Services Director 
Cynthia Langston, Solid Waste Division Manager

SUBJECT: Authorizing a Contract for Professional Services with FORTERRA Concrete Products, Inc. in an amount of \$79,870 to manufacture 140 concrete blocks to be used for wind-blown litter and wood chips and fire spread prevention and product segregation at the Compost Yard within the Casper Regional Solid Waste Facility, Project No. 22-050.

Meeting Type & Date:

Regular Council Meeting, May 2, 2023

Recommendation:

That Council, by resolution, authorize a contract for professional services with FORTERRA Concrete Products, Inc. in an amount not to exceed \$79,870, to manufacture 140 concrete blocks to be utilized in the Compost Yard located within the Casper Regional Solid Waste Facility, Project No. 20-050.

Summary:

The existing compost yard located in the Casper Regional Solid Waste Facility provides finished products for sale. The customer drop-off and compost product production areas are surrounded by storm water ditches and frequently the wind blows grass, compost windrow materials, and completed natural and colored wood chips into the storm water ditches causing potential storm water contamination and cleanup work. To prevent storm water contamination, reduce cleanup labor, and prevent fire spread, staff recommends the purchase of 140 FORTERRA concrete blocks to create u-shape storage areas.

In 2017, City staff received quotes from other concrete block manufacturing companies and FORTERRA Concrete Products, Inc. was the only manufacturer in Wyoming and provided the lowest cost per block pricing. In addition, FORTERRA's manufacturing facility is located in Bar Nunn, Wyoming, and no transportation fees are required.

FORTERRA agreed to a 5.26% increase in pricing from the \$542 per block price in 2018, \$570.50 per block. Staff recommends awarding FORTERRA Concrete Products, Inc., a professional services contract to manufacture 140 concrete blocks in an amount of \$79,870.

Financial Considerations

Funding from Balefill Fund Reserves and included in the Balefill FY23 budget, GL Account 2060044-6255.

Oversight/Project Responsibility

Sean Orszulak, Solid Waste Superintendent/Mike Bratvold, Transfer Station & Special Waste Supervisor

Attachments

FORTERRA Concrete Products, Inc. Contract for Professional Services

Exhibit A – FORTERRA specifications for Casper Compost Yard Concrete Blocks

CONTRACT FOR PROFESSIONAL SERVICES

PART I - AGREEMENT

This Contract for Professional Services ("Contract") is entered into on this 02 day of May 2023, by and between the following parties:

1. The City of Casper, Wyoming, a Wyoming municipal corporation, 200 North David Street, Casper, Wyoming 82601 ("City").
2. FORTERRA Concrete Products, Inc., 2175 West Winds, Bar Nunn, Wyoming 82601 ("Contractor").

Throughout this document, the City and the Contractor may be collectively referred to as the "parties."

RECITALS

A. The City is undertaking a project to improve operations and fire control measures within the compost yard by separating compost yard materials from storm water ditches and within concrete bin blocks.

B. The project requires professional services for the manufacturing of concrete bin blocks for the City to use in its compost products yard.

C. The Contractor represents that it is ready, willing, and able to provide the professional services to City as required by this Contract.

D. The City desires to retain the Contractor for such services.

NOW, THEREFORE, in consideration of the covenants and conditions set forth herein to be performed, the parties agree as follows:

1. SCOPE OF SERVICES:

The Contractor shall perform the following services in connection with and respecting the project as described below, and in accordance with Exhibit A, which is hereby made a part of the Contract.

- A. Manufacture 140 concrete blocks for the City's compost yard.
- B. The concrete blocks shall be manufactured to be two feet (2') wide, two feet (2') deep and nine feet eight inches (9'8") long as specified in Exhibit A.

C. As blocks are manufactured, Contractor shall communicate with the City designated contact, Special Waste Supervisor, to arrange pickup and transport of the blocks to the City's compost yard.

2. TIME OF PERFORMANCE:

The services of the Contractor shall be undertaken and completed on or before the 30th day of December 2023.

3. COMPENSATION:

In consideration of the performance of services rendered under this Contract, the Contractor shall be compensated for services performed in accordance with paragraph 1, not to exceed a sum of Seventy-Nine Thousand Eight Hundred Seventy and 00/100 Dollars (\$79,870).

4. METHOD OF PAYMENT:

Payment will be made following completion of the terms set forth herein and receipt of an itemized invoice, certified under penalty of perjury, from the Contractor for services rendered in conformance with the Contract, and following approval by the Casper City Council. The invoice for payment must specify the correct amount due; that the Contractor has performed the services rendered under this Contract, in conformance with the Contract, and that it is entitled to receive the amount requested under the terms of the Contract.

If amounts owed by the Contractor to the City for any goods, services, licenses, permits or any other items or purpose remain unpaid beyond the City's general credit policy, those amounts may be deducted from the payment being made by the City to the Contractor pursuant to this Contract.

5. TERMS AND CONDITIONS:

This Contract is subject to and incorporates the provisions attached hereto as PART II -- GENERAL TERMS AND CONDITIONS.

6. EXTENT OF CONTRACT:

This Contract represents the entire and integrated Agreement between the City and the Contractor, and supersedes all prior negotiations, representations, or agreements, either written or oral. The Contract may be amended only by written instrument signed by both the City's and the Contractor's authorized representatives.

The City and the Contractor each individually represent that they have the requisite authority to execute this Contract and perform the services described in this Contract.

IN WITNESS WHEREOF, the undersigned duly authorized representatives of the parties have executed this Contract as of the day and year above.

APPROVED AS TO FORM

Walter Tremel

ATTEST

CITY OF CASPER, WYOMING
A Municipal Corporation

Fleur Tremel
City Clerk

Bruce Knell
Mayor

WITNESS

CONTRACTOR
FORTERRA Concrete Products, Inc.

By: _____

DocuSigned by:
By: Shane Conley
8C300C62BBCE4A2

Printed Name: _____

Printed Name: Shane Conley

Title: _____

Title: Sales Manager

CONTRACT FOR PROFESSIONAL SERVICES

PART II - GENERAL TERMS AND CONDITIONS

1. TERMINATION OF CONTRACT:

1.1 The City may terminate this Contract anytime by providing thirty (30) days written notice to Contractor of intent to terminate said Contract. In such event, all finished or unfinished documents, data, studies and reports prepared by the Contractor under this Contract shall, at the option of the City, become its property, and the Contractor shall be entitled to receive just and equitable compensation for any satisfactory work completed on such documents.

1.2 Notwithstanding the above, the Contractor shall not be relieved of liability to the City for damages sustained by the City, by virtue of termination of the Contract by Contractor, or any breach of the Contract by the Contractor, and the City may withhold any payments to the Contractor for the purpose of setoff until such time as the exact amount of damages due the City from the Contractor are determined.

2. CHANGES:

The City may, from time to time, request changes in the scope of the services of the Contract. Such changes, including any increase or decrease in the amount of the Contractor's compensation, which are mutually agreed upon between the City and the Contractor, shall be incorporated in written amendments to this Contract. There shall be no increase in the amount of Contractor's compensation unless approved by Resolution adopted by City.

3. ASSIGNABILITY:

The Contractor shall not assign any interest in this Contract, and shall not transfer any interest in the same (whether by assignment or novation) without the prior written approval of the City; provided, however, that claims for money due or to become due to the Contractor from the City under this Contract may be assigned to a bank, trust company, or other financial institution, or to a trustee in bankruptcy, without such approval. Notice of any assignment or transfer shall be furnished to the City within five (5) business days of any assignment or transfer.

4. AUDIT:

The City and its representatives shall have access and obtain at its discretion, copies to any books, documents, papers, electronic data and records of the Contractor, which are pertinent to this Contract. The Contractor shall immediately, upon receiving written instruction from the City, provide to any independent auditor or accountant all books,

documents, papers, electronic data and recordings of the Contractor which are pertinent to this Contract. The Contractor shall cooperate fully with any such independent auditor or accountant during the entire course of any audit authorized by the City.

5. EQUAL EMPLOYMENT OPPORTUNITY:

In carrying out the program, the Contractor shall not discriminate against any employee or applicant for employment because of race, color, religion, sex, national origin, or disability. The Contractor shall take affirmative action to ensure that applicants for employment are employed, and that employees are treated during employment, without regard to their race, color, religion, sex, national origin, or disability. Such action shall include, but not be limited to, the following: employment upgrading, demotion, or transfer; recruitment or recruitment advertising; layoff or termination; rates of pay or other forms of compensation; and selection for training, including apprenticeship. The Contractor shall post in conspicuous places, available to employees and applicants for employment, notices required by the government setting forth the provisions of this nondiscrimination clause. The Contractor shall state that all qualified applicants will receive consideration for employment without regard to race, color, religion, sex, national origin, or disability.

6. OWNER OF PROJECT MATERIALS:

All finished or unfinished documents, data, studies, surveys, drawings, maps, models, photographs, films, duplicating plates, and reports prepared by the Contractor under this Contract shall be considered the property of the City, and upon completion of the services to be performed, or termination of this Contract, they will be turned over to the City provided that, in any case, the Contractor may, at no additional expense to the City, make and retain such additional copies thereof as Contractor desires for its own use; and provided further, that in no event may any of the documents, data, studies, surveys, drawings, maps, models, photographs, films, duplicating plates, or other reports retained by the Contractor be released to any person, agency, corporation, or organization without the written consent of the City.

7. FINDINGS CONFIDENTIAL:

All reports, information, data, etc., given to or prepared, or assembled by the Contractor under this Contract are confidential and shall not be made available to any individual or organization by the Contractor without the prior written consent of the City.

8. GOVERNING LAW AND VENUE:

This Contract shall be governed by the laws of the State of Wyoming. The Courts of the State of Wyoming shall have jurisdiction over this Contract and the parties. The venue shall be the Seventh Judicial District, Natrona County, Wyoming. The Contractor shall also comply with all applicable laws, ordinances, and codes of the local, state, or federal.

governments and shall not trespass on any public or private property in performing any of the work embraced by this Contract.

9. PERSONNEL:

The Contractor represents that it has, or will secure, all personnel required in performing the services under this Contract. Such personnel shall not be employees of the City. All of the services required shall be performed by the Contractor, or under its supervision, and all personnel engaged in the work shall be fully qualified. All personnel employed by Contractor shall be employed in conformity with applicable local, state or federal laws.

10. SUBCONTRACTOR:

The Contractor shall not employ any subcontractor to perform any services in the scope of this project, unless the subcontractor is approved in writing by the City. Any approved subcontractor shall be paid by the Contractor.

11. INSURANCE AND INDEMNIFICATION:

A. **Prior to the commencement of work**, Contractor shall procure and maintain for the duration of the Contract insurance against claims for injuries to persons or damages to property which may arise from or in connection with the performance of the work hereunder by the Contractor, its subcontractors, agents, representatives, or employees.

B. *Minimum Scope and limit of Insurance.*

Coverage shall be at least as broad as:

1. Commercial General Liability (CGL): Insurance Services Office Form CG 00 01 covering CGL on an "occurrence" basis, including products and completed operations, property damage, bodily injury and personal & advertising injury with limits no less than the sum of Two Hundred Fifty Thousand Dollars (\$250,000) to any claimant for any number of claims arising out of a single transaction or occurrence, or the sum of Five Hundred Thousand Dollars (\$500,000) for all claims arising out of a single transaction or occurrence. If a general aggregate limit applies, the general aggregate limit shall apply separately to this project/location (ISO CG 25 03 or 25 04) or the general aggregate limit shall be twice the required occurrence limit). The CGL policy shall be endorsed to contain Employers Liability/Stop Gap Coverage
2. Automobile Liability: Insurance Services Office Form Number CA 0001 covering Code 1 (any auto), or if Contractor has no owned autos, Code 8 (hired) and 9 (non-owned), with limit no less than Five Hundred Thousand (\$500,000) per accident for bodily injury and property damage.

3. Workers' Compensation: as required by the State of Wyoming with Statutory Limits.

4. Professional Liability (Errors and Omissions) Insurance appropriate to the Contractor's profession, with limit no less than the sum of Two Million Dollars (\$2,000,000) to any claimant for any number of claims arising out of a single transaction or occurrence; or the sum of Two Million Dollars (\$2,000,000) for all claims arising out of a single transaction or occurrence. If a general aggregate limit applies, the general aggregate limit shall apply separately to this project/location.

C. *Higher Limits.* If the Contractor maintains broader coverage and/or higher limits than required under this Agreement, then the City shall be entitled to the broader coverage and/or the higher limits maintained by the Contractor. Any available insurance proceeds in excess of the specified minimum limits of insurance and coverage shall be available to the City.

D. *Other Insurance Provisions*

The insurance policies are to contain, or be endorsed to contain, the following provisions:

1. *Additional Insured Status*

The City, its officers, elected and appointed officials, employees, agents and volunteers are to be covered as additional insureds on the CGL policy with respect to liability arising out of work or operations performed by or on behalf of the Contractor including materials, parts, or equipment furnished in connection with such work or operations. General liability coverage shall be provided in the form of an endorsement to the Contractor's insurance (at least as broad as ISO Form CG 20 10 11 85 or both CG 20 10, CG 20 26, CG 20 33, or CG 20 38 and CG 20 37 forms if later revisions used).

2. *Primary Coverage*

For any claims related to this Contract, the Contractor's insurance coverage shall be primary and non-contributory insurance coverage at least as broad as ISO CG 20 01 04 13 as respects the Contractor as respects the City, its officers, elected and appointed officials, employees, agents and volunteers.

3. *Notice of Cancellation*

Each insurance policy required above shall state that coverage shall not be canceled, materially changed, or reduced, except with notice to the City. Such notice to the City shall be provided in a commercially reasonable time.

4. *Waiver of Subrogation*

Contractor hereby grants to City a waiver of any right to subrogation which any insurer of said Contractor may acquire against the City by virtue of the payment of any loss under such insurance. Contractor agrees to obtain any endorsement that may be necessary to affect this waiver of subrogation, but this provision applies regardless of whether or not the City has received a waiver of subrogation endorsement from the insurer.

5. *Deductibles and Self-Insured Retentions*

Contractor has two options regarding deductibles and self-insured retentions:

- a. Option 1: Any deductibles or self-insured retentions must be declared to and approved by the City. Unless otherwise approved by the City in writing, any deductible may not exceed Ten Thousand Dollars (\$10,000). Unless otherwise approved in writing by the City, self-insured retentions may not exceed Ten Thousand Dollars (\$10,000), and the City may require the Contractor to provide proof of ability to pay losses and related investigations, claim administration, and defense expenses within the retention.
- b. Option 2: Contractor shall carry insurance with terms that require its insurance company to pay the full value of a covered claim from the first dollar of coverage, even if the Contractor is unable to pay any deductible or self-insured retention amount(s) required by the insurance policy. Contractor shall provide a written endorsement from its insurance carrier that such insurance coverage is in place, and shall keep such coverage in place during the term of this Contract and any subsequent time period required for claims made policies.

6. *Acceptability of Insurers*

Insurance is to be placed with insurers with a current A.M. Best's rating of no less than A:VII, unless otherwise agreed to in writing by the City.

7. *Claims Made Policies*

If any of the required policies provide coverage on a claims-made basis:

- a. The Retroactive Date must be shown and must be before the date of the Contract or the beginning of Contract work.
- b. Insurance must be maintained and evidence of insurance must be provided *for at least five (5) years after completion of the contract of work*. However, Contractor's liabilities under this Contract shall not be deemed limited in any way by the insurance coverage required.

- c. If coverage is canceled or non-renewed, and not *replaced with another claims-made policy form with a Retroactive Date* prior to the Contract effective date, the Contractor must purchase "extended reporting" coverage for a minimum of *five (5) years* after completion of contract work and at all times thereafter until the applicable statute of limitations runs.

8. *Verification of Coverage*

Contractor shall furnish the City with original certificates of insurance including all required amendatory endorsements or copies of the applicable policy language effecting coverage required by this clause and a copy of the Declarations and Endorsement Page of the CGL policy listing all policy endorsements to the City before work begins. All certificates and endorsements are to be received and approved by the City before work commences. However, failure to obtain the required documents prior to the work beginning shall not waive the Contractor's obligation to provide them. The City reserves the right to require complete, certified copies of all required insurance policies, including endorsements required by these specifications, at any time.

9. *Subcontractors*

Contractor shall require and verify that all subcontractors maintain insurance meeting all the requirements stated herein, and Contractor shall ensure that the City is an additional insured on insurance required from subcontractors.

10. *Special Risks or Circumstances*

City reserves the right to reasonably modify these requirements, including limits, based on the nature of the risk, prior experience, insurer, coverage, or other special circumstances.

- E. Contractor agrees to indemnify the City, the City's employees, elected officials, appointed officials, agents, and volunteers, and all additional insured and hold them harmless from all liability for damages to property or injury to or death to persons, including all reasonable costs, expenses, and attorney's fees incurred related thereto, to the extent arising from negligence, fault or willful and wanton conduct of the Contractor and any subcontractor thereof.

12. LIMITATION OF LIABILITY:

In no event shall the City, the City's employees, elected officials, appointed officials, or agents be liable under this Contract to Contractor or any third party for consequential, indirect, incidental, special, exemplary, punitive or enhanced damages or lost profits or revenues, or diminution in value, arising out of, relating to, or in connection with any breach of this Contract, regardless of (a) whether such damages were foreseeable (b) whether or not the Contractor was advised of the possibility of such damages and (c) the legal or equitable theory (contract, tort, or otherwise) upon which the claim is based.

13. INTENT:

Contractor represents that it has read and agrees to the terms of this Contract and further agrees that it is the intent of the parties that Contractor shall perform all of the services for the compensation set forth in this Contract. Contractor also agrees that it is the specific intent of the parties, and a material condition of this Contract, that it shall not be entitled to compensation for other services rendered unless specifically authorized by the City by Resolution of its governing body. Contractor agrees that it has carefully examined the Scope of Services, and that the compensation is adequate for performance of this Contract.

14. WYOMING GOVERNMENTAL CLAIMS ACT:

The City does not waive any right or rights it may have pursuant to the Wyoming Governmental Claims Act, Wyoming Statutes Section 1-39-101 et seq., and the City specifically reserves the right to assert any and all rights, immunities, and defenses it may have pursuant to the Wyoming Governmental Claims Act.

15. NO THIRD PARTY BENEFICIARY RIGHTS:

The parties to this Contract do not intend to create in any other individual or entity the status of third-party beneficiary, and this Contract shall not be construed so as to create such status. The rights, duties and obligations contained in this Contract shall operate only between the parties to this Contract, and shall inure solely to the benefit of the parties to this Contract. The parties to this Contract intend and expressly agree that only parties signatory to this Contract shall have any legal or equitable right to seek to enforce this Contract, to seek any remedy arising out of a party's performance or failure to perform any term or condition of this Contract, or to bring an action for the breach of this Contract.

16. FORCE MAJEURE:

Neither party shall be liable for failure to perform under this Contract if such failure to perform arises out of causes beyond the control and without the fault or negligence of the nonperforming party. Such causes may include, but are not limited to, acts of God or the public enemy, fires, floods, epidemics, pandemics, quarantine restrictions, freight embargoes, and unusually severe weather. This provision shall become effective only if the party failing to perform immediately notifies the other party of the extent and nature of the problem, limits delay in performance to that required by the event, and takes all reasonable steps to minimize delays.

17. ELECTRONIC SIGNATURES:

The parties understand and agree that they have the right to execute this Contract through paper or through electronic signature technology, which is in compliance with Wyoming

and federal law governing electronic signatures. The parties agree that to the extent they sign electronically, their electronic signature is the legally binding equivalent to their handwritten signature. Whenever they execute an electronic signature, it has the same validity and meaning as their handwritten signature. They will not, at any time in the future, repudiate the meaning of their electronic signature or claim that their electronic signature is not legally binding. They agree not to object to the admissibility of this Contract as an electronic record, or a paper copy of an electronic document, or a paper copy of a document bearing an electronic signature, on the grounds that it is an electronic record or electronic signature or that it is not in its original form or is not an original. Each party will immediately request that their electronic signature be revoked in writing if they discover or suspect that it has been or is in danger of being lost, disclosed, compromised or subjected to unauthorized use in any way. If either party would like a paper copy of this Contract, they may request a copy from the other party, and the other party shall provide it.

EXHIBIT A - FORTERRA SPECIFICATIONS

for Casper Compost Yard Concrete Blocks

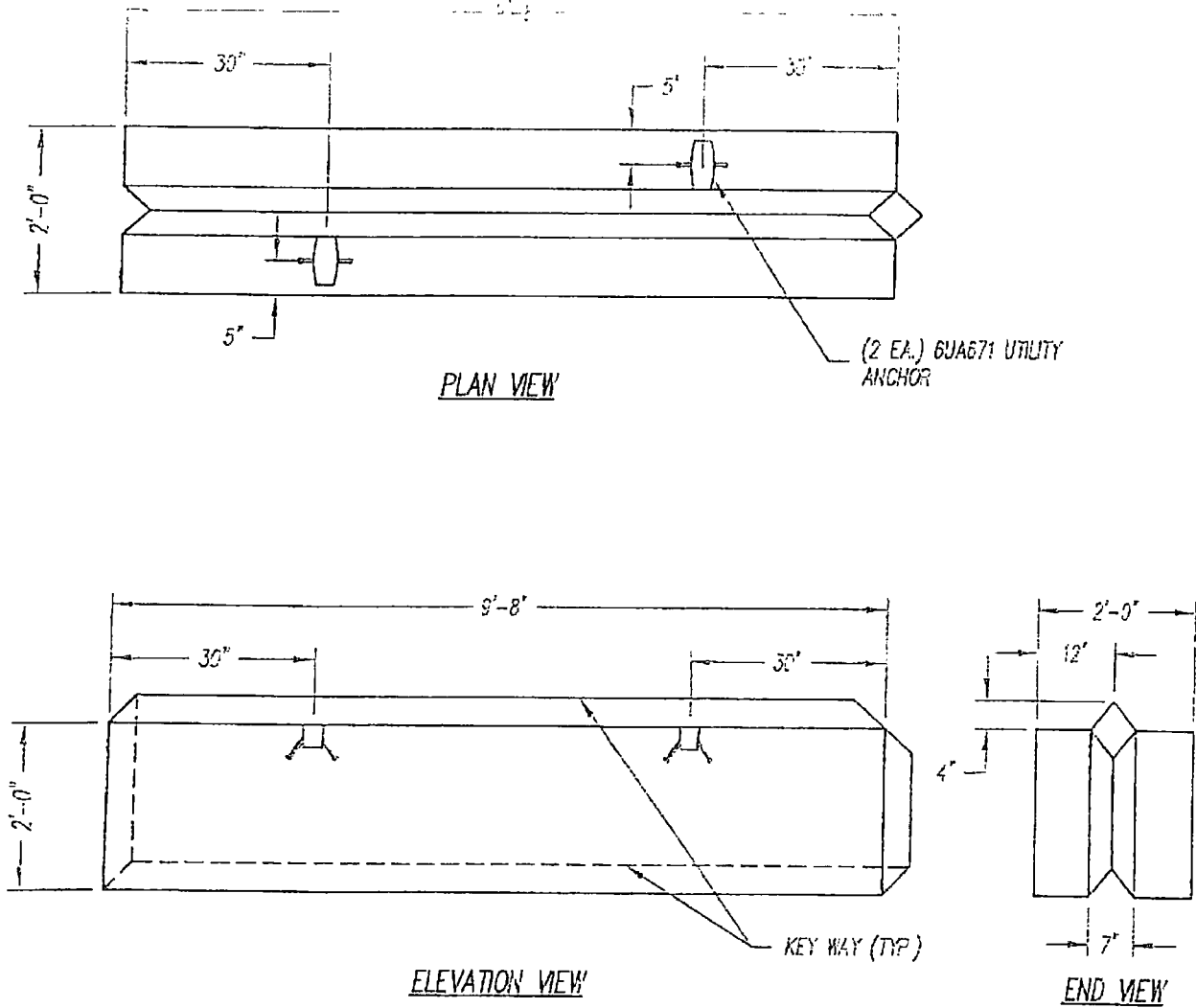

Date Cast _____

Set up _____

Pre Pour _____

Post Pour _____

Date _____

WEIGHT = 5,802 LBS



FORTERRA

MARCK

OFFICES IN:

HELENA

RAPID CITY

SCALE NONE

DATE 6/12/13

DR'N BY TDE

TITLE

2' X 2' X 9'-8" BIN BLOCKS
CITY OF CASPER WASTE FACILITY
CASPER, WY

RSE 753210

CUSTOMER CITY OF CASPER

REV DATE -

DWG NAME 753210-01

PROPRIETARY AND CONFIDENTIAL
THE INFORMATION CONTAINED IN THIS DRAWING IS THE
SOLE PROPERTY OF CRETEX CONCRETE PRODUCTS, INC.
ANY REPRODUCTION, IN PART OR AS A WHOLE,
WITHOUT THE WRITTEN PERMISSION OF CRETEX
CONCRETE PRODUCTS, INC. IS PROHIBITED

- NOTES:
1. MIN. CONCRETE STRENGTH = 4,000 PSI
 2. BLOCKS ARE UN-REINFORCED.

RESOLUTION NO. 23-81

A RESOLUTION AUTHORIZING A CONTRACT FOR PROFESSIONAL SERVICES WITH FORTERRA CONCRETE PRODUCTS, INC., FOR MANUFACTURING CONCRETE BLOCKS TO BE USED AT THE CASPER COMPOST YARD, PROJECT NO. 22-050.

WHEREAS, the City of Casper desires to enter into a contract for professional services with FORTERRA to manufacture concrete blocks to be used at the Casper Compost Yard where customer drop off yard debris and compost products are created; and,

WHEREAS, FORTERRA Concrete Products, Inc., is able and willing to provide those services, specified as Compost Yard Concrete Blocks, Project No. 22-050.

NOW, THEREFORE, BE IT RESOLVED BY THE GOVERNING BODY OF THE CITY OF CASPER, WYOMING: That the Mayor is hereby authorized and directed to execute, and the City Clerk to attest, a Contract for Professional Services with FORTERRA Concrete Products, Inc. to provide professional manufacturing services for the Casper Compost Yard within the Casper Regional Solid Waste Facility, Project No. 22-050.

BE IT FURTHER RESOLVED: That the City Manager is hereby authorized to make verified partial payments as set forth in said Agreement with funds from the Balefill Cost Center not to exceed the sum of Seventy-Nine Thousand Eight Hundred Seventy and 00/100 Dollars (\$79,870.00).

PASSED, APPROVED, AND ADOPTED this ____ day of _____, 2023.

APPROVED AS TO FORM:



ATTEST:

Fleur D. Tremel
City Clerk

CITY OF CASPER, WYOMING
A Municipal Corporation

Bruce Knell
Mayor

April 20, 2023

MEMO TO: J. Carter Napier, City Manager *JCN*

FROM: Andrew Beamer, P.E., Public Services Director *AB*
Zulima Lopez, Parks, Recreation, and Public Facilities Director
Alex Sveda, P.E., City Engineer *AS*

SUBJECT: Authorizing an Agreement with LER, Inc., dba Renner Sports Surfaces, in the amount of \$98,000, for the Highland Park Pickleball Court Resurfacing, Project No. 23-013.

Meeting Type & Date:
Regular Council Meeting
May 2, 2023

Action Type:
Resolution

Recommendation:
That Council, by Resolution, authorize an Agreement with LER, Inc., dba Renner Sports Surfaces (Renner), for the Highland Park Pickleball Court Resurfacing, Project No. 23-013, in the amount of \$110,000, with deduct Change Order No. 1 (CO1), in the amount of \$12,000.00, for a revised contract amount of \$98,000. Furthermore, it is recommended that Council authorize a construction contingency account, in the amount of \$5,000, for a total project amount of \$103,000.

Summary:
In June of 2022, the City and the Natrona County School District (NCSD) entered into a Memorandum of Understanding (MOU) to develop 4.57-acres of Highland Park into a ten-court tennis complex with bleachers and tiered seating. The property has been transferred by warranty deed to NCSD where the MOU requires ongoing maintenance by NCSD and where existing City utility easement rights are retained. Also as part of the MOU, the City agreed to resurface the remaining two northern-most tennis courts at Highland Park and convert them to pickleball courts.

On April 7, 2023, the City of Casper received one (1) bid for the Highland Park Pickleball Court Resurfacing, Project No. 23-013. The bid received is as follows:

Contractor	Location	Total Base Bid
LER, Inc., dba Renner Sports Surfaces	Denver, Colorado	\$110,000.00

The project includes converting the two northern-most tennis courts into standard pickleball

courts at Highland Park along South Beverly Street. The work includes cleaning, repairing, resurfacing, restriping, netting, and 4-foot tall fencing.

The Engineer's estimate provided by the City of Casper was \$79,000. The cost difference accounts for higher pricing from suppliers for the netting and related hardware where the estimate was \$4,000 and the bid item was \$36,000.

As a result of the bid, City Staff worked with Renner to reduce costs for each bid item with a time extension, all as part of CO1. CO1 includes a deduct in the amount of \$12,000 and a time extension for substantial completion to July 1, 2024 (or 282 calendar days). Costs. City Staff have reviewed the bid and CO1 and recommend that Renner be awarded work, for a total amount of \$98,000.

The work is scheduled to be substantially completed by July 1, 2024.

Financial Considerations:

Funding for this project will be \$115,000 from Opportunity Funds.

Oversight/Project Responsibility:

Alex Sveda, P.E., City Engineer

Attachments:

Resolution

Agreement

CO1

STANDARD FORM OF
AGREEMENT BETWEEN OWNER AND CONTRACTOR

THIS AGREEMENT is made between the City of Casper, 200 North David Street, Casper, Wyoming 82601, hereinafter referred to as the "Owner," and LER, Inc., dba Renner Sports Services, 2775 West 7th Avenue, Denver, Colorado 80204.

WHEREAS, the City of Casper desires cleaning, repairing, resurfacing, striping, and converting, complete, two (2) existing tennis courts to pickleball courts with all amenities included nets, posts, fencing and gates, all located at 630 South Beverly Street, Casper, Wyoming;

WHEREAS, the Contractor is able and willing to provide those services specified as the

Highland Park Pickleball Court Resurfacing, Project No. 23-013

NOW, THEREFORE, it is hereby agreed as

follows: ARTICLE 1. WORK.

Contractor shall perform all the work required by the Contract Documents for the Highland Park Pickleball Court Resurfacing, Project No. 23-013, hereinafter referred to as the "Work."

ARTICLE 2. ARCHITECT/ENGINEER.

The Project has been designed by the City of Casper, who is hereinafter referred to as the "Engineer" and who is to act as Owner's representative, assume all duties and responsibilities and have the rights and authority assigned to Architect and/or Engineer in the Contract Documents in connection with completion of the Work in accordance with the Contract Documents.

ARTICLE 3. CONTRACT TIME.

- 3.1 The Work will be substantially completed by **July 1, 2024**, and ready for final payment in accordance with Article 14 of the General Conditions by **July 8, 2024**. Substantial Completion will be accepted once all utilities are installed and in working order, surfacing is replaced and the project site is returned to full normal vehicular and pedestrian traffic. Once Contractor has mobilized on-site and work has commenced, Contractor shall work continuously on-site, during the construction activities hours specified in these contract documents, until work is substantially complete. Contractor shall submit a comprehensive traffic control plan. No open excavations shall remain overnight.
- 3.2 Liquidated Damages. Owner and Contractor recognize that time is of the essence of this Agreement and that Owner will suffer financial loss if the Work is not substantially completed by the time specified in Paragraph 3.1 above, plus any extension thereof allowed in accordance with Article 12 of the General Conditions. They also recognize the delays, expense, and difficulties involved in proving in a legal or arbitration proceeding the actual loss suffered by Owner if the Work is not substantially completed on time. Accordingly, instead of requiring any such proof, Owner and Contractor agree that as liquidated damages

for delay (but not as a penalty) Contractor shall pay Owner One Thousand Dollars (\$1,000.00) for each day that expires after the time specified in Paragraph 3.1 for substantial completion. After Substantial Completion, if Contractor shall neglect, refuse, or fail to complete the remaining work within the time specified in paragraph 3.1 for completion and readiness for final payment or any proper extension thereof granted by Owner, Contractor shall pay Owner Five Hundred Dollars (\$500.00) for each day that expires after the time specified in paragraph 3.1 for completion and readiness for final payment. It is further agreed that such liquidated damages are not a penalty, but represent the parties' best estimate of actual damages.

ARTICLE 4. CONTRACT PRICE.

In Consideration of the performance of the work in accordance with the Contract documents for this Unit Price Contract, Owner shall pay Contractor in current funds a not-to-exceed total contract price of Ninety-Eight Thousand and 00/100 Dollars (\$98,000.00), subject to additions and deductions by Change Order approved by the Owner. The contract fee shall be based on materials actually furnished and installed and services actually provided based on the lump sum price for the Base Bid.

ARTICLE 5. PAYMENT PROCEDURES.

Contractor shall submit Applications for Payment in accordance with Article 14 of the General Conditions. Applications for Payment will be processed through the Engineer as provided in the General Conditions.

5.1 Progress Payments. Contractor's Applications for Payment, as recommended by Engineer, shall be submitted to accounts payable@Casperwy.gov AND City Engineering Staff on or before the 25th day of each month during construction, and Owner shall mail progress payments in the following month one day after the second monthly meeting of the Casper City Council. Progress payments shall be structured as provided below. All progress payments will be on the basis of the progress of the Work measured by the Schedule of Values provided for in Paragraph 14.01 of the General Conditions, subject to the cutoff and submittal dates provided in the Measurement and Payment Procedures.

5.1.1 Progress payments will be made in an amount equal to ninety-five percent (95%) of the Work completed, and ninety-five percent (95%) of Invoice Cost of materials and equipment not incorporated in the Work but delivered and suitably stored, less in each case the aggregate of payments previously made in order to withhold such amounts where retainage is equal to five percent (5%) of any work completed throughout project and of the Total Contract Price.

5.1.2 In the event the Contractor makes only one application for payment upon substantially completing the Work, progress payment will be made in an amount equal to ninety-five percent (95%) of the Work completed. Owner shall withhold five percent (5%) of the work completed as retainage, said retainage to be paid in accordance with the provisions of Paragraph 5.3, Final Payment.

5.1.3 Should amounts owed by the Contractor to the City for any goods, services,
SFA-2

licenses, permits or any other item or purpose remain unpaid beyond the City's general credit policy, those amounts may be deducted from the payment being made by the City to the Contractor pursuant to this agreement.

- 5.2 OWNER may withhold progress payments if CONTRACTOR fails to submit an updated progress schedule with the application for payment as detailed in Section 01310 Progress Schedules.
- 5.3 Final Payment. Upon final completion and acceptance of the Work in accordance with Paragraph 14.13 of the General Conditions, Engineer shall recommend payment and present Contractor's Final Application for Payment to the City. Pursuant to Wyoming State Statutes, final payment cannot be made until forty-one (41) days after publication of the first Notice of Completion.

ARTICLE 6. WITHHELD FUNDS.

Pursuant to Wyoming Statutes Section 16-6-701 *et seq.*, withheld percentages for Contracts exceeding Thirty-Five Thousand Dollars (\$35,000.00) will be retained in an account in the name of the Contractor (except when specifically waived in writing by Contractor) which has been assigned to the Owner until the Contract is completely, satisfactorily, and finally accepted by the Owner. Unless a depository is designated by the Contractor in a written attachment hereto, the Contractor's signature hereon shall act as authority for the Owner to designate a retainage depository on behalf of the Contractor, for the purposes specified in Wyoming Statutes Section 16-6-704. The Contractor's signature hereon shall act as an assignment of the depository account to the Owner, as provided by Wyoming Statutes Section 16-6-701 *et seq.*, whether the depository is designated by the Contractor or by the Owner.

ARTICLE 7. CONTRACTOR'S REPRESENTATIONS.

In order to induce Owner to enter into this Agreement, Contractor makes the following representations:

- 7.1 Contractor has familiarized himself with the nature and extent of the Contract Documents, Work, locality, and with all local conditions and federal, state, and local Laws and Regulations that in any manner may affect cost, progress, or performance of the Work.
- 7.2 Contractor has studied carefully all reports of investigations and tests of subsurface and latent physical conditions at the site or otherwise affecting cost, progress, or performance of the work which were relied upon by Engineer in the preparation of the Drawings and Specifications and which have been identified in the Supplementary Conditions.
- 7.3 Contractor has made or caused to be made examinations, investigations, and tests and studies as he deems necessary for the performance of the Work at the Contract Price, within the Contract Time, and in accordance with the other terms and conditions of the Contract Documents; and no additional examinations, investigations, tests, reports, or similar data are or will be required by Contractor for such purposes.
- 7.4 Contractor has correlated the results of all such observations, examinations, investigations, tests, reports, and data with the terms and conditions of the Contract Documents.

7.5 Contractor has given Engineer written notice of all conflicts, errors, or discrepancies that he has discovered in the Contract Documents and the written resolution thereof by Engineer is acceptable to Contractor.

ARTICLE 8. CONTRACT DOCUMENTS.

The Contract Documents which comprise the entire agreement between Owner and Contractor are attached to this Agreement, made a part hereof and consist of the following:

- 8.1 This Agreement (Pages SFA-1 to SFA-6, inclusive).
- 8.2 Joint Account Agreement or Letter of Forfeiture waiving same.
- 8.3 Exhibit "A" - Bid Form (BF-1 through BF-4 of the Bid Form and the Bid Schedule.
- 8.4 Addenda: Addendum No. 1, Addendum No. 2, Addendum No. 3, and Addendum No. 4.
- 8.5 Performance and Payment Bonds.
- 8.6 Certificates of Insurance, of Workers' Compensation Coverage, and of Unemployment Insurance Coverage.
- 8.7 General Conditions (Pages 00700-1 to 00700-42, inclusive).
- 8.8 Supplementary Conditions (Pages SC-1 to SC-16, inclusive).
- 8.9 General Requirements, consisting of Nine (9) sections. Special Provisions consisting of One (1) Section and Three (3) Drawing "Sheets".
- 8.10 Notice of Award.
- 8.11 Notice to Proceed.
- 8.12 Minutes of the Pre-Bid Conference, if any.
- 8.13 Contract Drawings, with each sheet bearing the following general title:

Highland Park Pickleball Court Resurfacing, Project No. 23-013
- 8.14 Shop Drawings and other Submittals furnished by Contractor during performance of the Work and accepted by the Owner.
- 8.15 Any modifications, amendments, and supplements, including Change Orders, issued pursuant to Paragraphs 3.04 and 3.05 of the General Conditions, on or after the effective date of this Agreement.
- 8.16 Notice of Substantial Completion.

8.17 Change Order No. 1

ARTICLE 9. GOVERNMENTAL CLAIMS ACT.

The City does not waive any right or rights it may have pursuant to the Wyoming Governmental Claims Act, Wyoming Statutes Section 1-39-101 et seq. The City specifically reserves the right to assert any and all immunities, rights, and defenses it may have pursuant to the Wyoming Governmental Claims Act.

ARTICLE 8. MISCELLANEOUS PROVISIONS.

Terms used in this Agreement, which are defined in the General Conditions, shall have the meanings designated in those conditions.

IN WITNESS WHEREOF, the parties hereto have caused this Agreement to be executed in
one
(1) original copy on the day and year below written.

DATED this _____ day of _____, 2023.

*****THE REMAINDER OF THIS PAGE IS INTENTIONALLY LEFT BLANK*****

APPROVED AS TO FORM:

(Highland Park Pickleball Court Resurfacing, Project No. 23-013)

Walter Tremel

ATTEST:

By: _____

Title: _____

ATTEST:

By: _____

Title: Fleur Tremel
City Clerk

CONTRACTOR:

By: _____

Title: _____

OWNER:
CITY OF CASPER, WYOMING
A Municipal Corporation

By: _____

Title: Bruce Knell
Mayor

EXHIBIT "A"
STANDARD
BID FORM
(Approved by City Attorney, 1995)

PROJECT IDENTIFICATION: City of Casper
Highland Park Pickleball Court Resurfacing
Project No. 23-013

THIS BID SUBMITTED TO: City of Casper
200 North David Street
Casper, Wyoming 82601

1. The undersigned Bidder proposes and agrees, if this Bid is accepted, to enter into an Agreement with the City in the form included in the Bidding Documents and to complete all Work by September 22, 2023 as specified or indicated in the Bidding Documents for the Contract Price, and completed and ready for final payment not later than by September 29, 2023, in accordance with the Bidding Documents.
2. Bidder accepts all of the terms and conditions of the Advertisement for Bids and Instructions to Bidders, including without limitation those dealing with the disposition of Bid Guaranty. This Bid will remain effective for thirty (30) days after the day of Bid opening. Bidder will sign the Agreement and submit the Bonds and other documents required by the Bidding Documents within thirty (30) days after the date of the City's Notice of Award.
3. Notice that preferences will be granted pursuant to Wyoming Statutes Section 16-6-101, et seq., is hereby acknowledged.
4. In submitting this Bid, Bidder represents, as more fully set forth in the Bidding Documents, that:
 - A. Bidder has examined copies of all the Bidding Documents and of the following addenda (receipt of all which is hereby acknowledged):

Addendum No. <u>1</u>	Dated <u>see attached</u>
Addendum No. <u>2</u>	Dated _____
<u>3</u>	
 - B. Bidder has examined the site and locality where the work is to be performed, the federal, state, and local Laws and Regulations, and the conditions affecting cost, progress, or performance of the work and has made such independent investigations as Bidder deems necessary;

C. This Bid is genuine and not made in the interest of or on behalf of any undisclosed person, firm, corporation, or other business entity. Bidder has not directly or indirectly induced or solicited any other Bidder to submit a false or sham Bid. Bidder has not solicited or induced any person, firm, or a corporation to refrain from bidding. Bidder has not sought by collusion to obtain for itself any advantage over any other Bidder or against the City.

5. Bidder is bidding all schedules, alternates, if any, and will complete the Work for unit price(s) stated on the attached bid schedule based on materials actually furnished and installed and services actually provided. The Bid is summarized below on the basis of estimated quantities:

TOTAL BASE BID, IN NUMERALS: \$ \$ 110,000. ⁰⁰/₁₀₀

TOTAL BASE BID, IN WORDS: One hundred Ten thousand
DOLLARS.

6. Bidder agrees that the work for the City will be as provided above.

7. Bidder accepts the provisions of the Bidding Documents as to liquidated damages in the event of failure to complete the work on time, unless otherwise stated as provided below. Bidder agrees that such liquidated damages are not a penalty and that the amount provided is as close an estimate as possible to actual damages. Any exceptions or objections to this provision are stated in writing and attached hereto by Bidder.

8. The following documents are attached to and made a condition of this Bid:

- A. Required Bid Guaranty in the form of a Bid Bond. (Unless otherwise provided by the City.)
- B. Itemized Bid Schedule.
- C. Copy of Certificate of Residency, if bidding as Wyoming Resident.

9. Communications concerning this Bid shall be addressed to:

Address of Bidder: 2775 W. 7th Ave
Denver, CO 80204

10. The terms used in this Bid are defined in and have the meanings assigned to them in the General Conditions, except as provided in the Supplementary Conditions and Bidding Documents.

Bidder is bidding as a Non Resident (Insert Resident or Non-Resident)

IF BIDDER IS:

AN INDIVIDUAL

By: _____ (seal)
(Individual's Name)

doing business as: _____

Business Address: _____

Phone Number: _____

A PARTNERSHIP

By: _____ (seal)
(Firm's Name)

(General Partner)

Business Address: _____

Phone Number: _____

A CORPORATION OR LIMITED LIABILITY COMPANY

By: L F R Inc.
(Corporation's or Limited Liability Company's Name)

Colorado
(State of Incorporation or Organization)

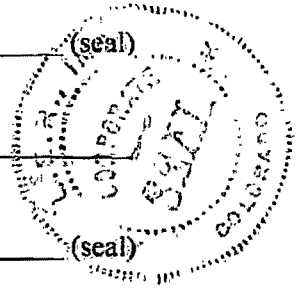

By: Neal O'Booth
(Title) Sales Manager

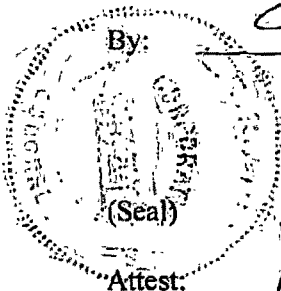

Attest: Kelley O'Booth

Business Address: 2775 W. 7th Ave
Denver CO 80204

Phone Number: 303 825-3435

A JOINT VENTURE

By: _____ (seal)
(Name)

(Address)

By: _____ (seal)
(Name)

(Address)

(Each joint venturer must sign. The manner of signing for each individual, partnership, and corporation that is a party to the joint venture should be in the manner indicated above.)

Highland Park Pickleball Court Resurfacing
Project No. 23-013

BASE BID SCHEDULE

NO.	DESCRIPTION	UNIT	QUANTITY	UNIT COST (in numeral)	Total Cost
1	R&R SURFACING/STRIPING CONVERTING TENNIS COURT TO PICKLEBALL COURTS	EA	2	27,000	54,000
2	F&I PICKLEBALL POSTS, SLEEVES, NETS, MOUNTS/FOOTINGS, AND ACCOMPANYING HARDWARE	EA	8	4,500	36,000
3	F&I PICKLEBALL 4-FT CHAINLINK FENCING, GATE, AND ACCOMPANYING HARDWARE	EA	2	10,000	20,000
TOTAL BASE BID SCHEDULE					110,000

ALTERNATE BID SCHEDULE

NO.	DESCRIPTION	UNIT	QUANTITY	UNIT COST (in numeral)	Total Cost
1	F&I PICKLEBALL 6-FT CHAINLINK FENCING, GATE, AND ACCOMPANYING HARDWARE	EA	2	12,000	24,000

ADDENDUM NO. 1

to the
BIDDING AND CONTRACT DOCUMENTS
for the

HIGHLAND PARK PICKLEBALL COURT RESURFACING
PROJECT NO. 23-013

For
THE CITY OF CASPER, WYOMING

ADDENDUM DATE: March 21, 2023

Receipt of this Addendum must be acknowledged by filling in the spaces provided below and including one (1) copy attached to the bid.

APPROVED: (CITY OF CASPER)

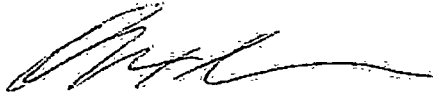

Alex Sveda, P.E.
City Engineer

ACKNOWLEDGMENT OF RECEIPT OF
ADDENDUM (BIDDER)

LER Inc
Firm

[Signature]
By: Signature

Sales Manager
Title

3-21-23
Date Received

ADDENDUM NO. 2

to the
BIDDING AND CONTRACT DOCUMENTS
for the

HIGHLAND PARK PICKLEBALL COURT RESURFACING
PROJECT NO. 23-013

For
THE CITY OF CASPER, WYOMING

ADDENDUM DATE: March 24, 2023

Receipt of this Addendum must be acknowledged by filling in the spaces provided below and including one (1) copy attached to the bid.

APPROVED: (CITY OF CASPER)

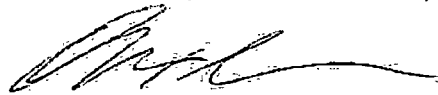

Alex Sveda, P.E.
City Engineer

ACKNOWLEDGMENT OF RECEIPT OF
ADDENDUM (BIDDER)

LER Inc
Firm

[Handwritten Signature]
By: Signature

Sales Manager
Title

3-24-23
Date Received

ADDENDUM NO. 3

to the
BIDDING AND CONTRACT DOCUMENTS
for the

HIGHLAND PARK PICKLEBALL COURT RESURFACING
PROJECT NO. 23-013

For
THE CITY OF CASPER, WYOMING

ADDENDUM DATE: April 3, 2023

Receipt of this Addendum must be acknowledged by filling in the spaces provided below and including one (1) copy attached to the bid.

APPROVED: (CITY OF CASPER)



Alex Sveda, P.E.
City Engineer

ACKNOWLEDGMENT OF RECEIPT OF
ADDENDUM (BIDDER)

LER Inc
Firm

Neil Over
By: Signature

Sales Manager
Title

4-3-23
Date Received

ADDENDUM NO. 4

to the
BIDDING AND CONTRACT DOCUMENTS
for the

HIGHLAND PARK PICKLEBALL COURT RESURFACING
PROJECT NO. 23-013

For
THE CITY OF CASPER, WYOMING

ADDENDUM DATE: April 6, 2023

Receipt of this Addendum must be acknowledged by filling in the spaces provided below and including one (1) copy attached to the bid.

APPROVED: (CITY OF CASPER)

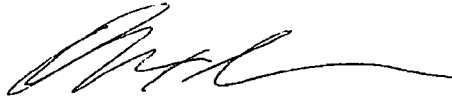

Alex Sveda, P.E.
City Engineer

ACKNOWLEDGMENT OF RECEIPT OF
ADDENDUM (BIDDER)

Firm

By: Signature

Title

Date Received

ADDENDUM NO. 4

to the
BIDDING AND CONTRACT DOCUMENTS
for the

HIGHLAND PARK PICKLEBALL COURT RESURFACING
PROJECT NO. 23-013

For
THE CITY OF CASPER, WYOMING

ADDENDUM DATE: April 6, 2023

This addendum to the project manual is hereby made a part of the Contract Documents for the above titled project, to the same extent as though it were originally contained therein.

All bidders are expected to thoroughly examine each item enumerated herein, regardless of its apparent application and shall be responsible for furnishing all labor and materials required in the division of work that the items indicate.

CONTRACT DOCUMENTS

STANDARD ADVERTISEMENT FOR BID, Page AB-2: REPLACE “Notice is hereby given, pursuant to Wyoming Statute Section 15-1-113, that the City of Casper, Wyoming, will receive sealed bids until 9:00AM on April 7, 2023.

•

WITH

“Notice is hereby given, pursuant to Wyoming Statute Section 15-1-113, that the City of Casper, Wyoming, will receive sealed bids until **3:30 PM** on **April 7, 2023**.

END OF ADDENDUM NO. Four



Wyoming Secretary of State
 Herschler Bldg East, Ste.100 & 101
 Cheyenne, WY 82002-0020
 Ph. 307-777-7311

<u>For Office Use Only</u>
WY Secretary of State FILED: Apr 26 2023 10:10AM Original ID: 2023-001259610

Profit Corporation
Articles of Incorporation

- I. **The name of the profit corporation is:**
 L.E.R., INC.

- II. **The name and physical address of the registered agent of the profit corporation is:**
 C T Corporation System
 2232 Dell Range Blvd Ste 200
 Cheyenne, WY 82009

- III. **The mailing address of the profit corporation is:**
 2775 W 7th Ave
 Denver
 Denver, CO 80204

- IV. **The principal office address of the profit corporation is:**
 2775 W 7th Ave
 2775 W 7th Ave
 Denver, CO 80204

- V. **The number, par value, and class of shares the profit corporation will have the authority to issue are:**

Number of Common Shares:	unlimited	Common Par Value.	\$12.1500
Number of Preferred Shares:	0	Preferred Par Value:	\$0.0000

- VI. **The name and address of each incorporator is as follows:**
 Greg McKenna
 2775 W 7th Ave Denver CO 80204

 FieldTurf USA Inc.
 175 N Industrial Blvd NE Calhoun GA 30701

Signature: *Kelley Pritchett* **Date:** 04/26/2023
Print Name: Kelley Pritchett
Title: Executive Administrator
Email: kbaroni@rennersports.com
Daytime Phone #: (303) 825-3435

- I am the person whose signature appears on the filing; that I am authorized to file these documents on behalf of the business entity to which they pertain; and that the information I am submitting is true and correct to the best of my knowledge.
- I am filing in accordance with the provisions of the Wyoming Business Corporation Act, (W.S. 17-16-101 through 17-16-1804) and Registered Offices and Agents Act (W.S. 17-28-101 through 17-28-111).
- I understand that the information submitted electronically by me will be used to generate Articles of Incorporation that will be filed with the Wyoming Secretary of State.
- I intend and agree that the electronic submission of the information set forth herein constitutes my signature for this filing.
- I have conducted the appropriate name searches to ensure compliance with W.S. 17-16-401.
- I affirm, under penalty of perjury, that I have received actual, express permission from each of the following incorporators to add them to this business filing: Greg McKenna, FieldTurf USA Inc.
- I consent on behalf of the business entity to accept electronic service of process at the email address provided with Article IV, Principal Office Address, under the circumstances specified in W.S. 17-28-104(e).

Notice Regarding False Filings: Filing a false document could result in criminal penalty and prosecution pursuant to W.S. 6-5-308.

W.S. 6-5-308. Penalty for filing false document.

(a) A person commits a felony punishable by imprisonment for not more than two (2) years, a fine of not more than two thousand dollars (\$2,000.00), or both, if he files with the secretary of state and willfully or knowingly:

(i) Falsifies, conceals or covers up by any trick, scheme or device a material fact;

(ii) Makes any materially false, fictitious or fraudulent statement or representation; or

(iii) Makes or uses any false writing or document knowing the same to contain any materially false, fictitious or fraudulent statement or entry.

- I acknowledge having read W.S. 6-5-308.

Filer is: An Individual An Organization

Filer Information:

By submitting this form I agree and accept this electronic filing as legal submission of my Articles of Incorporation.

Signature: *Kelley Pritchett* Date: **04/26/2023**
Print Name: **Kelley Pritchett**
Title: **Executive Administrator**
Email: **kbaroni@rennersports.com**
Daytime Phone #: **(303) 825-3435**



Wyoming Secretary of State
Herschler Bldg East, Ste.100 & 101

Cheyenne, WY 82002-0020
Ph. 307-777-7311

Consent to Appointment by Registered Agent

C T Corporation System, whose registered office is located at **2232 Dell Range Blvd Ste 200, Cheyenne, WY 82009**, voluntarily consented to serve as the registered agent for **L.E.R., INC.** and has certified they are in compliance with the requirements of W.S. 17-28-101 through W.S. 17-28-111.

I have obtained a signed and dated statement by the registered agent in which they voluntarily consent to appointment for this entity.

Signature: **Kelley Pritchett** Date: **04/26/2023**
Print Name: **Kelley Pritchett**
Title: **Executive Administrator**
Email: **kbaroni@rennersports.com**
Daytime Phone #: **(303) 825-3435**

STATE OF WYOMING
Office of the Secretary of State

I, CHUCK GRAY, Secretary of State of the State of Wyoming, do hereby certify that the filing requirements for the issuance of this certificate have been fulfilled.

CERTIFICATE OF INCORPORATION

L.E.R., INC.

I have affixed hereto the Great Seal of the State of Wyoming and duly executed this official certificate at Cheyenne, Wyoming on this **26th** day of **April, 2023** at **10:10 AM**.



Remainder intentionally left blank.



Filed Date: 04/26/2023

Secretary of State

Filed Online By:

Kelley Pritchett

on 04/26/2023

CITY OF CASPER
CHANGE ORDER

DATE OF ISSUANCE: 04/20/2023

NO. One (1)

PROJECT: Highland Park Pickleball Court Resurfacing, Project No. 23-013

OWNER: City of Casper, Wyoming

CONTRACTOR: LER, Inc., dba Renner Sports Services

ARCHITECT/ENGINEER: City of Casper

You are directed to make the following changes in the Contract Documents:

- Description: Description: Deduction of unit costs for base bid items 1, 2, and 3 and time extension as follows:
- Bid item 1 unit cost shall be reduced to \$24,000/EA, for a total revised bid item 1 cost of \$48,000.
 - Bid item 2 unit cost shall be reduced to \$3,750/EA, for a total revised bid item 2 cost of \$30,000.
 - Bid item 3 unit cost shall be reduced to \$10,000/EA, for a total revised bid item 3 cost of \$20,000.
 - The revised Substantial Completion date shall be July 1, 2024.

Attachments: None.

CHANGE IN CONTRACT PRICE	CHANGE IN CONTRACT TIME
Original Contract Price: \$110,000.00	Original Contract Time: (days or date) Substantial completion: September 22, 2023; Final completion: September 29, 2023
Previous Change Orders No. <u>0</u> to <u>0</u> :	Net change from previous Change Orders (days): <u>--0--</u> (days): <u>--0--</u>
Contract Price prior to this Change Order: \$110,000.00	Contract Time prior to this Change Order: Substantial completion: September 22, 2023; Final completion: September 29, 2023
Net Increase/Decrease change of this Change Order: \$12,000.00	Net Increase/Decrease of this Change Order: (calendar days) <u>-- 282--</u>
Contract Price with all approved Change Orders: \$98,000.00	Contract Time with all approved Change Orders:(date) Substantial completion: July 1, 2024; Final completion: July 8, 2024

ACCEPTED:

BY: 
Contractor

RECOMMENDED:

BY: 
Architect/Engineer

APPROVED:

BY: _____
Owner

CO-1

RESOLUTION NO. 23-82

A RESOLUTION AUTHORIZING AN AGREEMENT WITH LER, INC., DBA RENNER SPORTS SURFACES, FOR THE HIGHLAND PARK PICKLEBALL COURT RESURFACING, PROJECT NO. 23-013.

WHEREAS, the City of Casper desires to convert two existing tennis courts at Highland Park into standard pickleball courts; and,

WHEREAS, LER, Inc., dba Renner Sports Surfaces, is able and willing to provide those services, specified as the Highland Park Pickleball Court Resurfacing, Project No. 23-013; and,

WHEREAS, it would be in the best interest of the City to expedite changes in the project by allowing the City Manager to sign change orders effecting time extensions of no more than Thirty (30) days, dollar amount changes no greater than One Thousand Dollars (\$1,000) and other project administration related change orders that do not substantially alter the scope of the project.

NOW, THEREFORE, BE IT RESOLVED BY THE GOVERNING BODY OF THE CITY OF CASPER, WYOMING: That the Mayor is hereby authorized and directed to execute, and the City Clerk to attest, an Agreement with LER, Inc., dba Renner Sports Surfaces, for those services, in the amount of Ninety-Eight Thousand and 00/100 Dollars (\$98,000.00).

BE IT FURTHER RESOLVED: That the City Manager is hereby authorized to make verified partial payments and contract extensions throughout the project, retaining those amounts prescribed by the Agreement, equal to a total amount not to exceed Ninety-Eight Thousand and 00/100 Dollars (\$98,000.00) and Five Thousand and 00/100 Dollars (\$5,000.00) for a construction contingency account, for a total project amount of One Hundred Three Thousand and 00/100 Dollars (\$103,000.00)

BE IT FURTHER RESOLVED: That the City Manager is hereby authorized to sign change orders effecting time extensions of no more than thirty (30) days, changes in the dollar amount of the above described Agreement not greater than the sum of Five Thousand and 00/100 Dollars (\$5,000.00), and other project administration related change orders that do not substantially alter the scope of the project.

PASSED, APPROVED, AND ADOPTED this ____ day of _____, 2023.

APPROVED AS TO FORM:

Walter Trumbull

ATTEST:

CITY OF CASPER, WYOMING
A Municipal Corporation

Fleur Tremel
City Clerk

Bruce Knell
Mayor

THE REMAINDER OF THIS PAGE IS INTENTIONALLY LEFT BLANK

April 19, 2023

MEMO TO: J. Carter Napier, City Manager *JCN*

FROM: Andrew Beamer, P.E., Public Services Director *AB*
 Alex Sveda, P.E., City Engineer *AS*
 Zulima Lopez, Parks, Recreation & Public Facilities Director
 Scott R. Baxter, P.E., Associate Engineer

SUBJECT: Authorizing an Agreement with Caspar Building Systems, Inc., in the Amount of \$5,202,000.00, for the City Hall Project S.A.F.E. Building Remodel, Project No. 20-004.

Meeting Type & Date
 Regular Council Meeting
 May 2, 2023

Action Type
 Resolution

Recommendation
 That Council, by resolution, authorize an Agreement with Caspar Building Systems, Inc., for construction of the City Hall Project S.A.F.E. Building Remodel, Project No. 20-004, for the base bid amount of \$4,636,000.00, and two alternate bids in the amount of \$566,000.00. Furthermore, it is recommended that Council authorize a construction contingency account in the amount of \$258,000.00, for a total project amount of \$5,460,000.00.

Summary
 On April 11, 2023, bids were received from four (4) contractors for construction of the City Hall Project S.A.F.E. Building Remodel Project. The bids for the work were as follows:

<u>CONTRACTOR</u>	<u>LOCATION</u>	<u>BASE BID</u>
Caspar Building Systems	Casper, Wyoming	\$4,636,000.00
Haass Construction	Casper, Wyoming	\$4,754,851.00
Sampson Construction	Cheyenne, Wyoming	\$5,278,000.00
GH Phipps of Wyoming	Laramie, Wyoming	\$5,619,000.00

The estimate for the base bid portion of the project was \$4,414,500, prepared by the City's architect, State Line No. 7 Architects.

There were also two (2) alternates included in the bid package. Alternate #1 includes remodeling of Council Chambers, and Alternate #2 includes all exterior site improvements. The ADD ALTERNATE bid amounts were as follows:

<u>CONTRACTOR</u>	<u>ALTERNATE #1</u>	<u>ALTERNATE #2</u>
Caspar Building Systems	\$181,000.00	\$385,000.00
Haass Construction	\$201,155.00	\$550,429.00
Sampson Construction	\$204,000.00	\$560,000.00
GH Phipps Wyoming	\$171,250.00	\$338,700.00

Casper’s City Hall was built in 1978 to serve as the primary facility for citizens to communicate with City officials and conduct City business. The building remains the cornerstone of City business and needs significant improvements. A holistic approach has been taken to determine improvements needed for City Hall’s safety/security, aesthetics, functionality, and efficiency (S.A.F.E.)

Primary improvements for the City Hall Project S.A.F.E. Building Remodel are as follows:

- Correction of exterior and interior vulnerabilities for safety of employees and visitors.
- Improvement of fire suppression system deficiencies that violate current fire code.
- Improvement of customer service and operational efficiency.
- Compliance with current ADA regulations in public bathrooms and other areas throughout the building.
- Improvement of the building exterior to be more inviting to visitors, direct visitors to a primary entrance that engages customers with employees, and provide useful space for employees to gather or take breaks.
- Improvement of general finish items such flooring, lighting, and paint.
- Improvement of the HVAC system throughout the facility which is failing due to age and construction materials.
- Replacement of air handlers to match the new HVAC system and building improvements.
- Improvement of Atrium lighting and setup for important public meetings, communication and interaction.

State Line No. 7 Architects has reviewed the bids and found them to be sound and complete. State Line No. 7 has also reviewed the qualifications of Caspar Building Systems and its subcontractors and found them to be well qualified for the project. State Line No. 7 recommends awarding a contract to Caspar Building Systems.

Financial Considerations

Funding for the project will be from Capital Reserves in the amount of \$2,567,306.00, One Cent #17 in the amount of \$1,002,000.00, and excess One Cent #16 in the amount of \$1,890,694.00.

Oversight/Project Responsibility

Scott R. Baxter, P.E., Associate Engineer, Public Services Department.

Attachments

- Resolution
- Agreement
- Bid Form
- Consultant’s Award Recommendation

STANDARD FORM OF
AGREEMENT BETWEEN OWNER AND CONTRACTOR

THIS AGREEMENT is made between the City of Casper, 200 N. David Street, Casper, WY 82601, hereinafter referred to as the "Owner," and Caspar Building Systems, Inc., 1975 Old Salt Creek Highway, Casper, WY 82601, hereinafter referred to as the "Contractor."

WHEREAS, the City of Casper desires to remodel the existing City Hall building at 200 N. David Street, and,

WHEREAS, Caspar Building Systems, Inc., is able and willing to provide those services specified as the City Hall Project S.A.F.E. Building Remodel, Project No. 20-004.

NOW, THEREFORE, it is hereby agreed as follows:

ARTICLE 1. WORK.

Contractor shall perform all the work required by the Contract Documents for the Casper City Hall Project S.A.F.E. Building Remodel, Project No. 20-004.

ARTICLE 2. ENGINEER.

The Project has been designed by the City of Casper's consultant, Stateline No. 7 Architects, 444 South Center Street, Casper, Wyoming, who is hereinafter referred to as the "Architect" or "Engineer" and who is to act as Owner's representative, assume all duties and responsibilities and have the rights and authority assigned to Architect and/or Engineer in the Contract documents in connection with completion of the Work in accordance with the Contract documents.

ARTICLE 3. CONTRACT TIME.

- 3.1 The Work will be substantially completed by May 30, 2024, and completed and ready for final payment in accordance with Article 14 of the General Conditions by July 15, 2024.
- 3.2 Liquidated Damages. Owner and Contractor recognize that time is of the essence of this Agreement and that Owner will suffer financial loss if the Work is not substantially completed by the time specified in Paragraph 3.1 above, plus any extension thereof allowed in accordance with Article 12 of the General Conditions. They also recognize the delays, expense, and difficulties involved in proving in a legal or arbitration proceeding the actual loss suffered by Owner if the Work is not substantially completed on time. Accordingly, instead of requiring any such proof, Owner and Contractor agree that as liquidated damages for delay (but not as a penalty) Contractor shall pay Owner One Thousand Dollars (\$1,000.00) for each day that expires after the time specified in Paragraph 3.1 for substantial completion. After Substantial Completion, if the Contractor shall

Caspar Building Systems, Inc.
City Hall Project S.A.F.E. Building Remodel, Project No. 20-004

neglect, refuse, or fail to complete the remaining work within the time specified in paragraph 3.1 for completion and readiness for final payment or any proper extension thereof granted by Owner, Contractor shall pay Owner Five Hundred Dollars (\$500.00) for each day that expires after the time specified in paragraph 3.1 for completion and readiness for final payment. It is further agreed that such liquidated damages are not a penalty, but represent the parties' best estimate of actual damages.

ARTICLE 4. CONTRACT PRICE.

In Consideration of the performance of the work in accordance with the Contract documents for this Lump Sum Contract, Owner shall pay Contractor in current funds a total contract price of Five Million Two Hundred Two Thousand and 00/100 Dollars (\$ 5,202,000.00) subject to additions and deductions by Change Order approved by the Owner. The contract fee shall be based on materials actually furnished and installed and services actually provided based on the price contained in the Bid Form, included as Exhibit "A" (pages BF-1 through BF-5, Bid Form) and by this reference made a part of this Agreement. The contract price includes the Base Bid, Alternate No. 1, and Alternate No. 2.

ARTICLE 5. PAYMENT PROCEDURES.

Contractor shall submit Applications for Payment in accordance with Article 14 of the General Conditions. Applications for Payment will be processed through the Engineer as provided in the General Conditions.

5.1 Progress Payments. Contractor's Applications for Payment, as recommended by Architect and/or Engineer, shall be submitted to accountspayable@casperwy.gov and City Engineering Staff on or before the 25th day of each month during construction, and Owner shall mail progress payments in the following month one day after the second monthly meeting of the Casper City Council. Progress payments shall be structured as provided below. All progress payments will be on the basis of the progress of the Work measured by the Schedule of Values provided for in Paragraph 14.01 of the General Conditions, subject to the cutoff and submittal dates provided in the Measurement and Payment Procedures.

5.1.1 Progress payments will be made in an amount equal to ninety five percent (95%) of the Work completed, and ninety five percent (95%) of Invoice Cost of materials and equipment not incorporated in the Work but delivered and suitably stored, less in each case the aggregate of payments previously made.

5.1.2 Owner shall withhold five percent (5%) of the work completed as retainage, said retainage to be paid in accordance with the provisions of Paragraph 5.2, Final Payment.

5.1.3 Should amounts owed by the Contractor to the City for any goods, services, licenses, permits or any other item or purpose remain unpaid beyond the City's general credit policy,

those amounts may be deducted from the payment being made by the City to the Contractor pursuant to this agreement.

- 5.2 OWNER may withhold progress payments if CONTRACTOR fails to submit an updated progress schedule with the application for payment as detailed in Section 01310 Progress Schedules.
- 5.3 Final Payment. Upon final completion and acceptance of the Work in accordance with Article 14 of the General Conditions, Architect and/or Engineer shall recommend payment and present Contractor's Final Application for Payment to the City. Pursuant to Wyoming State Statutes, final payment cannot be made until forty-one (41) days after publication of the first Notice of Completion.

ARTICLE 6. WITHHELD FUNDS.

Pursuant to Wyoming Statutes Section 16-6-701 et seq., withheld percentages for Contracts exceeding fifty thousand dollars (\$50,000.00) will be retained in an account in the name of the Contractor (except when specifically waived in writing by Contractor) which has been assigned to the Owner until the Contract is completely, satisfactorily, and finally accepted by the Owner. Unless a depository is designated by the Contractor in a written attachment hereto, the Contractor's signature hereon shall act as authority for the Owner to designate a retainage depository on behalf of the Contractor, for the purposes specified in Wyoming Statutes Section 16-6-704. The Contractor's signature hereon shall act as an assignment of the depository account to the Owner, as provided by Wyoming Statutes Section 16-6-701 et seq., whether the depository is designated by the Contractor or by the Owner.

ARTICLE 7. CONTRACTOR'S REPRESENTATIONS.

In order to induce Owner to enter into this Agreement, Contractor makes the following representations:

- 7.1 Contractor has familiarized himself with the nature and extent of the Contract documents, Work, locality, and with all local conditions and federal, state, and local Laws and Regulations that in any manner may affect cost, progress, or performance of the Work.
- 7.2 Contractor has studied carefully all reports of investigations and test of subsurface and latent physical conditions at the site or otherwise affecting cost, progress, or performance of the Work which were relied upon by Architect and/or Engineer in the preparation of the Drawings and Specifications and which have been identified in the Supplementary Conditions.
- 7.3 Contractor has made or caused to be made examinations, investigations, and test and studies as he deems necessary for the performance of the Work at the Contract price, within the Contract Time, and in accordance with the other terms and conditions of the Contract documents; and no additional examinations, investigations, tests, reports, or similar data are or will be required by Contractor for such purposes.

- 7.4 Contractor has correlated the results of all such observations, examinations, investigations, tests, reports, and data with the terms and conditions of the Contract documents.
- 7.5 Contractor has given Architect and/or Engineer written notice of all conflicts, errors, or discrepancies that he has discovered in the Contract documents and the written resolution thereof by Engineer is acceptable to Contractor.

ARTICLE 8. CONTRACT DOCUMENTS.

The Contract documents which comprise the entire agreement between Owner and Contractor are attached to this Agreement, made a part hereof and consist of the following:

- 8.1 This Agreement (Pages SFA-1 to SFA-6, inclusive).
- 8.2 Standard Joint Account Agreement or Letter of Forfeiture waiving same.
- 8.3 Exhibit "A" – Standard Bid Form (Pages BF-1 to BF-5, inclusive).
- 8.4 Addenda No. 1, 2, 3.
- 8.5 Standard Performance and Labor and Material Payment Bonds.
- 8.6 Certificates of Insurance, of Workers' Compensation Coverage, and of Unemployment Insurance Coverage.
- 8.7 Standard General Conditions (Pages 00700-1 to 00700-42, inclusive).
- 8.8 Standard Supplementary Conditions (Pages SSC-1 to SSC-16, inclusive).
- 8.9 Technical Specifications, consisting of one hundred thirty-nine (139) sections.
- 8.10 Special Provisions (none).
- 8.11 Notice of Award.
- 8.12 Notice to Proceed.
- 8.13 Minutes of the Pre-Bid Conference, if any.
- 8.14 Shop Drawings and other Submittals furnished by Contractor during performance of the Work and accepted by the Owner.

Caspar Building Systems, Inc.
City Hall Project S.A.F.E. Building Remodel, Project No. 20-004

SFA-4

- 8.15 Any modifications, amendments, and supplements, including Change Orders, issued pursuant to Paragraphs 3.4 and 3.5 of the General Conditions, on or after the effective date of this Agreement.
- 8.16 Certificate of Substantial Completion.
- 8.17 Standard Letter of Completion
- 8.18 Drawings: Casper City Hall Project S.A.F.E. Building Remodel.

ARTICLE 9. GOVERNMENTAL CLAIMS ACT

The Owner does not waive any right or rights it may have pursuant to the Wyoming Governmental Claims Act, Wyoming Statutes Section 1-39-101 et seq. The Owner specifically reserves the right to assert any and all immunities, rights, and defenses it may have pursuant to the Wyoming Governmental Claims Act.

ARTICLE 10. MISCELLANEOUS PROVISIONS.

Terms used in this Agreement, which are defined in the General Conditions, shall have the meanings designated in those conditions.

(this space intentionally left blank)

IN WITNESS WHEREOF, the parties hereto have caused this Agreement to be executed in one (1) original copy on the day and year first above written.

APPROVED AS TO FORM:

(Casper City Hall Project S.A.F.E. Building Remodel, Project 20-004)

Walter Tremel

DATED this _____ day of _____, 2023.

ATTEST:

CONTRACTOR:

Caspar Building Systems, Inc.
1975 Old Salt Creek Highway
Casper, Wyoming 82601

By: _____

By: _____

Title: _____

Title: _____

ATTEST:

OWNER:

CITY OF CASPER, WYOMING
A Municipal Corporation

By: _____

By: _____

Fleur Tremel

Bruce Knell

Title: City Clerk

Title: Mayor

EXHIBIT "A"
STANDARD
BID FORM

PROJECT IDENTIFICATION: City of Casper
 Casper City Hall
 Project S.A.F.E.
 Building Remodel
 Project No. 20-004

THIS BID SUBMITTED TO: City of Casper
 200 North David Street
 Casper, Wyoming 82601

1. The undersigned Bidder proposes and agrees, if this Bid is accepted, to enter into an Agreement with the City in the form included in the Bidding Documents and to complete all Work as specified or indicated in the Bidding Documents for the Contract Price by **May 30, 2024**, and completed and ready for final payment not later than **July 15, 2024**, in accordance with the Bidding Documents.

2. Bidder accepts all of the terms and conditions of the Advertisement for Bids and Instructions to Bidders, including without limitation those dealing with the disposition of Bid Guaranty. This Bid will remain effective for thirty (30) days after the day of Bid opening. Bidder will sign the Agreement and submit the Bonds and other documents required by the Bidding Documents within thirty (30) days after the date of the City's Notice of Award.

3. Notice that preferences will be granted pursuant to Wyoming Statutes Section 17-7-101, et seq., is hereby acknowledged.

4. In submitting this Bid, Bidder represents, as more fully set forth in the Bidding Documents, that:
 - A. Bidder has examined copies of all the Bidding Documents and of the following addenda (receipt of all which is hereby acknowledged):

Addendum No. <u> 1 </u>	Dated <u> 3-27-23 </u>
Addendum No. <u> 2 </u>	Dated <u> 4-3-23 </u>
Addendum No. <u> 3 </u>	Dated <u> 4-7-23 </u>
Addendum No. _____	Dated _____
Addendum No. _____	Dated _____

- B. Bidder has examined the site and locality where the work is to be performed, the federal, state, and local Laws and Regulations, and the conditions affecting cost, progress, or performance of the work and has made such independent investigations as Bidder deems necessary;
- C. This Bid is genuine and not made in the interest of or on behalf of any undisclosed person, firm, corporation, or other business entity. Bidder has not directly or indirectly induced or solicited any other Bidder to submit a false or sham Bid. Bidder has not solicited or induced any person, firm, or a corporation to refrain from bidding. Bidder has not sought by collusion to obtain for itself any advantage over any other Bidder or against the City.
5. Bidder is bidding all schedules, alternates, if any, and will complete the Work for unit price(s) stated on the attached bid schedule based on materials actually furnished and installed and services actually provided. The Bid is summarized below on the basis of estimated quantities:

TOTAL BASE BID, IN NUMERALS: \$ 4,636,000⁰⁰
 TOTAL BASE BID, IN WORDS: FOUR MILLION SIX HUNDRED THIRTY SIX THOUSAND ⁰⁰/₁₀₀ DOLLARS.

TOTAL ADD ALTERNATE #1: COUNCIL CHAMBER REMODEL
 IN NUMERALS: \$ 181,000⁰⁰
 TOTAL ADD ALTERNATE #1: COUNCIL CHAMBER REMODEL
 IN WORDS: ONE HUNDRED EIGHTY ONE THOUSAND AND ⁰⁰/₁₀₀ DOLLARS.

TOTAL ADD ALTERNATE #2: EXTERIOR IMPROVEMENTS
 IN NUMERALS: \$ 385,000⁰⁰
 TOTAL ADD ALTERNATE #2: EXTERIOR IMPROVEMENTS IN WORDS:
THREE HUNDRED EIGHTY FIVE THOUSAND ⁰⁰/₁₀₀ DOLLARS.

6. Bidder agrees that the work for the City will be as provided above.
7. Bidder accepts the provisions of the Bidding Documents as to liquidated damages in the event of failure to complete the work on time, unless otherwise stated as provided below. Bidder agrees that such liquidated damages are not a penalty and that the amount provided is as close an estimate as possible to actual damages. Any exceptions or objections to this provision are stated in writing and attached hereto by Bidder.
8. The following documents are attached to and made a condition of this Bid:
 - A. Required Bid Guaranty in the form of a Bid Bond. (Unless otherwise provided by the City.)
 - B. Itemized Bid Schedule.
 - C. Copy of Certificate of Residency, if bidding as a resident.
9. Communications concerning this Bid shall be addressed to:

Address of Bidder: CASPAR BUILDING SYSTEMS, INC.
1975 OLD SALT CREEK HWY
CASPER, WY 82601

10. The terms used in this Bid are defined in and have the meanings assigned to them in the General Conditions, except as provided in the Supplementary Conditions and Bidding Documents.

Submitted on 4-11, 2023.

Bidder is bidding as a RESIDENT (Insert Resident or Non-Resident)

IF BIDDER IS:

AN INDIVIDUAL

By: _____ (seal)
 (Individual's Name)

doing business as: _____

Business Address: _____

Phone Number: _____

A PARTNERSHIP

By: _____ (seal)
(Firm's Name)

(General Partner)

Business Address: _____

Phone Number: _____

A CORPORATION OR LIMITED LIABILITY COMPANY

By: CASPAR BUILDING SYSTEMS, INC. (seal)
(Corporation's or Limited Liability Company's Name)

WYOMING
(State of Incorporation or Organization)

By:  WES HAYDEN, PRESIDENT (seal)

(Seal)  (Title)

Attest: _____

Business Address: 1975 OLD SALT CREEK HWY
CASPER, WY 82601

Phone Number: 307-235-5690

A JOINT VENTURE

By: _____ (seal)
(Name)

(Address)

By: _____ (seal)
(Name)

(Address)

(Each joint venturer must sign. The manner of signing for each individual, partnership, and corporation that is a party to the joint venture should be in the manner indicated above.)

April 17, 2023

Mr. Scott Baxter, P.E.
Engineering Division
City of Casper
200 North David Street
Casper, Wyoming 82601



Re: Post-Bid Recommendation for project #20-004 Casper City Hall Project S.A.F.E. Building Remodel

Dear Scott:

The Casper City Hall Project S.A.F.E. building remodel project bid on April 11th, 2023. Four general contractor bids were received, an amount indicating a healthy and competitive bid climate.

The apparent low bidder was Caspar Building Systems of Casper, Wyoming, who bid as a resident Wyoming bidder. The low base bid amount was \$118,851.00 lower than the next low bidder (less than 1% difference), and in my follow up with Caspar Building Systems the day after the bid, they confirmed that they were comfortable with their bid number and no mistakes that would warrant a withdrawal of their bid. Further investigation of their subcontractor list produced no concerns for the design team.

I have known and worked with Caspar Building Systems on several projects over the years and their work has been acceptable. This company is very well known in the Casper area and has completed other projects for the City of Casper as well, and thus I had no need to further check their references.

The low base bid amount was \$ 4,636,000.00, which is slightly higher than the project estimate of \$ 4,414,509.00 (by less than 1%) and thus acceptable within the current still-volatile bid climate caused by the past years' pandemic. And the low bidders' alternate price (alternate #1 and #2 combined) was \$566,000.00, which is slightly lower than the project estimate of \$ 545,050.00 (also by less than 1%). This past year's efforts to redesign and rebid this project were focused on "value engineering" to trim unnecessary items from the project and to make things as efficient as possible; this was confirmed by both this low bid as well as the low bidder, Caspar Building Systems, who stated that they did not see any further significant "value engineering" items for consideration. However, there are additional project costs unaccounted for such as: a modest project contingency which is necessary – especially on a remodel project – for unforeseen conditions, costs of pending plan review comments which were just recently receive by the now-departed City Building Official which could not be addressed via addendum during the bid due to timing, and of course costs to cover the budget shortfall – all totaling approximately \$ 600,000.00 of additional funding necessary for the base bid project to become viable.

I am pleased to recommend that you award the Casper City Hall Project S.A.F.E. project to the low bid contractor, Caspar Building Systems, and recommend entering into a contract to begin construction based on this favorable bid, acceptable contractor/subcontractors, and the ability to still meet the essential requirements of Project S.A.F.E.

Respectfully,

A handwritten signature in black ink, appearing to read "Lyle Murtha".

Lyle Murtha, AIA
President
Stateline No. 7 Architects



RESOLUTION NO. 23-83

A RESOLUTION AUTHORIZING AN AGREEMENT WITH CASPAR BUILDING SYSTEMS, INC., FOR THE CITY HALL PROJECT S.A.F.E. BUILDING REMODEL, PROJECT NO. 20-004.

WHEREAS, the City of Casper desires to remodel the existing City Hall at 200 N. David Street; and,

WHEREAS, Caspar Building Systems, Inc., is able and willing to provide those services specified as the City Hall Project S.A.F.E. Building Remodel, Project 20-004; and,

WHEREAS, it would be in the best interest of the City to expedite changes by allowing the City Manager to sign change orders affecting time extensions of no more than thirty (30) days, dollar amount changes no greater than Thirty-Five Thousand Dollars (\$35,000.00), and other project administration related change orders that do not substantially alter the scope of the project.

NOW, THEREFORE, BE IT RESOLVED BY THE GOVERNING BODY OF THE CITY OF CASPER, WYOMING: That the Mayor is hereby authorized and directed to execute, and the City Clerk to attest, an agreement with Caspar Building Systems, Inc., for those services, in the amount of Five Million Two Hundred Two Thousand and 00/100 Dollars (\$5,202,000.00).

BE IT FURTHER RESOLVED: That the City Manager is hereby authorized to sign change orders effecting time extensions of no more than thirty (30) days, changes in the dollar amount of the above described Agreement not greater than the sum of Thirty-Five Thousand Dollars (\$35,000.00), and other project administration related change orders that do not substantially alter the scope of the project.

BE IT FURTHER RESOLVED: That the City Manager is hereby authorized to make verified partial payments throughout the project, retaining those amounts prescribed by the Agreement, equal to a total amount not to exceed Five Million Two Hundred Two Thousand and 00/100 Dollars (\$5,202,000.00), and Two Hundred Fifty-Eight Thousand and 00/100 Dollars (\$258,000.00) for a construction contingency account, for a total price of Five Million Four Hundred Sixty Thousand and 00/100 Dollars (\$5,460,000.00).

PASSED, APPROVED, AND ADOPTED this ____ day of _____, 2023.

APPROVED AS TO FORM:
(City Hall Project S.A.F.E. Building Remodel, Project No. 20-004)



ATTEST:

CITY OF CASPER, WYOMING
A Municipal Corporation

Fleur Tremel
City Clerk

Bruce Knell
Mayor

April 10, 2023

MEMO TO: J. Carter Napier, City Manager 

FROM: Andrew Beamer, P.E., Public Services Director 
Alex Sveda, P.E., City Engineer AS
Scott R. Baxter, P.E., Associate Engineer

SUBJECT: Authorizing Amendment #1 to the Professional Services Contract with WLC Engineering & Surveying, for an additional amount of \$22,123 and a time extension of Twenty-Nine (29) calendar days for the Industrial Avenue Drainage & Surfacing Improvements (Elm to David), Project No. 21-055.

Meeting Type & Date

Regular Council Meeting
May 2, 2023

Action Type

Resolution

Recommendation

That Council, by Resolution, authorize Amendment #1 to the Professional Services Contract with WLC Engineering & Surveying (WLC), for an additional amount of \$22,123 and a time extension of Twenty-Nine (29) calendar days for the Industrial Avenue Drainage & Surfacing Improvements (Elm to David), Project No. 21-055.

Summary

WLC has been under contract with the City of Casper since November 5, 2021 for the Industrial Avenue Drainage & Surfacing Improvements (Elm to David) Project. The purpose of the project is to reconstruct the street section from Elm Street to David Street with the addition of curbs, sidewalks and ADA accessible ramps, upgrade the storm sewer with new catch basins and upsized mains, and replace one section of failing sanitary sewer main. The original deadline for substantial completion was September 30, 2022.

The contractor on the project, Treto Construction, encountered delays due to site conditions, for which a time extension of forty-one (41) days has been granted. However, Treto Construction also ran late on their construction schedule and did not reach substantial completion until November 21, 2022, and reached final completion on December 9, 2022, which resulted in \$15,000 of liquidated damages assessed against Treto Construction.

WLC continued to inspect, report and manage construction of the project for approximately three (3) months beyond what was expected in the construction deadlines and proposed schedule. The extra scope impacting this amendment included on-site observation/reporting, meetings, and extensive change order drafts and revisions. The total additional cost associated with WLC's extra time to complete the project is \$22,123. The additional time extension for WLC's contract is only associated with future resolution of warranty items that may arise.

The City of Casper Engineering staff has reviewed WLC's amendment proposal and recommends approval.

Financial Considerations

Funding will from unused Optional 1%#16 Sales Tax funds remaining in the project.

Oversight/Project Responsibility

Scott R. Baxter, P.E., Associate Engineer, Public Services Department

Attachments

Resolution

Consultant Proposal

**AMENDMENT NO. 1 TO THE CONTRACT
FOR PROFESSIONAL SERVICES (“AMENDMENT”)**

This Amendment to the Contract for Professional Services (“Amendment”) is entered into on this 2nd day of May, 2023, by and between the following parties:

1. The City of Casper of Casper, Wyoming (“City”), a Wyoming municipal corporation, 200 North David Street, Casper, Wyoming 82601.
2. WLC Engineering & Surveying, 200 Pronghorn, Casper, Wyoming 82601 (“Consultant”).

Throughout this document, the City and the Consultant may be collectively referred to as the “parties.”

RECITALS

A. On November 5th, 2021, the City and Consultant entered into a *Contract for Professional Services* (“Contract”) for construction administration services for the Industrial Avenue Drainage & Surfacing Improvements (Elm to David), Project No. 21-055.

B. The project requires additional time for construction administration.

NOW, THEREFORE, in consideration of the mutual promises and covenants contained herein, the parties hereto agree by and between them to amend the Contract as follows:

1. INCORPORATION OF RECITALS

The recitals set forth above are hereby incorporated herein at this point as if fully set forth as part of this Amendment.

2. AMENDMENT TO PART I, SECTIONS 1., 2., AND 3.

SECTION 1 includes “SCOPE OF SERVICES” and is expanded with the following: See the attached Exhibit “A”, made part of this amendment.

SECTION 2 includes “TIME OF PERFORMANCE” and the date “30th day of November, 2023” is deleted in its entirety and replaced with the date “29th day of December 2023.”

SECTION 3 includes “COMPENSATION” and the amount of Twenty-Two Thousand One Hundred Twenty-Three and 00/100 Dollars (\$22,123.00) is hereby added,

bringing the new lump sum total to Ninety Thousand Five Hundred Twenty-Three and 00/100 Dollars (\$90,523.00).

3. RATIFICATION

The terms and conditions of the Contract, as modified herein, are hereby ratified by the parties and shall remain in full force and effect.

IN WITNESS WHEREOF, the undersigned duly authorized representatives of the Parties have executed this Amendment as of the day and year above.

APPROVED AS TO FORM

Walter Tremel

ATTEST

CITY OF CASPER, WYOMING
A Municipal Corporation

Fleur Tremel
City Clerk

Bruce Knell
Mayor

WITNESS

CONSULTANT
WLC Engineering & Surveying

By: _____

By: _____

Printed Name: _____

Printed Name: _____

Title: _____

Title: _____

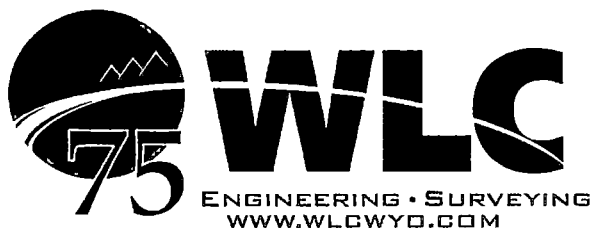

CASPER
200 PRONGHORN
CASPER, WY 82601
P: 307-266-2524

March 13, 2023

Mr. Scott Baxter, PE
City of Casper, Engineering Department
Submitted via email

RE: Industrial Avenue Drainage and Surfacing Improvements, Elm to David, Amendment Request

Mr. Baxter:

WLC submitted an Amendment Request on October 26, 2022 to increase our fees in the amount of \$18,400.00. See attached. This request was based upon the project being complete on November 12, 2022. Upon submittal of the Amendment Request, The City of Casper instructed us to spend minimal time onsite to reduce our fees as much as possible. We were only on site once in the morning and once in the afternoon to document progress.

The Contractor was complete with the work on December 9, 2022. Since then, there has been numerous meetings with the Contractor and the City, several requests from the Contractor to respond to, and several revisions to the Final Change Order to reconcile all quantities and additional requests from the Contractor. We believe that all of the work is complete, and all Contractor requests have been addressed. The Final Change Order is complete and has been sent to the Contractor for signature.

To date, we have expended a total of \$90,525.00. This total is \$22,123.00 beyond our original Agreement amount of \$68,400. We are requesting that the City of Casper consider a request for an additional \$22,123.00.

Please contact me to if you have any questions concerning this request.

Respectfully,
WLC Engineering and Surveying

A handwritten signature in black ink that reads 'Jason L. Meyers'.

Jason L. Meyers, PE
Project Manager

Encl.

CASPER

RAWLINS

DEDICATED TO CLIENTS. DEFINED BY EXCELLENCE.



CASPER
 200 PRONGHORN
 CASPER, WY 82601
 P: 307-266-2524

October 26, 2022

Mr. Scott Baxter, PE
 City of Casper, Engineering Department
 Submitted via email

RE: Industrial Avenue Drainage and Surfacing Improvements, Elm to David, Amendment Request

Mr. Baxter:

Per the Agreement between the City of Casper and WLC Engineering and Surveying, dated November 5, 2021, our Fee Proposal was based upon the construction lasting 60 working days. As of today, we have documented 70 working days and have exhausted our budget for construction services.

The Contractor’s latest schedule indicates they will be complete by November 12, 2022. With the current progress, we anticipate that Substantial Completion may be met by this date. We anticipate the remainder of miscellaneous items will take at least another week to complete. These miscellaneous items include patching behind curbs, signs, and small concrete replacements. We anticipate 22 working days, from today, for completion of the construction.

Below is a list of tasks that WLC has left to complete.

- Construction Observation (average 4 hours per contractor working day).
- Concrete field testing.
- Concrete laboratory compressive testing.
- Subgrade density testing.
- Progress Meetings.
- Project Manager site visits, as necessary.
- Complete CO #2.
- Substantial Completion walkthrough and punch list.
- Final Change Order.
- Compile and prepare record drawings.

We are requesting an amendment to our Agreement in the amount of \$18,400.00. Our Agreement amount is for \$68,400.00. This amendment amount would bring our Agreement amount to \$86,800.00.

Please contact me to if you have any questions concerning this request.

Respectfully,
 WLC Engineering and Surveying

Jason L. Meyers, PE
 Project Manager

RESOLUTION NO. 23-84

A RESOLUTION AUTHORIZING AMENDMENT NO. 1 TO THE CONTRACT FOR PROFESSIONAL SERVICES WITH WLC ENGINEERING & SURVEYING, FOR CONSTRUCTION ADMINISTRATION SERVICES FOR THE INDUSTRIAL AVENUE DRAINAGE & SURFACING IMPROVEMENTS (ELM TO DAVID), PROJECT NO. 21-055.

WHEREAS, WLC Engineering & Surveying, under a Contract for Professional Services dated November 5, 2021, is providing construction administration services for the Industrial Avenue Drainage & Surfacing Improvements (Elm to David) Project; and,

WHEREAS, additional services outside the original scope of work are required for construction administration; and,

WHEREAS, the City of Casper desires to extend the scope of work with WLC Engineering & Surveying, to provide these additional services; and,

WHEREAS, WLC Engineering & Surveying is able and willing to provide those services as specified in Amendment No. 1.

NOW, THEREFORE, BE IT RESOLVED BY THE GOVERNING BODY OF THE CITY OF CASPER, WYOMING: That the Mayor is hereby authorized and directed to execute, and the City Clerk to attest, Amendment No. 1 to the Contract for Professional Services with WLC Engineering & Surveying for additional construction administration services in the amount of Twenty-Two Thousand One Hundred Twenty-Three and 00/100 Dollars (\$22,123.00).

BE IT FURTHER RESOLVED: That the City Manager is hereby authorized to make verified partial payments and contract extensions throughout the project, retaining those amounts prescribed by the Agreement, equal to an additional amount not to exceed Twenty-Two Thousand One Hundred Twenty-Three and 00/100 Dollars (\$22,123.00), for a total contract amount of Ninety Thousand Five Hundred Twenty-Three and 00/100 Dollars (\$90,523.00).

PASSED, APPROVED, AND ADOPTED this ____ day of _____, 2023.

APPROVED AS TO FORM:



ATTEST:

CITY OF CASPER, WYOMING
A Municipal Corporation

Fleur Tremel
City Clerk

Bruce Knell
Mayor

April 14, 2023

MEMO TO: J. Carter Napier, City Manager 

FROM: Andrew Beamer, P.E., Public Services Director 
Bruce Martin, Public Utilities Manager

SUBJECT: Authorizing an Agreement between the Natrona County Conservation District and the City of Casper

Meeting Type & Date

Regular Council Meeting Scheduled for May 2, 2023.

Action Type

Resolution

Recommendation

That Council, by resolution, authorize an agreement between the City of Casper and the Natrona County Conservation District (District) in the amount of \$40,000.

Summary

The District has been partially funded by the City of Casper from 1992 to 2006, in the amount of \$12,500 per year because of Casper's vested interest in water savings projects for the Casper-Alcova Irrigation District. Additional monies have been funded by Natrona County over the years. The District has also received grant funding from the Department of Environmental Quality (DEQ) and the Environmental Protection Agency (EPA) Clean Water 319 program, Wyoming Water Development Commission (WWDC), and other grant programs.

In February 2006, the District approached the Casper Public Utilities Advisory Board and requested an increase in Casper's participation to \$25,000 per year due to the increasing number and costs of programs undertaken by the District. This was approved by the CPU Advisory Board and the amount of \$25,000 has been included in the Public Utilities budgets. This amount was matched by Natrona County.

The District approached the Casper Public Utilities Advisory Board in February 2015 and requested an increase in Casper's participation from \$25,000 per year to \$35,000 per year. The additional funding was requested to help pay for increasing costs of programs including cultural resources technical support. In addition, the District requested capital funding in the amount of \$200,000 over a four year period to be used for the installation of pipelines, sprinkler irrigation systems, and other Selenium Control Best Management Practices (BMP's) throughout the watershed. The CPU Advisory Board recommended the amount of \$85,000 (\$35,000 for operations; \$50,000 for capital) be included in the FY16 – FY19 Public Utilities budgets.

The District attended the March 2023 CPU Advisory Board requesting funding in the amount of \$40,000. This is the same amount that was approved in FY's 2021 and 2022. The funding is to be used for direct and operational costs allowing the District to continue to manage active grants, apply for new grant opportunities, manage and implement ongoing irrigation BMPs, continue water quality programs, educational programs, and maintain public services and tree program. The \$40,000 FY23 funding request was approved by the CPU Advisory Board at their March 22, 2023 meeting.

Financial Considerations

Funding for this agreement will be from the Wastewater Treatment Plant Fund (\$35,000) and the Water Fund (\$5,000).

Oversight/Project Responsibility

The agreement will be administered by Bruce Martin, Public Utilities Manager.

Attachments

Resolution

Agreement

**AGREEMENT BETWEEN THE CITY OF CASPER AND
THE NATRONA COUNTY CONSERVATION DISTRICT**

THIS AGREEMENT is made and entered into this 2 day of May, 2023, by and between the City of Casper, Wyoming, a municipal corporation, 200 North David Street, Casper, Wyoming 82601, hereinafter referred to as "City," and the Natrona County Conservation District, 5880 Enterprise Drive, Suite 100, Casper, Wyoming 82609, hereinafter referred to as "District."

WHEREAS, City is authorized to contract with certain agencies to provide various services within its jurisdiction, pursuant to Wyoming Statute § 15-1-111; and,

WHEREAS, the District and the City desire to enter into a contract for the District to provide the services described in this Agreement for the compensation as set forth below.

NOW, THEREFORE, in consideration of the mutual covenants, promises, and conditions set forth hereunder, the parties agree as follows:

1. The terms of the Agreement shall be for a period of twelve (12) months, commencing April 1, 2023, and terminating March 31, 2024.
2. The parties agree that the total contract price of services to be provided by District, shall be the sum of Forty Thousand Dollars (\$40,000.00), payable to District upon receipt of a signed City voucher.
3. District agrees to utilize funding provided via this Agreement for direct and administrative costs for the purposes expressed in the Natrona County Conservation District FY2022 Annual Report and the FY2023 Annual Plan as attached hereto and incorporated herein as Exhibit "A".
4. District shall keep and maintain proper records, and shall make an annual financial report to City following the close of the 2023 Fiscal Year. District shall make quarterly reports to the City throughout the 2024 Fiscal Year.
5. District agrees to comply with all applicable federal, state, and local laws and regulations and covenants not to discriminate or engage in any practice that has the effect of discriminating against any person on the basis of race, color, national origin, sex, age, or disability, in furnishing or by refusing to furnish to such person or persons the use of any facility or participation in any program including any and all services, privileges, accommodations, and activities provided thereby. District agrees to give written assurances to City of steps taken to ensure an absence of discrimination against the participants in its programs and activities.

6. District agrees to procure and maintain public liability and property damage insurance in amounts not less than Two Hundred Fifty Thousand Dollars (\$250,000.00), for any claimant for any number of claims arising out of a single transaction or occurrence. Five Hundred Thousand Dollars (\$500,000.00) for all claims of all claimants arising out of a single transaction or occurrence, and Fifty Thousand Dollars (\$50,000.00) for property damage coverage. All policies shall provide that they are primary coverage without any right of contribution from any other insurance policy or other sources of the City, and that they will not be cancelled without thirty (30) days prior written notice to City. District hereby agrees to provide the City with copies of said insurance policies and/or certificates of insurance attesting to said coverage upon the execution of this Agreement. The intent of this section is to insure that sufficient funds are available to fully insure City for the full amounts of its potential liability under the Wyoming Governmental Claims Act, W.S. § 1-39-101 et seq. District hereby agrees to carry Workers' Compensation coverage for its employees in the amounts and limits as provided by Wyoming law with proof of coverage being provided to the City as described above.
7. District agrees to promptly pay, as they become due, all claims, debts, and charges, which it may incur as a result of the program herein contained, and shall hold and save City harmless of any such claims and debts.
8. The City and the District do not waive any right or rights they may have pursuant to the Wyoming Governmental Claims Act, W.S. § 1-39-101 et seq., and the City and the District specifically reserve the right to assert any and all rights, immunities, and defenses they may have pursuant to the Wyoming Governmental Claims Act.
9. This Agreement shall be binding upon the parties hereto, their respective successors, and assigns.

[The rest of this page is intentionally left blank.]

EXECUTED the day and year first set forth above.

APPROVED AS TO FORM:



ATTEST:

CITY OF CASPER, WYOMING
A Municipal Corporation

Fleur Tremel
City Clerk

Bruce Knell
Mayor

WITNESSETH:

NATRONA COUNTY
CONSERVATION DISTRICT

DocuSigned by:

3B589E8E8D934A4... _____

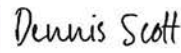
DocuSigned by:

E8DAB0CC38F047C... _____

By: Lisa Ogden, District Manager

Dennis Scott
Chairman

EXHIBIT "A"

Natrona County

Conservation District

(In Partnership with NC NRCS)

FY2022 Accomplishments in a Glance

Water Quality & Water Quantity ~

- ⌘ 128 acres converted from flood irrigation to sprinklers
- ⌘ 9,786 feet of dirt ditch replaced with 10,441 feet of pipeline
- ⌘ 94 acres of irrigated water management BMPs
- ⌘ Monthly water quality sampling and analysis for total selenium at 11 sites, along with field and flow measurements



Soil Health ~

- ⌘ Soil health principles implemented on 94 acres
- ⌘ Field day with board members and land owners



Rangeland Health ~

- ☞ 7 livestock/wildlife wells installed
- ☞ 14 livestock/wildlife tanks installed
- ☞ Livestock/wildlife water made available to 25,586 acres



Education ~

- ☞ Spoke with 100s of people at the Central Wyoming Home Show booth
- ☞ Field and office visits with landowners to answer questions about trees, irrigation systems, soil health, and other conservation questions



Seedling Tree Sales ~

- ☞ 7,220 seedling trees sold for shelterbelts, wildlife habitat and windbreaks
- ☞ 628 perennial natives species sold

Natrona County Conservation District

Integrated FY2022 Annual Report & FY2023 Annual Plan

Conserving our natural resources while
preserving our way of life.



Introducing Natrona County Conservation District

NCCD Priorities:

- ⌘ **Locally Led & Realistic Conservation**
- ⌘ **Overall Health of the Watershed**
- ⌘ **Water Quality & Quantity**
- ⌘ **Proper Soil Management**
- ⌘ **Rangeland Quality**
- ⌘ **Landowner Education & Technical Assistance**
- ⌘ **Ongoing Partnership Development**
- ⌘ **Voluntary Landowner Participation**
- ⌘ **Conservation Seedling Tree Sales**

**Natrona County
Conservation District**
5880 Enterprise Drive, Suite 100
Casper, Wyoming 82609
307.261.5436 Ext. 4

~~~~~  
[lisa.ogden@wy.nacdnet.net](mailto:lisa.ogden@wy.nacdnet.net)  
[www.nccdwyoming.com](http://www.nccdwyoming.com)



## NCCD Board of Supervisors & Staff

Back Row (Left to Right):

**Andy Anderson**—Supervisor, **Dennis Scott**—Chairman

Front Row (Left to Right):

**Ric Herman**— Vice-Chairman, **Scott Smith**—Supervisor,  
**Tammy Cobb**—Treasurer, **Kenny Wolfley**—NRCS District  
Conservationist, **Lisa Ogden**—NCCD District Manager

# Watershed Health, Water Quality and the NCCD

## (Why we do what we do....)

Total watershed health is the top priority for the Natrona County Conservation District (NCCD). Watershed health includes all aspects of water quality (both chemical and biological), water availability, soil health and management, as well as rangeland quality. The NCCD works to maintain and improve the health of the watershed by implementing best management practices (BMPs) that are determined to be an effective and realistic means of preventing or reducing the amount of pollution generated by nonpoint sources to a level compatible with water quality goals.

Large deposits of Cody Shale are prevalent in the underlying geology of much of Natrona County. As a result, large concentrations of the heavy metal selenium are abundant within the soil. Due to the metal's characteristic of being highly soluble in water, the North Platte River and its associated drainages are quite vulnerable to high levels of selenium. The BMPs that are implemented by landowners in partnership with NCCD are primarily focused on the reduction of selenium transportation through the watershed, but also emphasize protection of water quality and promotion of soil conservation within our watershed.

For more information regarding the watershed and the efforts of the NCCD, please visit our website at [www.nccdwyoming.com](http://www.nccdwyoming.com).



## Water Quality, Water Quantity & Rangeland Health Projects

### Completed Projects in FY2022 —

- Flood to Sprinkler ~ 128 Acres
- Earthen Ditch Eliminated ~ 9,786 Feet
- Irrigation Pipeline Installed ~ 10,441 Feet
- Irrigation Water Management ~ 94 Acres
- Wildlife/Stock Wells ~ 7
- Wildlife/Stock Pipeline ~ 2,861 Feet
- Wildlife/Stock Watering Facilities ~ 14
- Wildlife/Stock Water to 25,586 Acres



### Projected Projects for FY2023 —

- Flood to Sprinkler ~ 300 Acres
- Earthen Ditch Eliminated ~ 10,000 Feet
- Pipeline Installed ~ 10,000 Feet
- Irrigation Water Management ~ 200 Acres
- Wildlife/Stock Wells ~ 6
- Wildlife/Stock Pipeline ~ 10,000 Feet
- Wildlife/Stock Watering Facilities ~10

### Water Quality Sampling —

Monthly water quality sampling took place in FY2022 and continues into FY2023. The NCCD samples 11 different locations in the Middle North Platte River Watershed for total selenium. Annual water quality reports are compiled and reviewed for quality assurance by a licensed environmental engineering firm, as well as Wyoming Department of Environmental Quality. Overall water quality has continued to improve on a yearly basis at most of our sampling sites.

## Soil Health Projects ~

### Actual FY2022 —

- ☞ Implemented long-term soil health principles on 94 acres, including landowner education on armoring the soil, minimizing disturbance, plant diversity, continuous live plant/root, and livestock integration;
- ☞ Hosted a field day for board members and landowners on summer cover crops.



### Projected FY2023—

- ☞ NCCD will continue to work with landowners to implement soil health practices on additional acreage.

## Educational ~

### Actual FY2022 —

- ☞ Staffed a booth at the 2022 Home & Garden Show to promote the NCCD, answering resident and landowner questions, speaking to 100s of people.



### Projected FY2023 —

- ☞ NCCD will co-host Central Wyoming Tree School in Fall of 2022 for arborists and landowners;
- ☞ NCCD will co-host Casper Mountain Education Days in the Spring of 2023 for Casper Mountain landowners;
- ☞ Soil health field days.



## Seedling Tree Sales ~

### Actual FY2022—

- ☞ Sold 7,220 trees at affordable prices to over 100 landowners to establish shelterbelts, wildlife habitat and windbreaks;
- ☞ Assisted landowners with planning shelterbelts and tree selection;
- ☞ Sold 628 perennial native flowers to 18 landowners.

### Projected FY2023—

- ☞ The FY2023 Tree Program will see another 5,000 to 7,000 trees planted in Natrona County. The NCCD will continue to provide information on tree selection, planting techniques, and shelterbelt design in Natrona County.



## NCCD Budget Summary

### NCCD Financials

|                                                                      | FY2022<br>Actual  | FY2023<br>Budget  |
|----------------------------------------------------------------------|-------------------|-------------------|
| <b>Beginning of Fiscal Year (FY)</b>                                 |                   |                   |
| Reserves                                                             | \$ 274,199        | \$ 324,199        |
| General Funds                                                        | \$ 57,834         | \$ 79,855         |
| <b>All Cash on Hand Beginning of FY</b>                              | <b>\$ 332,033</b> | <b>\$ 404,054</b> |
| <b>Revenue</b>                                                       |                   |                   |
| Local Support (City of Casper/Natrona County)                        | \$ 80,000         | \$ 80,000         |
| State Support (WDA WQ Base & Lab Funds)                              | \$ 13,375         | \$ 12,825         |
| Gross Retail Sales                                                   | \$ 15,833         | \$ 12,000         |
| Grants (WDEQ319, WWDC, SWPP, WDA, WNRf)                              | \$ 86,498         | \$ 160,000        |
| Special Projects (Selenium Funds)                                    | \$ 50,000         | \$ 50,000         |
| Interest                                                             | \$ 91             | \$ 150            |
| <b>Total FY Revenue</b>                                              | <b>\$ 245,797</b> | <b>\$ 314,975</b> |
| <b>Expenditures</b>                                                  |                   |                   |
| Administration (Personnel, Board & Office Exp.)                      | \$ 62,381         | \$ 85,000         |
| Operations (BMPs, Retail Costs, Educational)                         | \$ 100,391        | \$ 416,119        |
| Indirect (Insurance, Indirect Payroll Costs)                         | \$ 12,353         | \$ 13,055         |
| <b>Subtotal</b>                                                      | <b>\$ 175,125</b> | <b>\$ 514,174</b> |
| Difference in End of Year Liabilities                                | \$ (1,349)        |                   |
| <b>Total FY Expenditures</b>                                         | <b>\$ 173,776</b> | <b>\$ 514,174</b> |
| <b>Total Cash on Hand Fiscal Year End (FYE)</b>                      | <b>\$ 404,054</b> | <b>\$ 204,855</b> |
| <b>End of Fiscal Year (FYE)</b>                                      |                   |                   |
| FYE Balance of Capital Reserves                                      | \$ 15,000         | \$ 30,000         |
| FYE Balance of Restricted Reserves (Pre-Paid Grants & Project Funds) | \$ 249,199        | \$ 30,000         |
| FYE Balance of Emergency Reserves (1 Year Operating Costs)           | \$ 60,000         | \$ 60,000         |
| <b>Total Reserves FYE</b>                                            | <b>\$ 324,199</b> | <b>\$ 120,000</b> |
| <b>NCCD General Fund at FYE</b>                                      | <b>\$ 79,855</b>  | <b>\$ 84,855</b>  |

For further information, please visit our website, [www.nccdwyoming.com](http://www.nccdwyoming.com), or call  
307.261.5436, Ext. 4.



RESOLUTION NO. 23-85

A RESOLUTION AUTHORIZING AN AGREEMENT  
BETWEEN THE CITY OF CASPER AND THE NATRONA  
COUNTY CONSERVATION DISTRICT.

WHEREAS, the City of Casper has entered into previous agreements with the Natrona County Conservation District each year from 1993 through 2022; and,

WHEREAS, the Conservation District, through its programs, will provide benefits to the City of Casper; and,

WHEREAS, the City of Casper desires to enter into a new agreement with the Natrona County Conservation District.

NOW, THEREFORE, BE IT RESOLVED BY THE GOVERNING BODY OF THE CITY OF CASPER, WYOMING: That the Mayor is hereby authorized and directed to execute, and the City Clerk to attest, an agreement between the City of Casper and the Natrona County Conservation District in an amount not to exceed Forty Thousand Dollars (\$40,000).

BE IT FURTHER RESOLVED, that the City Manager is hereby authorized to make verified partial payments to the project as prescribed by the agreement for a total amount not to exceed Forty Thousand Dollars (\$40,000).

PASSED, APPROVED, AND ADOPTED this \_\_\_\_ day of \_\_\_\_\_, 2023.

APPROVED AS TO FORM:

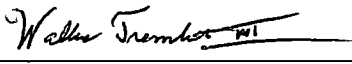
  
\_\_\_\_\_

ATTEST:

\_\_\_\_\_  
Fleur Tremel  
City Clerk

CITY OF CASPER, WYOMING  
A Municipal Corporation

\_\_\_\_\_  
Bruce Knell  
Mayor

April 3, 2023

MEMO TO: J. Carter Napier, City Manager 

FROM: Liz Becher, Community Development Director   
Scott Dresher, Casper Area Transit Manager  
Pam Jones, Grant Specialist

SUBJECT: Authorizing a Contract for Transportation Services between the City of Casper and the Town of Evansville for FY23 Transit Services

**Meeting Type & Date:** Regular Council Meeting, May 2, 2023

**Action Type:** Resolution

**Recommendation:**

That Council, by resolution, authorize a Contract for Transportation Services between the City of Casper and the Town of Evansville for FY23 Transit Services in the amount of \$35,214.92.

**Summary:**

Casper Area Transit originally drafted a Contract for Transportation Services with the Town of Evansville for LINK and ASSIST bus services for the period, July 1, 2022 through June 30, 2023. The City of Mills had concerns about the language in the Contract defining the municipality as a “Contractor.” A meeting was held with the attorneys for the other entities in Natrona County, and the Contract language was revised. After each entity approved the language, the Contract(s) were re-issued for the respective municipality, and the Contract for the Town of Evansville is attached hereto.

The City of Casper has enjoyed the ongoing relationship it has shared with the Town of Evansville for transit operations since assuming oversight in May 2021. The goal of Casper Area Transit is to keep the Casper area moving forward.

**Financial Considerations:**

In consideration of the performance of services rendered under this Contract, Casper Area Transit shall be compensated for services performed, not to exceed a sum of Thirty-Five Thousand Two Hundred Fourteen Dollars and Ninety-Two Cents (\$35,214.92) for FY23, with the rest of the funding to come from Federal and State grants to the City of Casper, and local funding from the optional one cent sales tax revenues.

**Oversight/Project Responsibility:**

Liz Becher, Scott Dresher, and Pam Jones – Casper Area Transit

**Attachments:**

Resolution  
Contract for Transportation Services

## **CONTRACT FOR TRANSPORTATION SERVICES**

This Contract for Transportation Services (“**Contract**”) is entered into on this \_\_\_\_ day of April, 2023, by and between the City of Casper (“**Casper**”), Wyoming, a Wyoming municipal corporation, 200 North David Street, Casper, Wyoming 82601 and the Town of Evansville (“**Evansville**”), Wyoming, a Wyoming municipal corporation, 235 Curtis Street, Evansville, Wyoming 82636.

Throughout this document, Casper and Evansville may be collectively referred to as the “parties.”

### **RECITALS**

**WHEREAS**, Casper is undertaking a project to support transit services within the boundaries of Natrona County, Wyoming which are near to it, and which are accordingly also outside of city limits of the City of Casper; and

**WHEREAS**, the project requires Transportation services for the demand response and fixed route transportation for Evansville and members of its general public; and

**WHEREAS**, Casper represents that it is ready, willing, and able to provide the Transportation services to Evansville as required by this Contract; and

**WHEREAS**, Evansville desires to contract with Casper for the provision of such services.

**NOW, THEREFORE**, in consideration of the covenants and conditions set forth herein to be performed, the parties agree as follows:

### **PART I. GENERAL TERMS AND CONDITIONS**

1. **SCOPE OF SERVICES:**

Casper, through its Casper Community Development Department, shall be responsible for administering this Contract and providing grant administration services. The Community Development Director is City Manager's authorized representative and shall so serve as liaison to Evansville.

Casper shall perform the following services in connection with and respecting the project:

- A. Casper shall operate a demand response transportation system for the urbanized area of Evansville. Casper shall place an emphasis on services for the elderly and disabled.
- B. Casper shall operate a fixed route transportation system for the general public

within the boundaries of Evansville

- C. Casper shall provide a demand response transportation service, at a minimum, from 6:30 a.m. to 6:30 p.m. on Monday through Friday, and on Saturday from 7:30 a.m. to 3:30 p.m.; provided, however, that Casper may discontinue transportation on the following holidays: New Year's Day, Memorial Day, Fourth of July, Labor Day, Thanksgiving Day, and Christmas Day; or, other holidays as deemed appropriate by Casper.
- D. Casper shall provide a fixed route transportation service, at a minimum, from 6:30 a.m. to 6:30 p.m. on Monday through Friday. Casper may discontinue fixed route transportation on the following holidays: New Year's Day, Memorial Day, Fourth of July, Labor Day, Thanksgiving Day, and Christmas Day; or, other holidays as deemed appropriate by Casper.
- E. Casper shall promote the services offered through appropriate informational programs.
- F. Casper shall provide such other related services, which from time to time, may be mutually agreed upon in writing by the parties hereto.
- G. Fares:
  - i. Fares and methods of fare payment charged to passengers and attendants shall be set by Casper; provided, however, that pursuant to Section 5(m) of the Urban Mass Transportation Act of 1964, fares charged elderly and disabled persons shall not exceed one half of the fares charged to the general public. The cash fares paid by passengers and/or service contracts shall be the property of Casper and considered program income. Casper has the option to alter fares during the course of the Contract. Casper will notify Evansville of its plans to implement its fare changes sixty (60) days in advance of the proposed fare change. For the purpose of this Contract, the demand response fare shall be Two Dollars (\$2.00) for the elderly and disabled and Five Dollars (\$5.00) for the general public per trip. Children twelve (12) years of age and younger shall ride for One Dollar (\$1.00) as long as they are accompanied by a parent or guardian. The fare shall continue until such time as amended by Casper.
  - ii. General fixed route fare is One Dollar (\$1.00) per trip, Student fare is Seventy-Five cents (\$0.75) per trip, reduced fare is Fifty cents (\$0.50) and children five (5) years and under are free. While the general fixed route fares are set by Casper, the criteria for reduced fare are determined by the Americans with Disabilities Act.
  - iii. A route deviation is \$1.00 for the elderly, disabled, or Medicare recipients. A route deviation is \$2 for the general public.

H. Group Trips

- i. Evansville shall notify the Community Development Director in writing of all special group trip requests at least ten (10) days in advance. Use of transit vehicles by Casper staff is permitted under certain conditions. Casper may use transit vehicles for non-transit related purposes for up to eighty (80) hours per year under 49 CFR Part 604.
- ii. Casper agrees to provide said service at the average hourly operating rate plus ten percent (10%) for additional costs and overhead.

2. TIME OF PERFORMANCE:

The services of Casper shall be undertaken on July 1, 2022, and completed on or before the 30th day of June 2023.

3. COMPENSATION:

- A. In consideration of the performance of services rendered under this Contract, Casper shall be compensated for services performed in accordance with paragraph 1, not to exceed a sum of Thirty-Five Thousand Two Hundred Fourteen Dollars and Ninety-Two Cents (\$35,214.92 ) for FY 2023. See Exhibit A, attached hereto and made part of this Contract.
- B. This Contract is specifically made subject to Casper receiving funding from the United States Department of Transportation, Federal Transit Administration (FTA). In the event that Casper fails to receive any of the aforementioned funds or has insufficient local match required for the grants, this Contract shall be subject to modification or termination as provided by the Terms and Conditions herein.
- C. This Contract is specifically made subject to the Council-approved FY 2023 budget, related, but not limited to, Casper's General Fund and Casper's 1% #16 Fund. If budget amendments occur that reduce this Contract's Compensation for services, found in Section 3, then this Contract's Scope of Services, found in Section 1, may also be amended by ways of, but not limited to, service reductions, reduced hours, or fixed-route system modifications.
- D. Evansville will be invoiced by Casper on a monthly basis based on the days and hours of service and the cost per service hour. Evansville will pay Casper the invoiced monthly amount for transit operations up to an amount not to exceed Thirty-Five Thousand Two Hundred Fourteen Dollars and Ninety-Two Cents (\$35,214.92) no later than July 31, 2023. Casper shall provide a monthly invoice broken out by days and hours of service and cost per service hour.

4. METHOD OF PAYMENT:

Evansville's payment will be made following completion of the terms set forth herein and receipt of an itemized invoice, certified under penalty of perjury, from Casper for services rendered in conformance with the Contract.

5. EXTENT OF CONTRACT:

This Contract represents the entire and integrated Agreement between Casper and Evansville, and supersedes all prior negotiations, representations, or agreements, either written or oral. The Contract may be amended only by written instrument signed by both Casper's and Evansville's authorized representatives.

Casper and Evansville each individually represent that they have the requisite authority to execute this Contract and perform the services described in this Contract.

6. TERMINATION OF CONTRACT:

- A. Casper may terminate this Contract anytime by providing thirty (30) days written notice to Evansville of intent to terminate said Contract. In such event, all finished or unfinished documents, data, studies and reports prepared by Casper under this Contract shall, at the option of Casper, become its property, and the Contractor shall be entitled to receive just and equitable compensation for any satisfactory work completed on such documents.
- B. Notwithstanding the above, Evansville shall not be relieved of liability to Casper for damages sustained by Casper, by virtue of termination of the Contract by Evansville, or any breach of the Contract by Evansville, and Casper may withhold any services for the purpose of setoff until such time as the exact amount of damages due Casper from Evansville are determined.

7. CHANGES:

Casper may, from time to time, request changes in the scope of the services of the Contract. Such changes, including any increase or decrease in the amount of compensation, which is mutually agreed upon between Casper and Evansville, shall be incorporated in written amendments to this Contract. There shall be no increase in the amount of compensation unless approved by Resolution adopted by Casper.

8. ASSIGNABILITY:

This Contract may not be assigned without the prior written approval of both parties hereto.

9. AUDIT:

Casper and its representatives shall have access and obtain at its discretion, copies to any books, documents, papers, electronic data and records of Evansville, which are pertinent to this Contract. Evansville shall immediately, upon receiving written instruction from Casper, provide to any independent auditor or accountant all books, documents, papers, electronic data and recordings of Evansville which are pertinent to this Contract. Evansville shall cooperate fully with any such independent auditor or accountant during the entire course of any audit authorized by Casper.

10. EQUAL EMPLOYMENT OPPORTUNITY:

In carrying out the program, no party hereto shall discriminate against any employee or applicant for employment because of race, color, religion, sex, national origin, or disability. The parties shall take affirmative action to ensure that applicants for employment are employed, and that employees are treated during employment, without regard to their race, color, religion, sex, national origin, or disability. Such action shall include, but not be limited to, the following: employment upgrading, demotion, or transfer; recruitment or recruitment advertising; layoff or termination; rates of pay or other forms of compensation; and selection for training, including apprenticeship. Casper shall post in conspicuous places, available to employees and applicants for employment, notices required by the government setting forth the provisions of this nondiscrimination clause. Casper shall state that all qualified applicants will receive consideration for employment without regard to race, color, religion, sex, national origin, or disability.

11. OWNER OF PROJECT MATERIALS:

All finished or unfinished documents, data, studies, surveys, drawings, maps, models, photographs, films, duplicating plates, and reports prepared under this Contract shall be considered the property of Casper, and upon completion of the services to be performed, or termination of this agreement, they will be turned over to Casper provided that, in any case, Evansville may, at no additional expense to Casper, make and retain such additional copies thereof as Evansville desires for its own use; and provided further, that in no event may any of the documents, data, studies, surveys, drawings, maps, models, photographs, films, duplicating plates, or other reports retained by Evansville be released to any person, agency, corporation, or organization without the written consent of Casper, except as may be required at law.

12. FINDINGS CONFIDENTIAL:

All reports, information, data, etc., given to or prepared, or assembled by Evansville under this Contract are confidential and shall not be made available to any individual or organization by Evansville without the prior written consent of Casper, except as otherwise required at law.

13. GOVERNING LAW AND VENUE:

This Contract shall be governed by the laws of the State of Wyoming. The Courts of the State of Wyoming shall have jurisdiction over this Contract and the parties. The venue shall be the Seventh Judicial District, Natrona County, Wyoming. The Parties shall also comply with all applicable laws, ordinances, and codes of the local, state, or federal governments and shall not trespass on any public or private property in performing any of the work embraced by this Contract.

14. INSURANCE AND INDEMNIFICATION:

Each party to this Contract shall assume the risk of any liability arising from its own conduct. Neither party agrees to insure, defend or indemnify the other.

Nothing in this Contract is intended to waive Casper's governmental immunity, or that of Evansville. Casper and Evansville do not waive any right or rights they may have pursuant to the Wyoming Governmental Claims Act, Wyoming Statutes Section 1-39-101 *et seq.*, and Casper specifically reserves the right to assert any and all rights, immunities, and defenses it may have pursuant to the Wyoming Governmental Claims Act.

15. NO THIRD PARTY BENEFICIARY RIGHTS:

The parties to this Contract do not intend to create in any other individual or entity the status of third-party beneficiary, and this Contract shall not be construed so as to create such status. The rights, duties and obligations contained in this Contract shall operate only between the parties to this Contract, and shall inure solely to the benefit of the parties to this Contract. The parties to this Contract intend and expressly agree that only parties signatory to this Contract shall have any legal or equitable right to seek to enforce this Contract, to seek any remedy arising out of a party's performance or failure to perform any term or condition of this Contract, or to bring an action for the breach of this Contract.

16. FORCE MAJEURE:

Neither party shall be liable for failure to perform under this Contract if such failure to perform arises out of causes beyond the control and without the fault or negligence of the nonperforming party. Such causes may include, but are not limited to, acts of God or the public enemy, fires, floods, epidemics, pandemics, quarantine restrictions, freight embargoes, and unusually severe weather. This provision shall become effective only if the party failing to perform immediately notifies the other party of the extent and nature of the problem, limits delay in performance to that required by the event, and takes all reasonable steps to minimize delays.



17. ELECTRONIC SIGNATURES:

The parties understand and agree that they have the right to execute this Contract through paper or through electronic signature technology, which is in compliance with Wyoming and federal law governing electronic signatures. The parties agree that to the extent they sign electronically, their electronic signature is the legally binding equivalent to their handwritten signature. Whenever they execute an electronic signature, it has the same validity and meaning as their handwritten signature. They will not, at any time in the future, repudiate the meaning of their electronic signature or claim that their electronic signature is not legally binding. They agree not to object to the admissibility of this Contract as an electronic record, or a paper copy of an electronic document, or a paper copy of a document bearing an electronic signature, on the grounds that it is an electronic record or electronic signature or that it is not in its original form or is not an original. Each party will immediately request that their electronic signature be revoked in writing if they discover or suspect that it has been or is in danger of being lost, disclosed, compromised or subjected to unauthorized use in any way. If either party would like a paper copy of this Contract, they may request a copy from the other party, and the other party shall provide it.

18. EFFECTIVE DATE:

The effective date of this Contract shall be July 1, 2022.

19. INCORPORATION OF RECITALS.

The recitals set forth above are hereby incorporated herein at this point as if fully set forth as part hereof.

**PART II. FEDERAL TRANSIT ADMINISTRATION (FTA) REQUIRED CLAUSES**

To the extent applicable, federal requirements extend to third party Contractors and their subcontracts and sub agreements at every tier. Accordingly, the parties agree to meet the following federal requirements in order to enter into any contracts and agreements during the Contract term. In addition, the parties will agree to include, and to require that its subcontracts and sub agreements include, appropriate clauses in each subcontract and each sub agreements financed in whole or in part with financial assistance provided by the FTA under the Grant Agreement(s) or Cooperative Agreement(s) between Casper of Casper and the FTA.

1. ACCESS TO RECORDS AND REPORTS:

a. Record Retention. Casper will retain, and will require its subcontractors of all tiers to retain, complete and readily accessible records related in whole or in part to the Contract, including, but not limited to, data, documents, reports, statistics, sub-agreements, leases, subcontracts, arrangements, other third party agreements of any type, and supporting materials related to those records.

b. **Retention Period.** Casper agrees to comply with the record retention requirements in accordance with 2 C.F.R. § 200.333. Casper shall maintain all books, records, accounts and reports required under this Contract for a period of at not less than three (3) years after the date of termination or expiration of this Contract, except in the event of litigation or settlement of claims arising from the performance of this Contract, in which case records shall be maintained until the disposition of all such litigation, appeals, claims or exceptions related thereto.

c. **Access to Records.** Casper agrees to provide sufficient access to FTA and its Contractors to inspect and audit records and information related to performance of this Contract as reasonably may be required.

d. **Access to the Sites of Performance.** Casper agrees to permit FTA and its Contractors access to the sites of performance under this Contract as reasonably may be required.

## 2. CIVIL RIGHTS LAWS AND REGULATIONS:

Casper is an Equal Opportunity Employer. As such, Casper agrees to comply with all applicable federal civil rights laws and implementing regulations. Apart from inconsistent requirements imposed by Federal laws or regulations, Casper agrees to comply with the requirements of 49 U.S.C. § 5323(h) (3) by not using any Federal assistance awarded by FTA to support procurements using exclusionary or discriminatory specifications. Under this Agreement, Casper shall at all times comply with the following requirements and shall include these requirements in each subcontract entered into as part thereof.

a. **Nondiscrimination.** In accordance with Federal transit law at 49 U.S.C. § 5332, Casper agrees that it will not discriminate against any employee or applicant for employment because of race, color, religion, national origin, sex, disability, or age. In addition, Casper agrees to comply with applicable Federal implementing regulations and other implement requirements FTA may issue.

b. **Race, Color, Religion, National Origin, Sex.** In accordance with Title VII of the Civil Rights Act, as amended, 42 U.S.C. § 2000e *et seq.*, and Federal transit laws at 49 U.S.C. § 5332, Casper agrees to comply with all applicable equal employment opportunity requirements of U.S. Department of Labor (U.S. DOL) regulations, "Office of Federal Contract Compliance Programs, Equal Employment Opportunity, Department of Labor," 41 C.F.R. chapter 60, and Executive Order No. 11246, "Equal Employment Opportunity in Federal Employment," September 24, 1965, 42 U.S.C. § 2000e note, as amended by any later Executive Order that amends or supersedes it, referenced in 42 U.S.C. § 2000e note. Casper agrees to take affirmative action to ensure that applicants are employed, and that employees are treated during employment, without regard to their race, color, religion, national origin, or sex (including sexual orientation and gender identity). Such action shall include, but not be limited to, the following: employment, promotion, demotion or transfer, recruitment or recruitment advertising, layoff or termination; rates of pay or other forms of compensation; and selection for training, including apprenticeship. In addition, Casper agrees to comply with any implementing requirements FTA may issue.

c. **Age.** In accordance with the Age Discrimination in Employment Act, 29 U.S.C. §§ 621-634, U.S. Equal Employment Opportunity Commission (U.S. EEOC) regulations, “Age Discrimination in Employment Act,” 29 C.F.R. part 1625, the Age Discrimination Act of 1975, as amended, 42 U.S.C. § 6101 *et seq.*, U.S. Health and Human Services regulations, “Nondiscrimination on the Basis of Age in Programs or Activities Receiving Federal Financial Assistance,” 45 C.F.R. part 90, and Federal transit law at 49 U.S.C. § 5332, Casper agrees to refrain from discrimination against present and prospective employees for reason of age. In addition, Casper agrees to comply with any implementing requirements FTA may issue.

d. **Disabilities.** In accordance with section 504 of the Rehabilitation Act of 1973, as amended, 29 U.S.C. § 794, the Americans with Disabilities Act of 1990, as amended, 42 U.S.C. § 12101 *et seq.*, the Architectural Barriers Act of 1968, as amended, 42 U.S.C. § 4151 *et seq.*, and Federal transit law at 49 U.S.C. § 5332, Casper agrees that it will not discriminate against individuals on the basis of disability. In addition, Casper agrees to comply with any implementing requirements FTA may issue.

### 3. DISADVANTAGED BUSINESS ENTERPRISE (DBE):

DBE participation has not been established for this procurement. Casper shall not discriminate on the basis of race, color, national origin, or sex in the performance of this Contract. Casper shall carry out applicable requirements of 49 C.F.R. part 26 in the award and administration of DOT-assisted contracts. Failure by Casper to carry out these requirements is a material breach of this Contract, which may result in the termination of this Contract or such other remedy as Casper deems appropriate, which may include, but is not limited to:

- a. Withholding monthly progress payments;
- b. Assessing sanctions;
- c. Liquidated damages; and/or
- d. Disqualifying Casper from future bidding as non-responsible. 49 C.F.R. § 26.13(b).

### 4. ENERGY CONSERVATION:

Casper agrees to comply with mandatory standards and policies relating to energy efficiency, which are contained in the state energy conservation plan issued in compliance with the Energy Policy and Conservation Act.

### 5. GOVERNMENT-WIDE DEBARMENT AND SUSPENSION:

This Contract is a covered transaction for purposes of 49 CFR Part 29. As such, the Casper is required to verify that its principals, affiliates, and subcontractors are eligible to participate in this federally funded contract and are not presently declared by any Federal department or agency to be:

- a. Debarred from participation in any federally assisted Award;
- b. Suspended from participation in any federally assisted Award;

- c. Proposed for debarment from participation in any federally assisted Award;
- d. Declared ineligible to participate in any federally assisted Award;
- e. Voluntarily excluded from participation in any federally assisted Award; or
- f. Disqualified from participation in any federally assisted Award.

6. NO GOVERNMENT OBLIGATION TO THIRD PARTIES:

Casper and Evansville acknowledge and agree that, notwithstanding any concurrence by the Federal Government in or approval of the solicitation or award of the underlying Contract, absent the express written consent by the Federal Government, the Federal Government is not a party to this Contract and shall not be subject to any obligations or liabilities to Casper, Evansville or any other party (whether or not a party to that contract) pertaining to any matter resulting from the underlying Contract. Casper agrees to include the above clause in each subcontract financed in whole or in part with Federal assistance provided by the FTA. It is further agreed that the clause shall not be modified, except to identify the subcontractor who will be subject to its provisions.

7. PROGRAM FRAUD AND FALSE OR FRAUDULENT STATEMENTS AND RELATED ACTS:

Casper acknowledges that the provisions of the Program Fraud Civil Remedies Act of 1986, as amended, 31 U.S.C. § 3801 *et seq.* and U.S. DOT regulations, "Program Fraud Civil Remedies," 49 C.F.R. part 31, apply to its actions pertaining to this Project. Upon execution of the underlying Contract, Casper certifies or affirms the truthfulness and accuracy of any statement it has made, it makes, it may make, or causes to be made, pertaining to the underlying contract or the FTA assisted project for which this Contract work is being performed. In addition to other penalties that may be applicable, Casper further acknowledges that if it makes, or causes to be made, a false, fictitious, or fraudulent claim, statement, submission, or certification, the Federal Government reserves the right to impose the penalties of the Program Fraud Civil Remedies Act of 1986 on Casper to the extent the Federal Government deems appropriate.

Casper also acknowledges that if it makes, or causes to be made, a false, fictitious, or fraudulent claim, statement, submission, or certification to the Federal Government under a contract connected with a project that is financed in whole or in part with Federal assistance originally awarded by FTA under the authority of 49 U.S.C. chapter 53, the Government reserves the right to impose the penalties of 18 U.S.C. § 1001 and 49 U.S.C. § 5323(l) on Casper, to the extent the Federal Government deems appropriate.

Casper agrees to include the above two clauses in each subcontract financed in whole or in part with Federal assistance provided by FTA. It is further agreed that the clauses shall not be modified, except to identify the subcontractors who will be subject to the provisions.

8. SAFE OPERATION OF MOTOR VEHICLES:

In compliance with Federal Executive Order No. 13043, "Increasing Seat Belt Use in the United States," April 16, 1997, 23 U.S.C. Section 402 note, Casper has adopted seat belt use and distracted driving policies and programs.

Seat Belt Use: Casper is encouraged to adopt and promote on-the-job seat belt use policies and programs for its employees and other personnel that operate company-owned vehicles, company-A-60 rented vehicles, or personally operated vehicles. The terms “company-owned” and “company-leased” refer to vehicles owned or leased either by Casper or Evansville.

Distracted Driving: Casper agrees to adopt and enforce workplace safety policies to decrease crashes caused by distracted drivers, including policies to ban text messaging while using an electronic device supplied by an employer, and driving a vehicle the driver owns or rents, a vehicle Contactor owns, leases, or rents, or a privately-owned vehicle when on official business in connection with the work performed under this Contract.

*\*The remainder of this page is intentionally left blank.\**

***City of Casper, Wyoming***  
***Signature Page***

Dated this \_\_\_\_\_ day of \_\_\_\_\_, 2023.

APPROVED AS TO FORM:

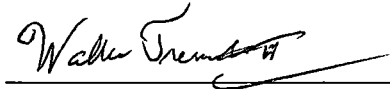
  
\_\_\_\_\_

ATTEST

CITY OF CASPER, WYOMING

\_\_\_\_\_  
Fleur Tremel

\_\_\_\_\_  
Bruce Knell, Mayor

**Town of Evansville, Wyoming**  
**Signature Page**

Dated this 24<sup>th</sup> day of April, 2023.

APPROVED AS TO FORM

\_\_\_\_\_

ATTEST

TOWN OF EVANSVILLE, WYOMING

  
Janelle Underwood, Town Clerk

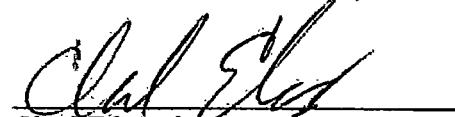
  
Chad Edwards, Mayor

# EXHIBIT A

## Transit Billing FY23 Forecast Town of Evansville

06/09/2022

| Month            | #days | Hours      | Cost per service hour<br>(fuel, maint., personnel) | Total        | Black Cat grant<br>56% of total | Balance<br>owed Casper |
|------------------|-------|------------|----------------------------------------------------|--------------|---------------------------------|------------------------|
|                  |       | <b>8.3</b> |                                                    |              |                                 |                        |
| July - 2022      | 20    | 166        | 37.52                                              | \$ 6,228.32  | \$ 3,487.86                     | \$ 2,740.46            |
| August - 2022    | 23    | 190.9      | 37.52                                              | \$ 7,162.57  | \$ 4,011.04                     | \$ 3,151.53            |
| September - 2022 | 21    | 174.3      | 37.52                                              | \$ 6,539.74  | \$ 3,662.25                     | \$ 2,877.48            |
| October - 2022   | 21    | 174.3      | 37.52                                              | \$ 6,539.74  | \$ 3,662.25                     | \$ 2,877.48            |
| November - 2022  | 21    | 174.3      | 37.52                                              | \$ 6,539.74  | \$ 3,662.25                     | \$ 2,877.48            |
| December - 2022  | 22    | 182.6      | 37.52                                              | \$ 6,851.15  | \$ 3,836.65                     | \$ 3,014.51            |
| January - 2023   | 22    | 182.6      | 37.52                                              | \$ 6,851.15  | \$ 3,836.65                     | \$ 3,014.51            |
| February - 2023  | 20    | 166        | 37.52                                              | \$ 6,228.32  | \$ 3,487.86                     | \$ 2,740.46            |
| March - 2023     | 23    | 190.9      | 37.52                                              | \$ 7,162.57  | \$ 4,011.04                     | \$ 3,151.53            |
| April - 2023     | 20    | 166        | 37.52                                              | \$ 6,228.32  | \$ 3,487.86                     | \$ 2,740.46            |
| May - 2023       | 22    | 182.6      | 37.52                                              | \$ 6,851.15  | \$ 3,836.65                     | \$ 3,014.51            |
| June - 2023      | 22    | 182.6      | 37.52                                              | \$ 6,851.15  | \$ 3,836.65                     | \$ 3,014.51            |
|                  |       |            |                                                    | \$ 80,033.91 | \$ 44,818.99                    | \$ 35,214.92           |



RESOLUTION NO. 23-86

A RESOLUTION AUTHORIZING A  
TRANSPORTATION SERVICES CONTRACT FOR  
TRANSIT SERVICES FOR THE TOWN OF  
EVANSVILLE, A WYOMING MUNICIPALITY, FOR  
FISCAL YEAR 2023.

WHEREAS, Casper is undertaking a project to support transit services within the boundaries of Natrona County, Wyoming which are near to it, and which are accordingly also outside of city limits of the City of Casper; and

WHEREAS, the project requires transportation services for the demand response and fixed route transportation for Evansville and members of its general public; and

WHEREAS, Casper represents that it is ready, willing, and able to provide the Transportation services to Evansville as required by this Contract; and

WHEREAS, Evansville desires to contract with Casper for the provision of such services.

NOW, THEREFORE, BE IT RESOLVED BY THE GOVERNING BODY OF THE CITY OF CASPER, WYOMING: That the Mayor is hereby authorized and directed to execute, and the City Clerk to attest, a Contract for Transportation Services between the City of Casper and the Town of Evansville, a Wyoming municipality, for Fiscal Year 2023, in an amount not to exceed Thirty-Five Thousand Two Hundred Fourteen Dollars and Ninety-Two Cents (\$35,214.92).

BE IT FURTHER RESOLVED: That the Contract amount for the Town of Evansville's financial obligation should not exceed Thirty-Five Thousand Thirty-Five Thousand Two Hundred Fourteen Dollars and Ninety-Two Cents (\$35,214.92) with the rest of the funding to come from Federal and State grants to the City and local funding.

BE IT FURTHER RESOLVED: That the Contract amount for the Town of Evansville's financial obligation shall be for only those funds necessary to operate the transit system in the Town of Evansville.

PASSED, APPROVED, AND ADOPTED on this \_\_\_ day of \_\_\_\_\_, 2023.

APPROVED AS TO FORM:

  
\_\_\_\_\_

ATTEST:

\_\_\_\_\_  
Fleur Tremel  
City Clerk

CITY OF CASPER, WYOMING  
A Municipal Corporation

\_\_\_\_\_  
Bruce Knell  
Mayor

April 26, 2023

**MEMO TO:** City Council  
J. Carter Napier, City Manager *JCN*

**FROM:** Eric K. Nelson, City Attorney *E. K. Nelson*  
Wallace Trembath, Deputy City Attorney *W. T.*

**SUBJECT:** **A Resolution Authorizing a Telephone Line Easement Agreement between the City of Casper, Wyoming and Natrona County, Wyoming.**

**Meeting Type & Date**

Regular Council Meeting

May 2, 2023

**Action type**

Resolution

**Recommendation**

That City Council adopt a Resolution Authorizing a Telephone Line Easement Agreement between the City of Casper, Wyoming and Natrona County, Wyoming.

**Summary**

City of Casper staff was recently approached by Natrona County who received a Nine Million Dollar (\$9,000,000) grant from the United States Department of Interior (Federal HWY 251) to upgrade the road surface of Circle Drive Road, also known as Wyoming State Highway No. 251. Century Link QC, has telephone lines in the project area that need to be relocated and the new location of the telephone lines will be partially on County owned land and City owned land managed by the County. A telephone line easement from the City is required by WYDOT and the United States Department of Interior for relocation of Century Link's telephone lines and without a telephone line easement, the County's project funding is at risk of recission.

Staff is requesting the City Council to grant the easement to assist the County for the benefit of the public by executing a Telephone Line Easement Agreement for the relocation of Century Link telephone lines. A map of the project area and proposed easement is attached to this Memo.

**Financial Considerations**

None. In the event the County's project does not move forward, the Easement will revert back to the City.

**Oversight/Project Responsibility**

Wallace Trembath, Deputy City Attorney

**Attachments**

Resolution

Telephone Line Easement Agreement

## TELEPHONE LINE EASEMENT AGREEMENT

This Telephone Line Easement Agreement (the “**Agreement**”) is made and entered into this \_\_\_\_ day of \_\_\_\_\_, 2023, by and between the City of Casper, Wyoming, (“**Grantor**”), a Wyoming municipal corporation, with offices located at 200 North David Street, Casper, Wyoming 82601, and Natrona County, Wyoming, (“**Grantee**”), with offices located at 200 North Center Street #211, Casper, Wyoming 82601. The Grantor and the Grantee may be individually referred to as a “**party**” or collectively referred to as the “**parties.**”

### RECITALS

A. Grantee received a nine-million-dollar (\$9,000,000) grant from the United States Department of Interior (Federal HWY 251) to upgrade the road surface of Circle Drive Road, also know as Wyoming State Highway No. 251 (“**the project**”).

B. Qwest Corporation, d/b/a Century Link QC (“**Century Link**”), has telephone lines in the project area that need to be relocated.

C. The new location of the telephone lines will be partially on Grantee-owned land and partially on Grantor-owned land managed by the Grantee.

D. A telephone line easement from the Grantor is required by WYDOT and the United States Department of Interior for relocation of Century Link’s telephone lines.

E. Without a telephone line easement, the Grantee’s project funding is at risk of rescission.

F. The governing body of the City of Casper has the authority granted by Wyoming State Statute § 15-10-113 (a) (i) to grant easements or other rights therein to a municipality, or county, or the federal government.

F. The City desires to assist the County in keeping its grant funding by executing a telephone line easement for the relocation of Century Link telephone lines.

**NOW THEREFORE**, in consideration of the sum of Ten Dollars (\$10.00) and other good and valuable consideration, the receipt of which is hereby acknowledged and confessed, the parties agree as follows:

1. The recitals set forth above are hereby incorporated herein at this point as if fully set forth as part hereof.

2. Grantor, hereby grants to the Grantee, a non- exclusive perpetual easement for the construction, maintenance, repair and replacement of Century Link’s telephone lines,

over, across, and under land located in the County of Natrona and State of Wyoming, ("Easement") which Easement is more particularly described and set forth in Exhibit "A" and Exhibit "B", attached hereto, the Exhibits being incorporated herein.

3. Grantor also grants the right of ingress and egress to and from the said land for all purposes necessary for laying out, constructing, inspecting, maintaining, and replacing the telephone lines located within the described Easement.

4. The Easement shall burden Grantor's property and benefit Grantees, their successors and assigns.

5. Grantor provides no warranty of title and the Easement is subject to reservations, restrictions, covenants and conditions of record and all rights of way and easements, whether of record or not.

6. Grantee shall, at its sole expense, restore all areas disturbed for the purposes of laying out, constructing, inspecting, operating, maintaining, and replacing Century Link telephone lines owned by it on the Easement property to pre-existing conditions, or better.

7. Grantor reserves unto itself such rights in the Easement property for any purpose which does not interfere with the Easement granted herein, and to create and grant such other easements, rights and privileges in, on, under, or across the easement to such persons or entities and for such purposes as Grantor may elect, provided that the purposes of any such additional easements, rights and privileges shall not be inconsistent with or unreasonably interfere with the Easement granted herein.

8. The Grantees shall not use the Easement for any use prohibited by or in violation of the terms of the Easement or applicable laws, rules or regulations. If the Easement is no longer used for the purpose described herein or is abandoned in writing by the Grantee or Century Link, then the Easement shall automatically and unconditionally terminate and all right granted shall revert to the then owner or owners of the property burdened by the Easement.

9. All provisions of the Easement, including the benefits and burdens, are appurtenant to and run with the land and are binding upon and inure to the benefit of the successors and assigns of the Grantor and Grantees.

10. Governmental Claims. Neither party waives any right or rights they may have pursuant to the Wyoming Governmental Claims Act, Wyoming Statutes Section 1-39-101

*et seq.*, and the parties specifically reserve the right to assert any and all rights, immunities, and defenses they may have pursuant to the Wyoming Governmental Claims Act.

**Grantor's Signature Page**

Approved as to Form:

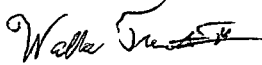

\_\_\_\_\_  
Attorney for the City of Casper

ATTEST:

CITY OF CASPER, WYOMING,  
A municipal corporation,

\_\_\_\_\_  
City Clerk

By: \_\_\_\_\_  
Bruce Knell  
Mayor

STATE OF WYOMING            )  
                                          ) ss.  
COUNTY OF NATRONA        )

This instrument was acknowledged before me on this \_\_\_\_\_ day of \_\_\_\_\_, 2023, by Bruce Knell, as Mayor of the City of Casper, Wyoming.

\_\_\_\_\_  
(Signature of notarial officer)

My Commission Expires: \_\_\_\_\_

**Grantee's Signature Page**

Approved as to Form:

\_\_\_\_\_  
Attorney for Natrona County

ATTEST:

NATRONA COUNTY, WYOMING,

\_\_\_\_\_  
County Clerk

By: \_\_\_\_\_  
Steven K. Freel  
Chairman

STATE OF WYOMING            )  
                                          ) ss.  
COUNTY OF NATRONA        )

This instrument was acknowledged before me on this \_\_\_\_\_ day of \_\_\_\_\_, 2023, by Steven K. Freel, as Chairman of the Natrona County Board of Commissioners.

\_\_\_\_\_  
(Signature of notarial officer)

My Commission Expires: \_\_\_\_\_



**Cover Page for Exhibit A  
(Legal Description of the Property)**



**Cover Page for Exhibit B  
(Map of the Property)**

WLC ENGINEERING & SURVEYING  
 200 PRONGHORN STREET, CASPER, WYOMING 82601  
 FOR

Exhibit B

Client NATRONA COUNTY ROAD & BRIDGE Address P.O. BOX 848  
 City MILLS State WYOMING Zip 82644

PROPERTY LOCATION PLAT

SE1/4SW1/4 Section 16, T. 32 N., R. 79 W., 6th Principal Meridian, Wyoming  
 County NATRONA State WYOMING

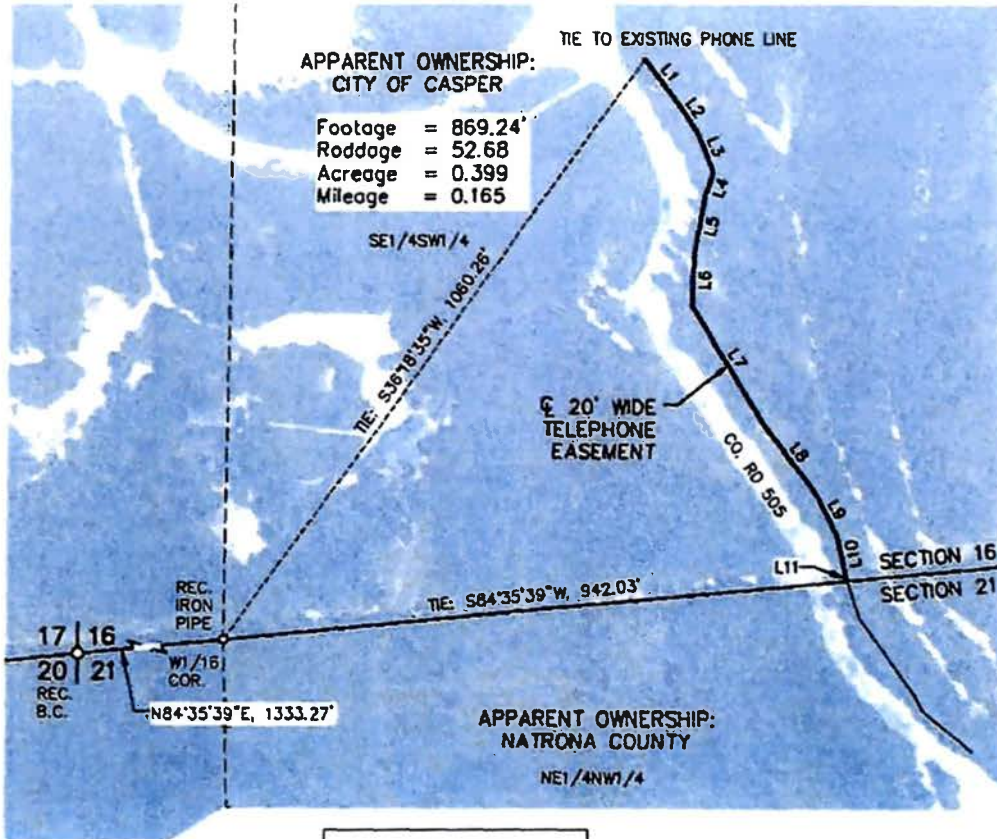

| Line Table |             |         |
|------------|-------------|---------|
| Line #     | Direction   | Length  |
| L1         | S37°09'46"E | 73.03'  |
| L2         | S35°03'38"E | 58.50'  |
| L3         | S23°46'08"E | 64.31'  |
| L4         | S20°30'13"W | 32.84'  |
| L5         | S10°56'51"W | 89.85'  |
| L6         | S27°1'59"W  | 75.50'  |
| L7         | S32°20'01"E | 207.64' |
| L8         | S37°48'40"E | 130.49' |
| L9         | S27°06'27"E | 67.89'  |
| L10        | S12°36'36"E | 62.12'  |
| L11        | S18°51'35"E | 7.07'   |



SCALE: 1"=200'

BASIS OF BEARING:  
 STATE PLANE COORDINATES  
 WYOMING EAST CENTRAL ZONE  
 NAD 83/2011  
 US SURVEY FOOT GRID DISTANCE

Date: 12-14-22  
 W.O. No. 17668  
 Book No.     , Pg.       
 Drawn By: MPJ  
 Acad File: TELEESMT



H:\CLIENT\NATRONA COUNTY ROAD & BRIDGE\17668-NCRB-BEARTRAP PHONE EASEMENT\SURVEY\DWG\TELEESMT.DWG

RESOLUTION NO. 23-87

A RESOLUTION AUTHORIZING A TELEPHONE LINE EASEMENT AGREEMENT BETWEEN THE CITY OF CASPER, WYOMING AND NATRONA COUNTY, WYOMING.

WHEREAS, Natrona County, Wyoming, received a Nine Million Dollar (\$9,000,000) grant from the United States Department of Interior (Federal HWY 251) to upgrade the road surface of Circle Drive Road, also known as Wyoming State Highway No. 251; and,

WHEREAS, Century Link QC, has telephone lines in the project area that need to be relocated and the new location of the telephone lines will be partially on County owned land and City owned land managed by the County; and,

WHEREAS, a telephone line easement from the City is required by WYDOT and the United States Department of Interior for relocation of Century Link's telephone lines; and,

WHEREAS, without a telephone line easement, the Grantee's project funding is at risk of rescission; and,

WHEREAS, the Governing Body of the City of Casper, Wyoming has the authority granted by Wyoming State Statute § 15-10-113 (a) (i) to grant easements or other rights therein to a municipality, or county, or the federal government; and,

WHEREAS, the City desires to assist the County for the benefit of the public by executing a Telephone Line Easement Agreement for the relocation of Century Link telephone lines.

NOW, THEREFORE, BE IT RESOLVED BY THE GOVERNING BODY OF THE CITY OF CASPER, WYOMING: that the Mayor is hereby authorized and directed to execute, and the City Clerk to attest a Telephone Line Easement Agreement between the City of Casper, Wyoming, and Natrona County, Wyoming.

PASSED, APPROVED, AND ADOPTED this \_\_\_ day of \_\_\_\_\_, 2023.

APPROVED AS TO FORM:

  
\_\_\_\_\_

ATTEST:

CITY OF CASPER, WYOMING  
A Municipal Corporation

---

Fleur Tremel  
City Clerk

---

Bruce Knell  
Mayor

April 15, 2023

**MEMO TO:** J. Carter Napier, City Manager *JCN*

**FROM:** Jolene Martinez, Assistant to the City Manager

**SUBJECT:** Authorizing Submission of a WaterSMART Aquatic Ecosystem Restoration Projects grant application in an amount up to \$2,000,000 for river restoration planning and design of the North Casper and Knife River Reaches of the North Platte River.

**Meeting Type & Date**

Council Meeting  
May 2, 2023

**Action Type**

Resolution

**Recommendation**

That Council, by resolution, authorize submission of a WaterSMART Aquatic Ecosystem Restoration Projects grant application in an amount up to \$2,000,000 for planning and design of river restoration work.

**Summary**

In June 2013, Council authorized staff to move forward to secure funding and implement the work identified in the Platte River Environmental Restoration Master Plan. The river restoration effort, which includes a volunteer day every September, is called the Platte River Revival. The projects outlined in the master plan are a combination of riverbank and in-river construction, Russian olive removal, and vegetative plantings. Seven in-river and riverbank construction projects were identified and four have been completed.

Grants and donations are integral to funding river restoration. A WaterSMART Aquatic Ecosystem Restoration Projects grant through the Bureau of Reclamation is available and due June 1, 2023. This grant program has a focus on aquatic ecosystem work and specifically names river restoration projects that improve aquatic and riparian habitat. The grant funds planning and design, which must be completed to 60% to subsequently apply for construction funding from the same grant program. The maximum that can be requested for planning and design is \$2 million and requires a minimum 35% cash and/or in-kind match. The North Casper and Knife River Reaches are eligible for this grant.

Casper has a valuable and unique asset in the North Platte River, and river restoration is a transformational investment in Casper's infrastructure. A showcased river with a planned and protected natural/urban interface prevents water pollution and improves water quality; improves aquatic and terrestrial habitat that may make Casper's urban corridor a destination fishery;

stabilizes and improves banks; and provides economic development opportunities. Additionally, river restoration is a quality of life project that can positively impact human health by providing a connection with nature.

**Financial Considerations**

To be eligible for construction funding from Federal grant sources, planning and design work at 60% completion is usually required. At an estimated restoration cost of \$23 million, the North Casper and Knife River Reaches would benefit from Federal funding, which is generally larger than most state and local funding sources. A planning and design cost for these reaches is being sought; however, the cost would not be more than two million, the maximum request amount from the WaterSMART Aquatic Ecosystem Restoration Projects grant program. The match will be in cash from a combination of River Fund reserves, other grants and donations and in-kind work from the City, volunteers, and other businesses, foundations, organizations, and agencies who have a track record of cooperating on the river restoration work.

**Oversight/Project Responsibility**

Jolene Martinez, Assistant to the City Manager  
Alex Sveda, City Engineer  
Scott Baxter, Associate Engineer

**Attachments**

Resolution



RESOLUTION NO. 23-88

A RESOLUTION AUTHORIZING SUBMISSION OF AN APPLICATION TO THE WATERSMART AQUATIC ECOSYSTEM RESTORATION PROJECTS GRANT PROGRAM

WHEREAS, the City of Casper has identified the need to restore the North Platte River through Casper and has identified the need to study and design restoration for two identified reaches of the river that will result in significant improvement to the aquatic ecosystem and provide regional benefits; and,

WHEREAS, the river restoration project will improve stream channel structure and complexity, improve flood plain connectivity, protect and stabilize riverbanks to reduce erosion, influence water temperature, improve riparian habitat, restore natural wetlands, divert stormwater flow into wetlands, and enhance river-based recreation; and,

WHEREAS, river restoration results in functioning aquatic ecosystems that provide habitat for fish and wildlife, improve water quality, store excess carbon, mitigate the impacts of drought and flood events, offer wide-ranging benefits for people, and support multiple water uses; and,

WHEREAS, the WaterSMART Aquatic Ecosystem Restoration Projects grant is designed to assist with funding study and design of aquatic ecosystem restoration projects and can provide up to \$2,000,000 with a match of at least 35% in cash and in-kind services; and,

WHEREAS, required grant match can be met with cash and in-kind work from a combination of River Fund reserves, other donations, and in-kind work from the City of Casper staff, volunteers, and other businesses, foundations, organizations and agencies who have a track record of cooperating on the river restoration work; and,

WHEREAS, the City of Casper has the legal authority to enter into an agreement with the U.S. Bureau of Reclamation; and,

WHEREAS, the Casper City Council supports the application and will review the contents prior to application; and,

WHEREAS, the City of Casper will work with the U.S. Bureau of Reclamation to meet established deadlines for entering into a grant or cooperative agreement.

NOW, THEREFORE, BE IT RESOLVED BY THE GOVERNING BODY OF THE CITY OF CASPER, WYOMING: That the Mayor is hereby authorized and directed to execute and the City Clerk to attest, an application to the WaterSMART Aquatic Ecosystem Restoration Projects grant program in the amount of up to \$2,000,000 for planning and design of two reaches of the river restoration project.

BE IT FURTHER RESOLVED: That the governing body of the City of Casper adopts the WHEREAS clauses set forth above for purposes complying with Section D.2.2.12 of the Notice of Opportunity No. R23AS00106.

PASSED, APPROVED AND ADOPTED this \_\_\_\_ day of \_\_\_\_\_, 2023.

APPROVED AS TO FORM:

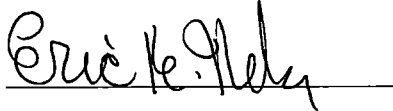

ATTEST:

\_\_\_\_\_  
Fleur D. Tremel  
City Clerk

CITY OF CASPER, WYOMING  
A Municipal Corporation

\_\_\_\_\_  
Bruce Knell  
Mayor

April 19, 2023

**MEMO TO:** J. Carter Napier, City Manager 

**FROM:** Zulima Lopez, Parks, Recreation, & Public Facilities Director  
Phil Moya, Recreation Manager

**SUBJECT:** Approval of a Wyoming Department of Family Services grant in the amount of \$156,500 for Casper Recreation Center Child Care Programs.

**Meeting Type & Date**

Regular Meeting  
May 2, 2023

**Action Type**

Resolution

**Recommendation**

That Council, by resolution, authorize the acceptance of a Wyoming Department of Family Services Child Stabilization Grant in the amount of One Hundred Fifty-Six Thousand Five Hundred Dollars (\$156,500) for Casper Recreation Center child care programs.

**Summary**

In November 2022 the City of Casper was informed of a Wyoming Department of Family Services grant opportunity intended to steady Wyoming's childcare network. The grant gives financial support to eligible child care providers that have experienced increased costs, disruptions, and challenges since March 2020. Funds were made available to Wyoming through the Child Care and Development Fund and appropriated through the American Rescue Plan Act (ARPA). The grant focuses on four (4) categories of building and supporting childcare through staff expansion and retention efforts, supporting physical space expansion, expansion of care for children, and establishing transportation options. Awarded funding is required to be spent by September 30, 2023.

Given public feedback from parents in the Recreation Center's child care (camp) programs, as well as the financial hardships and slow recovery the Recreation Center has experienced since the pandemic, City staff seized the opportunity to apply for the grant. Our application focused primarily on the need for funding to create additional space within the Recreation Center, safe transportation to programmed camp activities, updated camp supplies, and additional training for staff. The City's application was approved for One Hundred Fifty-Six Thousand Five Hundred Dollars (\$156,500).

Staff requests City Council approval to accept the Wyoming Child Care Stabilization funds and begin improvements at the Casper Recreation Center.

**Financial Considerations**

The full award of funds has been received from the Wyoming Department of Family Services. A budget amendment for the grant revenue and expenditures will be included as part of FY23 Budget Amendment #3.

**Oversight/Project Responsibility**

Phil Moya, Recreation Manager  
Jenniffer Harvey, Recreation Supervisor

**Attachments**

Resolution

RESOLUTION NO. 23-89

A RESOLUTION AUTHORIZING ACCEPTANCE OF A CHILD STABILIZATION GRANT FROM THE WYOMING DEPARTMENT OF FAMILY SERVICES IN THE AMOUNT OF ONE HUNDRED FIFTY-SIX THOUSAND FIVE HUNDRED DOLLARS.

WHEREAS, the City of Casper identified the need for growth in youth services and childcare programs provided by the Casper Recreation Center; and,

WHEREAS, the Department of Family Services offers Child Stabilization Grants to fund four (4) categories of building and supporting staff through: expansion and retention efforts, supporting physical space expansion, expansion of care for children, and establishing transportation options; and,

WHEREAS, the City of Casper applied and was awarded a Child Stabilization Grant from the Wyoming Department of Family Services, in the amount of One Hundred Fifty-Six Thousand Five Hundred Dollars (\$156,500); and,

WHEREAS, the City of Casper desires to accept the grant funds from the Wyoming Department of Family Services to support training for camp leaders, expand physical childcare space in the facility, provide enhanced childcare services for members and daily users, and provide transportation for camp programs.

NOW, THEREFORE, BE IT RESOLVED BY THE GOVERNING BODY OF THE CITY OF CASPER, WYOMING: That the grant from the Wyoming Department of Family Services, in the amount of One Hundred Fifty-Six Thousand Five Hundred Dollars (\$156,500) is hereby accepted.

PASSED, APPROVED AND ADOPTED this \_\_\_\_ day of \_\_\_\_\_, 2023.

APPROVED AS TO FORM:



ATTEST:

\_\_\_\_\_  
Fleur Tremel  
City Clerk

CITY OF CASPER, WYOMING  
A Municipal Corporation

\_\_\_\_\_  
Bruce Knell  
Mayor

April 25, 2023

MEMO TO: J. Carter Napier, City Manager *JCN*  
FROM: Jacob Black, Fire Chief  
Jason Speiser, Deputy Chief  
SUBJECT: Regional Response Grant #20 Amendment Two to Extend the Deadline  
Through August 31, 2024

**Meeting Type & Date**

Regular Council Meeting  
May 2, 2023

**Action type**

Resolution

**Recommendation**

That Council, by resolution, approve Amendment Two for Regional Response Grant #20.

**Summary**

Regional Response Grant #20 for \$109,000 was originally approved by Council on August 27, 2021 for the purpose of purchasing a self-loading container bed, cargo containers, and cargo container trailer. This project was sent out to bid, but came in over-budget, and therefore was determined to be unfeasible. A grant amendment was approved by the Wyoming Department of Homeland Security to change the scope of the grant to purchase a custom service body for a F550 chassis, and 8 Scott escape packs and associated equipment for confined space rescue. Due to production delays, this grant is being extended through August 31, 2024

**Financial Considerations**

None

**Oversight/Project Responsibility**

Jason Speiser; Deputy Chief

**Attachments**

Amendment Two Grant Award Agreement; Grant ID #20-SHSP-RR2-RR-HRT20.

APPROVAL AS TO FORM

I have reviewed the attached *Amendment Two to the Grant Award Agreement between Wyoming Office of Homeland Security and City of Casper*, and approve it as to form on behalf of the City of Casper, Wyoming.

Dated: April 20, 2023.

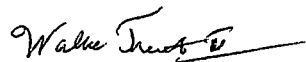

Wallace Trembath III  
Deputy City Attorney

**Contract #:** 229734

**Entry Date:** 3/14/2023 3:49:40 PM  
WYOMING ATTORNEY  
GENERAL'S OFFICE

3-28-23  
Jodi A. Darrough  
APPROVED AS TO FORM

**Department:** Wyoming Office of Homeland Security

**Agency Contact:** Erickson, Darryl (OHS)

**Phone:** 307-777-4917

**Other Agency Contact:**

**Client Comments:**

**Contractor/Vendor Name:** City of Casper

**Contract Title:** 20-SHSP-CAS-HRT20  
Amendment Two

**Contract Type:** Amendment

**Contract Amount:** 109000.0000

**Contract Effective Date:**

**Contract Expiration Date:** 8/31/2024 12:00:00 AM

**Status:** AG Approved as to Form

**RETURN VIA:** ~~Ink Signature Inter-agency Mail~~

**Assigned Attorney:** Jodi Darrough



**AMENDMENT TWO TO THE GRANT AWARD AGREEMENT BETWEEN  
WYOMING OFFICE OF HOMELAND SECURITY  
AND  
CITY OF CASPER**

1. **Parties.** This Amendment is made and entered into by and between the Wyoming Office of Homeland Security (Agency), whose address is: 5500 Bishop Blvd., Cheyenne, WY 82002 and City of Casper (Subrecipient), whose address is: 201 N. David Street 2<sup>nd</sup> Floor, Casper, WY 82601.
2. **Purpose of Amendment.** This Amendment shall constitute the second amendment to the Grant Award Agreement (Agreement) between the Agency and the Subrecipient. The purpose of this Amendment is to extend the term of the Agreement through August 31, 2024.

The original Agreement, dated August 27, 2021, allowed the Subrecipient to expend Grant funds for the purchase of a self-loading container bed, cargo containers, and a cargo container trailer for a total Agreement amount of one hundred nine thousand dollars and zero cents (\$109,000.00) with an expiration date of August 31, 2022.

Amendment One, dated July 11, 2022: a) extended the term of the Agreement through May 31, 2023; and b) replaced Attachment A, Project Description, with Attachment A-1, Updated Project Description.

3. **Term of the Amendment.** This Amendment shall commence upon the date the last required signature is affixed hereto (Effective Date), and shall remain in full force and effect through the term of the Agreement, as amended, unless terminated at an earlier date pursuant to the provisions of the Agreement, or pursuant to federal or state statute, rule, or regulation.
4. **Amendments.**
  - A. As of the Effective Date of this Amendment, all references to the end date of the Performance Period of the Agreement in the original Agreement, and in any amendments thereto, are amended to read: August 31, 2024.

5. **Amended Responsibilities of the Subrecipient.**

Responsibilities of the Subrecipient have not changed.

6. **Amended Responsibilities of the Agency.**

Responsibilities of the Agency have not changed.

7. **Special Provisions.**

- A. Same Terms and Conditions.** With the exception of items explicitly delineated in this Amendment, all terms and conditions of the original Agreement, and any previous amendments, between the Agency and the Subrecipient, including but not limited to sovereign immunity, shall remain unchanged and in full force and effect.
- B. Counterparts.** This Amendment may be executed in counterparts. Each counterpart, when executed and delivered, shall be deemed an original and all counterparts together shall constitute one and the same Amendment. Delivery by the Subrecipient of an originally signed counterpart of this Amendment by facsimile or PDF shall be followed up immediately by delivery of the originally signed counterpart to the Agency.

**8. General Provisions.**

- A. Entirety of Agreement.** The original Agreement, consisting of eighteen (18) pages; Attachment A, Project Description, consisting of one (1) page; Amendment One, consisting of three (3) pages; Attachment A-1, Updated Project Description, consisting of one (1) page, and Amendment Two, consisting of three (3) pages, represent the entire and integrated agreement between the parties and supersede all prior negotiations, representations, and agreements, whether written or oral.

**THE REMAINDER OF THIS PAGE WAS INTENTIONALLY LEFT BLANK.**

9. **Signatures.** The parties to this Amendment, through their duly authorized representatives, have executed this Amendment on the dates set out below, and certify that they have read, understood, and agreed to the terms and conditions of this Amendment.

This Amendment is not binding on either party until approved by A&I Procurement and the Governor of the State of Wyoming or his designee, if required by Wyo. Stat. § 9-2-3204(b)(iv).

**AGENCY: WYOMING OFFICE OF HOMELAND SECURITY**

\_\_\_\_\_  
Lynn Budd, Director

\_\_\_\_\_  
Date

**SUBRECIPIENT: CITY OF CASPER**

\_\_\_\_\_  
Subrecipient Designee Signature

\_\_\_\_\_  
Date

\_\_\_\_\_  
Attested by:

\_\_\_\_\_  
Date

**ATTORNEY GENERAL'S OFFICE: APPROVAL AS TO FORM**

*Jodi A. Danneberg* # 229734  
FOR: Tyler M. Renner, Supervising Attorney General

3-28-23  
Date

RESOLUTION NO. 23-90

A RESOLUTION AUTHORIZING AMENDMENT TWO TO THE GRANT AWARD AGREEMENT BETWEEN THE WYOMING OFFICE OF HOMELAND SECURITY AND CITY OF CASPER.

WHEREAS, the City of Casper was awarded a grant from the Wyoming Office of Homeland Security in the amount of One Hundred Nine Thousand Dollars (\$109,000); and,

WHEREAS, the parties desire to enter into Amendment Two to the Grant Award Agreement extending the term of Grant. The grant funds will be used to purchase Regional Response Equipment, to include Escape Packs and a Custom Service Body to be used for confined space entry and to haul equipment to Regional Response calls.

NOW, THEREFORE, BE IT RESOLVED BY THE GOVERNING BODY OF THE CITY OF CASPER, WYOMING: That the Mayor is hereby authorized and directed to execute, and the City Clerk to attest this Resolution and Amendment Two to the above described Agreement.

PASSED, APPROVED, AND ADOPTED on this \_\_\_\_ day of \_\_\_\_\_, 2023.

APPROVED AS TO FORM:

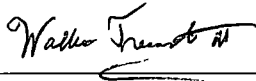
  
\_\_\_\_\_

ATTEST:

CITY OF CASPER, WYOMING  
A Municipal Corporation

\_\_\_\_\_  
Fleur Tremel  
City Clerk

\_\_\_\_\_  
Bruce Knell  
Mayor

April 24, 2023

MEMO TO: J. Carter Napier, City Manager 

FROM: Jacob Black, Fire Chief  
Jason Speiser, Deputy Chief

SUBJECT: Regional Response Grant #21 Amendment Two to Extend Grant Deadline  
Through August 31, 2024

**Meeting Type & Date**

Regular Council Meeting  
May 2, 2023

**Action type**

Resolution

**Recommendation**

That Council, by resolution, approve Amendment Two for Regional Response Grant #21.

**Summary**

Regional Response Grant #21 for \$91,296.00 was originally approved by Council on February 1, 2022 for the purpose of purchasing and shipping of one cargo container trailer with eligible accessories. This project was sent out to bid, but came in over-budget, and therefore was determined to be unfeasible. A grant amendment was approved by the Wyoming Department of Homeland Security to change the scope of the grant to purchase a Ford F550 crew cab chassis to be used as a primary response vehicle to transport crews and equipment to Regional Response calls. Due to production delays, this grant is being extended through August 31, 2024

**Financial Considerations**

None

**Oversight/Project Responsibility**

Jason Speiser; Deputy Chief

**Attachments**

Amendment Two Grant Award Agreement; Grant ID #21-SHSP-RR2-RR-AET1.

APPROVAL AS TO FORM

I have reviewed the attached *Amendment Two to the Grant Award Agreement between Wyoming Office of Homeland Security and City of Casper*, and approve it as to form on behalf of the City of Casper, Wyoming.

Dated: April 20, 2023.

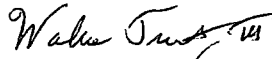
  
\_\_\_\_\_  
Wallace Trembath III  
Deputy City Attorney

**Contract #:** 229733

**Entry Date:** 3/14/2023 3:36:33 PM

WYOMING ATTORNEY  
GENERAL'S OFFICE

4-3-23

Jodi A. Darrough  
APPROVED AS TO FORM

**Department:** Wyoming Office of Homeland Security

**Agency Contact:** Erickson, Darryl (OHS)

**Phone:** 307-777-4917

**Other Agency Contact:**

**Client Comments:**

**Contractor/Vendor Name:** City of Casper

**Contract Title:** 21-SHSP-RR2\_RR-AET1  
Amendment Two

**Contract Type:** Amendment

**Contract Amount:** 91296.0000

**Contract Effective Date:**

**Contract Expiration Date:** 8/31/2024 12:00:00 AM

**Status:** AG Approved as to Form

**RETURN VIA:** ~~Ink Signature~~ ~~Inter-agency Mail~~

**Assigned Attorney:** Jodi Darrough

**AMENDMENT TWO TO THE GRANT AWARD AGREEMENT BETWEEN  
WYOMING OFFICE OF HOMELAND SECURITY  
AND  
CITY OF CASPER**

1. **Parties.** This Amendment is made and entered into by and between the Wyoming Office of Homeland Security (Agency), whose address is: 5500 Bishop Blvd., Cheyenne, WY 82002 the City of Casper (Subrecipient), whose address is: 200 N. David Street, Casper, WY 82601.
2. **Purpose of Amendment.** This Amendment shall constitute the second amendment to the Grant Award Agreement (Agreement) between the Agency and the Subrecipient. The purpose of this Amendment is to extend the term of the Agreement through August 31, 2024.

The original Agreement, dated February 11, 2022, allowed the Subrecipient to expend Grant funds for the purchase and shipping of one cargo container trailer with eligible accessories for a total Agreement amount of ninety-one thousand, two hundred ninety-six dollars and zero cents (\$91,296.00) with an expiration date of August 31, 2023.

Amendment One, dated July 11, 2022 replaced Attachment A, Project Description, with Attachment A-1, Updated Project Description.

3. **Term of the Amendment.** This Amendment shall commence upon the date the last required signature is affixed hereto (Effective Date), and shall remain in full force and effect through the term of the Agreement, as amended, unless terminated at an earlier date pursuant to the provisions of the Agreement, or pursuant to federal or state statute, rule, or regulation.
4. **Amendments.**
  - A. As of the Effective Date of this Amendment Two, the Performance Period referenced in Section 4 of the Agreement shall be amended to read: September 1, 2021 through August 31, 2024.

5. **Amended Responsibilities of the Subrecipient.**

Responsibilities of the Subrecipient have not changed.

6. **Amended Responsibilities of the Agency.**

Responsibilities of the Agency have not changed.

7. **Special Provisions.**

- A. **Same Terms and Conditions.** With the exception of items explicitly delineated in this Amendment, all terms and conditions of the original Agreement, and any previous



amendments, between the Agency and the Subrecipient, including but not limited to sovereign immunity, shall remain unchanged and in full force and effect.

- B. Counterparts.** This Amendment may be executed in counterparts. Each counterpart, when executed and delivered, shall be deemed an original and all counterparts together shall constitute one and the same Amendment. Delivery by the Subrecipient of an originally signed counterpart of this Amendment by facsimile or PDF shall be followed up immediately by delivery of the originally signed counterpart to the Agency.

**8. General Provisions.**

- A. Entirety of Contract.** The original Agreement, consisting of eighteen (18) pages; Attachment A, Project Description, consisting of one (1) page; Amendment One, consisting of three (3) pages; this Amendment Two, consisting of three (3) pages; and Attachment A-1, Updated Project Description, consisting of one (1) page, represent the entire and integrated agreement between the parties and supersede all prior negotiations, representations, and agreements, whether written or oral.

**THE REMAINDER OF THIS PAGE WAS INTENTIONALLY LEFT BLANK.**

9. **Signatures.** The parties to this Amendment, through their duly authorized representatives, have executed this Amendment on the dates set out below, and certify that they have read, understood, and agreed to the terms and conditions of this Amendment.

This Amendment is not binding on either party until approved by A&I Procurement and the Governor of the State of Wyoming or his designee, if required by Wyo. Stat. § 9-2-3204(b)(iv).

**AGENCY: WYOMING OFFICE OF HOMELAND SECURITY**

\_\_\_\_\_  
Lynn Budd, Director

\_\_\_\_\_  
Date

**SUBRECIPIENT: CITY OF CASPER**

\_\_\_\_\_  
Subrecipient Designee Signature

\_\_\_\_\_  
Date

\_\_\_\_\_  
Printed Name and Title of Designee

\_\_\_\_\_  
Date

\_\_\_\_\_  
Attested By:

\_\_\_\_\_  
Date

\_\_\_\_\_  
Attested By:

\_\_\_\_\_  
Date

**ATTORNEY GENERAL'S OFFICE: APPROVAL AS TO FORM**

*Tyler M. Renner* #229733  
FOR: Tyler M. Renner, Supervising Attorney General

*4-3-23*  
\_\_\_\_\_  
Date

RESOLUTION NO. 23-91

A RESOLUTION AUTHORIZING AMENDMENT TWO TO THE GRANT AWARD AGREEMENT BETWEEN THE WYOMING OFFICE OF HOMELAND SECURITY AND CITY OF CASPER.

WHEREAS, the City of Casper was awarded a grant from the Wyoming Office of Homeland Security in the amount of Ninety-One Thousand Two Hundred Ninety-Six Dollars (\$91,296); and,

WHEREAS, the parties desire to enter into Amendment Two to the Grant Award Agreement extending the term of Grant. The grant funds will be used to purchase Regional Response Equipment, to include a Ford F550 Crew Cab Chassis to be used to transport personnel and equipment to Regional Response calls.

NOW, THEREFORE, BE IT RESOLVED BY THE GOVERNING BODY OF THE CITY OF CASPER, WYOMING: That the Mayor is hereby authorized and directed to execute, and the City Clerk to attest this Resolution and Amendment Two to the above described Agreement.

PASSED, APPROVED, AND ADOPTED on this \_\_\_\_\_ day of \_\_\_\_\_, 2023.

APPROVED AS TO FORM:

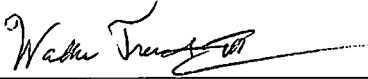
  
\_\_\_\_\_

ATTEST:

\_\_\_\_\_  
Fleur Tremel  
City Clerk

CITY OF CASPER, WYOMING  
A Municipal Corporation

\_\_\_\_\_  
Bruce Knell  
Mayor

April 25, 2023

MEMO TO: J. Carter Napier, City Manager 

FROM: Jacob Black, Fire Chief  
Jason Speiser, Deputy Chief

SUBJECT: USDOT Grant 22-DOT-CAS-HMP3 Through the Office of Homeland Security in the Amount of Sixty-Three Thousand Eighty-Two Dollars \$63,082, With a Local Match Amount of \$15,770.50 (In-Kind)

**Meeting Type & Date**  
Regular Council Meeting  
May 2, 2023

**Action type**  
Resolution

**Recommendation**  
That Council, by resolution, approve USDOT Grant 22-DOT-CAS-HMP3 in the amount of sixty three thousand eighty-two dollars \$63,082, with a local match amount of \$15,770.50 (in-kind) to purchase and install a hazardous material confined space container training prop.

**Summary**  
USDOT Grant 22-DOT-CAS-HMP3 in the amount of sixty-three thousand eighty-two dollars \$63,082, with a local match amount of \$15,770.50 (in-kind) will be used to purchase and install a hazardous material confined space container training prop to be installed at the Regional Fire Training Facility on Metro Road. This prop will be use by local and regional fire departments to train on confined space rescue evolutions. In kind services will assist with site prep and installing the prop.

**Financial Considerations**  
None.

**Oversight/Project Responsibility**  
Jason Speiser; Deputy Chief

**Attachments**  
Grant Award Agreement USDOT Grant 22-DOT-CAS-HMP3

APPROVAL AS TO FORM

I have reviewed the attached *Grant Award Agreement between Wyoming Office of Homeland Security and City of Casper*, and approve it as to form on behalf of the City of Casper, Wyoming.

Dated: April 20, 2023.

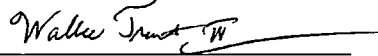

Wallace Trembath III  
Deputy City Attorney

**Attachment A: Project Description**

**City of Casper**

**Project ID: 22-DOT-CAS-HMP3**

**Award Amount: \$63,082.00**

**Local Match Amount: \$15,770.50 (in-kind)**

The following submitted project(s) have been approved for the Federal Fiscal Year 2022 U.S. Department of Transportation, Hazardous Materials Emergency Preparedness (HMEP) Grant. Only expenditures within the scope of the below projects will be reimbursed by the Wyoming Office of Homeland Security. Any changes to the scope of work must be approved through the Wyoming Office of Homeland Security prior to implementation.

| Description                                                                                                                                                             | Amount                                   |
|-------------------------------------------------------------------------------------------------------------------------------------------------------------------------|------------------------------------------|
| <p align="center">Eligible Expenses as follows:</p> <ul style="list-style-type: none"><li data-bbox="370 840 922 874">• HMCS Shipping Container Training Prop</li></ul> | <p align="center"><b>\$63,082.00</b></p> |

For questions regarding individual project allowability, the scope of an approved project, or the 2022 HMEP, please contact:

Nick Wardle  
Grant Program Manager  
Wyoming Office of Homeland Security  
307-777-4951

Ashley Paulsrud  
Grants/Finance Section Chief  
Wyoming Office of Homeland Security  
307-777-4907

**Contract #:** 230064

**Entry Date:** 3/28/2023 12:48:54 PM

**Department:** Wyoming Office of Homeland Security

WYOMING ATTORNEY  
GENERAL'S OFFICE

4-7-23

Jodi A. Darrough  
APPROVED AS TO FORM

**Agency Contact:** Wardle, Nick

**Phone:** 307-777-4951

**Other Agency Contact:** Ashley Paulsrud 307-  
777-4907

**Client Comments:**

**Contractor/Vendor Name:** City of Casper

**Contract Title:** 22-DOT-CAS-HMP3 Casper  
HMEP Grant

**Contract Type:** Grant Agreement - Federal

**Contract Amount:** 63082.0000

**Contract Effective Date:**

**Contract Expiration Date:** 9/30/2025 12:00:00 AM

**Status:** AG Approved as to Form

**RETURN VIA:** ~~Ink Signature - Inter-agency Mail~~

**Assigned Attorney:** Jodi Darrough

**GRANT AWARD AGREEMENT BETWEEN  
WYOMING OFFICE OF HOMELAND SECURITY  
AND  
CITY OF CASPER**

**Subrecipient Grant Award Agreement for U.S. Department of Transportation, Hazardous Materials Emergency Planning (HMEP) Grant Fiscal Year 2022 through Fiscal Year 2024.**

|                               |                                                   |
|-------------------------------|---------------------------------------------------|
| <b>Subrecipient:</b>          | <b>City of Casper</b>                             |
| <b>UEI #:</b>                 | <b>X7BTN16ZQSY9</b>                               |
| <b>Federal Award Amount:</b>  | <b>\$63,082.00</b>                                |
| <b>Local Match Amount:</b>    | <b>\$15,770.50</b>                                |
| <b>Period of Performance:</b> | <b>October 1, 2022 through September 30, 2025</b> |
| <b>CFDA #:</b>                | <b>20.703</b>                                     |
| <b>DOT Grant Award #:</b>     | <b>693JK32240052HMEP</b>                          |
| <b>Federal Award Date:</b>    | <b>September 29, 2022</b>                         |
| <b>Project ID:</b>            | <b>22-DOT-CAS-HMP3</b>                            |

- 1. Parties.** The parties to this Agreement are Wyoming Office of Homeland Security (Agency), whose address is: 5500 Bishop Blvd., Cheyenne, WY 82002, and City of Casper (Subrecipient), whose address is: 200 N David St., Casper, WY 82601.
- 2. Purpose of Agreement.** The purpose of this Grant Award Agreement (Agreement) is to set forth the terms and conditions by which the Subrecipient shall support the development, improvement, and implementation of hazardous materials emergency plans under the Federal Emergency Planning Community Right-to-Know Act (EPCRA). Specific activities that will improve planning have been identified by Congress to include conducting commodity flow assessments, hazards analysis, drills and exercises, and enhancing emergency plans. Funding may also be used for training public sector employees to respond safely and efficiently to accidents and incidents, including those involving transportation of hazardous materials. Funds may not be used to purchase equipment. This is a Non-Construction Grant and the grant funds do not lose their federal identity. This award is not for the purposes of Research & Development (R&D) as defined in 2 C.F.R. 200.87.
- 3. Funding Authority.** The funds Agency will distribute to Subrecipient are drawn from grant funds distributed to the State of Wyoming by the FY 2022-FY2024 Department of Transportation Hazardous Materials Emergency Planning Grant, as authorized by 1) Federal Hazardous Materials Transportation Law, 49 U.S.C. § 5101 et seq., and 2) 49 U.S.C. § 5116, 3) 49 CFR Part 110, 4) 2 CFR Part 200, and 5) the Fixing America's Surface Transportation (FAST) Act Public Law No. 114-94.
- 4. Term of Agreement.** This Agreement is effective when all parties have executed it (Effective Date). The Period of Performance of the Agreement is from October 1, 2022 through September 30, 2025. All services shall be completed during the Period of Performance.



This Agreement may be extended by agreement of both parties in writing and subject to the required approvals. There is no right or expectation of extension and any extension will be determined at the discretion of the Agency.

**5. Payment.**

- A.** The Agency agrees to pay the Subrecipient for the services described in Attachment A, Project Description, which is attached to and incorporated into this Agreement by this reference. Total payment under this Agreement shall not exceed sixty-three thousand, eighty-two dollars and zero cents (\$63,082.00). Payment shall be made when services are completed, and within forty-five (45) days after submission of invoice pursuant to Wyo. Stat. § 16-6-602. Subrecipient shall submit all invoices in sufficient detail to ensure that payments may be made in conformance with this Agreement. Subrecipient shall submit all invoices within forty-five (45) days after the term of this Agreement.
- B.** No payment shall be made for work performed outside the Period of Performance of this Agreement. Should the Subrecipient fail to perform in a manner consistent with the terms and conditions set forth in this Agreement, payment under this Agreement may be withheld until such time as the Subrecipient performs its duties and responsibilities to the satisfaction of Agency.
- C. Travel.** The payment of travel expenses shall be allowed as set forth below. Subrecipient is expected to procure the most cost efficient travel arrangements.
- (i) Air Travel. The Agency agrees to reimburse the Subrecipient's air travel expenses related to the performance of this Agreement. Air travel shall be reimbursed based on actual costs, supported by a copy of the original receipt with the invoice. Subrecipient must select the lowest airfare (fares available in the market at the time of booking, preferably well in advance of trip to attain the lowest possible airfare). Subrecipient shall book economy class fares for all domestic travel. First class bookings are not reimbursable.
- (ii) Personal Vehicle. The Agency agrees to reimburse the Subrecipient's approved use of personal vehicle. Mileage shall be reimbursed at the current State rate per mile based on standard map mileage. Fuel will not be reimbursed.
- (iii) Car Rental. The Agency agrees to reimburse the Subrecipient's car rental expenses related to the performance of this Agreement. Car rental expenses shall be reimbursed at actual costs, supported by a copy of the original receipt with the invoice. Subrecipient must select the lowest rental rates for an appropriate vehicle.
- D. Lodging.** The Agency agrees to reimburse Subrecipient's approved lodging expenses related to the performance of this Agreement. Lodging expenses shall be reimbursed at actual costs, supported by a copy of the original receipt with the invoice. The Subrecipient shall only invoice the Agency for the basic room rate,

taxes, and lodging fees. The Agency is not responsible for incidental or miscellaneous expenses charged to the room. Incidental and miscellaneous expenses for which the Agency shall not be responsible include charges such as alcohol, internet, telephone charges, mini-bar, and movies.

- E. **Meals.** The Agency agrees to reimburse Subrecipient's meal expenses related to the performance of this Agreement. Meal expenses shall be reimbursed based on actual costs, supported by a copy of the original receipt with the invoice.

6. **Responsibilities of Subrecipient.** The Subrecipient agrees to:

- A. Complete the project described in Attachment A, Project Description.
- B. Comply with terms and conditions as described in Attachment B, Agreement Articles, which is attached to and incorporated into this Agreement by this reference.
- C. Comply with the Fiscal Year 2022 Hazardous Materials Emergency Preparedness (HMEP) Grant Notice of Funding Opportunity (NOFO) to implement this Agreement. All use of funds under this Agreement will be in accordance with the HMEP NOFO.
- D. Keep the Agency up-to-date as to the name of the person acting as the primary contact person for this Agreement using Attachment C, Point of Contact Information Form provided by the Agency, which is incorporated into this Agreement by this reference, including any change of contact person, address, email, or telephone information. Subrecipient's primary contact shall cooperate with any assessments, national evaluation efforts, or information or data collect requests, including, but not limited to, the provision of any information required for the assessment or evaluation of any activities within this Agreement.
- E. Subrecipient shall use its own documented procurement procedures that reflect applicable state, local, territorial, and tribal laws and regulations, provided that the procurements conform to applicable federal law and the standards identified in 2 C.F.R. Part 200. All procurement activity must be conducted in accordance with Federal Procurement Standards 2 C.F.R. Part 200.317-200.326
- F. Subrecipient shall provide local match totaling fifteen thousand, seven hundred seventy dollars and fifty cents (\$15,770.50).

7. **Responsibilities of Agency.** The Agency agrees to:

- A. Pay Subrecipient in accordance with Section 5 above.
- B. Be available to provide necessary and feasible technical advice as requested by Subrecipient.

- C. Notify Subrecipient of information and updates received from DOT or other federal agencies, which may affect or otherwise restrict the availability of funds awarded to Subrecipient herein.

8. **Special Provisions.**

- A. **Assumption of Risk.** The Subrecipient shall assume the risk of any loss of state or federal funding, either administrative or program dollars, due to the Subrecipient's failure to comply with state or federal requirements. The Agency shall notify the Subrecipient of any state or federal determination of noncompliance.
- B. **Environmental Policy Acts.** Subrecipient agrees all activities under this Agreement will comply with the Clean Air Act, the Clean Water Act, the National Environmental Policy Act, and other related provisions of federal environmental protection laws, rules or regulations.
- C. **Human Trafficking.** As required by 22 U.S.C. § 7104(g) and 2 CFR Part 175, this Agreement may be terminated without penalty if a private entity that receives funds under this Agreement:
  - (i) Engages in severe forms of trafficking in persons during the period of time that the award is in effect;
  - (ii) Procures a commercial sex act during the period of time that the award is in effect; or
  - (iii) Uses forced labor in the performance of the award or subawards under the award.
- D. **Kickbacks.** Subrecipient certifies and warrants that no gratuities, kickbacks, or contingency fees were paid in connection with this Agreement, nor were any fees, commissions, gifts, or other considerations made contingent upon the award of this Agreement. If Subrecipient breaches or violates this warranty, Agency may, at its discretion, terminate this Agreement without liability to Agency, or deduct from the agreed upon price or consideration, or otherwise recover, the full amount of any commission, percentage, brokerage, or contingency fee.
- E. **Limitations on Lobbying Activities.** By signing this Agreement, Subrecipient certifies and agrees that, in accordance with P.L. 101-121, payments made from a federal grant shall not be utilized by Subrecipient or its sub-subrecipients in connection with lobbying member(s) of Congress, or any federal agency in connection with the award of a federal grant, Agreement, cooperative agreement, or loan.
- F. **Monitoring Activities.** Agency shall have the right to monitor all activities related to this Agreement that are performed by Subrecipient or its sub-subrecipients. This

shall include, but not be limited to, the right to make site inspections at any time and with reasonable notice; to bring experts and consultants on site to examine or evaluate completed work or work in progress; to examine the books, ledgers, documents, papers, and records pertinent to this Agreement; and to observe personnel in every phase of performance of Agreement related work.

- G. Nondiscrimination.** The Subrecipient shall comply with the Civil Rights Act of 1964, the Wyoming Fair Employment Practices Act (Wyo. Stat. § 27-9-105, *et seq.*), the Americans with Disabilities Act (ADA), 42 U.S.C. § 12101, *et seq.*, and the Age Discrimination Act of 1975 and any properly promulgated rules and regulations thereto and shall not discriminate against any individual on the grounds of age, sex, color, race, religion, national origin, or disability in connection with the performance under this Agreement.
- H. No Finder's Fees:** No finder's fee, employment agency fee, or other such fee related to the procurement of this Agreement, shall be paid by either party.
- I. Publicity.** Any publicity given to the projects, programs, or services provided herein, including, but not limited to, notices, information, pamphlets, press releases, research, reports, signs, and similar public notices in whatever form, prepared by or for the Subrecipient and related to the services and work to be performed under this Agreement, shall identify the Agency as the sponsoring agency and shall not be released without prior written approval of Agency.
- J. Suspension and Debarment.** By signing this Agreement, Subrecipient certifies that neither it nor its principals/agents are presently debarred, suspended, proposed for debarment, declared ineligible, or voluntarily excluded from participation in this transaction or from receiving federal financial or nonfinancial assistance, nor are any of the participants involved in the execution of this Agreement suspended, debarred, or voluntarily excluded by any federal department or agency in accordance with Executive Order 12549 (Debarment and Suspension), 44 CFR Part 17, or 2 CFR Part 180, or are on the debarred, or otherwise ineligible, vendors lists maintained by the federal government. Further, Subrecipient agrees to notify Agency by certified mail should it or any of its principals/agents become ineligible for payment, debarred, suspended, or voluntarily excluded from receiving federal funds during the term of this Agreement.
- K. Administration of Federal Funds.** Subrecipient agrees its use of the funds awarded herein is subject to the Uniform Administrative Requirements of 2 C.F.R. Part 200, *et seq.*; any additional requirements set forth by the federal funding agency; all applicable regulations published in the Code of Federal Regulations; and other program guidance as provided to it by Agency.
- L. Copyright License and Patent Rights.** Subrecipient acknowledges that federal grantor, the State of Wyoming, and Agency reserve a royalty-free, nonexclusive, unlimited, and irrevocable license to reproduce, publish, or otherwise use, and to authorize others to use, for federal and state government purposes: (1) the copyright in any work developed under this Agreement; and (2) any rights of copyright to

which Subrecipient purchases ownership using funds awarded under this Agreement. Subrecipient must consult with Agency regarding any patent rights that arise from, or are purchased with, funds awarded under this Agreement.

- M. Federal Audit Requirements.** Subrecipient agrees that if it expends an aggregate amount of seven hundred fifty thousand dollars (\$750,000.00) or more in federal funds during its fiscal year, it must undergo an organization-wide financial and compliance single audit. Subrecipient agrees to comply with the audit requirements of the U.S. General Accounting Office Government Auditing Standards and Audit Requirements of 2 C.F.R. Part 200, Subpart F. If findings are made which cover any part of this Agreement, Subrecipient shall provide one (1) copy of the audit report to Agency and require the release of the audit report by its auditor be held until adjusting entries are disclosed and made to Agency's records.
- N. Non-Supplanting Certification.** Subrecipient hereby affirms that federal grant funds shall be used to supplement existing funds, and shall not replace (supplant) funds that have been appropriated for the same purpose. Subrecipient should be able to document that any reduction in non-federal resources occurred for reasons other than the receipt or expected receipt of federal funds under this Agreement.
- O. Program Income.** Subrecipient shall not deposit grant funds in an interest bearing account without prior approval of Agency. Any income attributable to the grant funds distributed under this Agreement must be used to increase the scope of the program or returned to Agency.

9. **General Provisions.**

- A. Amendments.** Any changes, modifications, revisions, or amendments to this Agreement which are mutually agreed upon by the parties to this Agreement shall be incorporated by written instrument, executed by all parties to this Agreement.
- B. Applicable Law, Rules of Construction, and Venue.** The construction, interpretation, and enforcement of this Agreement shall be governed by the laws of the State of Wyoming, without regard to conflicts of law principles. The terms "hereof," "hereunder," "herein," and words of similar import, are intended to refer to this Agreement as a whole and not to any particular provision or part. The Courts of the State of Wyoming shall have jurisdiction over this Agreement and the parties. The venue shall be the First Judicial District, Laramie County, Wyoming.
- C. Assignment Prohibited and Agreement Shall Not be Used as Collateral.** Neither party shall assign or otherwise transfer any of the rights or delegate any of the duties set out in this Agreement without the prior written consent of the other party. The Subrecipient shall not use this Agreement, or any portion thereof, for collateral for any financial obligation without the prior written permission of the Agency.
- D. Audit and Access to Records.** The Agency and its representatives shall have access to any books, documents, papers, electronic data, and records of the

Subrecipient which are pertinent to this Agreement. The Subrecipient shall immediately, upon receiving written instruction from the Agency, provide to any independent auditor or accountant all books, documents, papers, electronic data, and records of the Subrecipient which are pertinent to this Agreement. The Subrecipient shall cooperate fully with any such independent auditor or accountant during the entire course of any audit authorized by the Agency.

- E. Availability of Funds.** Each payment obligation of the Agency is conditioned upon the availability of government funds which are appropriated or allocated for the payment of this obligation and which may be limited for any reason including, but not limited to, congressional, legislative, gubernatorial, or administrative action. If funds are not allocated and available for continued performance of the Agreement, the Agreement may be terminated by the Agency at the end of the period for which the funds are available. The Agency shall notify the Subrecipient at the earliest possible time of the services which will or may be affected by a shortage of funds. No penalty shall accrue to the Agency in the event this provision is exercised, and the Agency shall not be obligated or liable for any future payments due or for any damages as a result of termination under this section.
- F. Award of Related Agreements.** The Agency may award supplemental or successor Agreements for work related to this Agreement or may award Agreements to other subrecipients for work related to this Agreement. The Subrecipient shall cooperate fully with other Subrecipients and the Agency in all such cases.
- G. Compliance with Laws.** The Subrecipient shall keep informed of and comply with all applicable federal, state, and local laws and regulations, and all federal grant requirements and executive orders in the performance of this Agreement.
- H. Confidentiality of Information.** Except when disclosure is required by the Wyoming Public Records Act or court order, all documents, data compilations, reports, computer programs, photographs, data, and other work provided to or produced by the Subrecipient in the performance of this Agreement shall be kept confidential by the Subrecipient unless written permission is granted by the Agency for its release. If and when Subrecipient receives a request for information subject to this Agreement, Subrecipient shall notify Agency within ten (10) days of such request and shall not release such information to a third party unless directed to do so by Agency.
- I. Entirety of Agreement.** This Agreement, consisting of eleven (11) pages; Attachment A, Project Description, consisting of one (1) page; Attachment B, Agreement Articles, consisting of fifteen (15) pages; and Attachment C, Point of Contact Information Form, consisting of one (1) page, represent the entire and integrated Agreement between the parties and supersede all prior negotiations, representations, and agreements, whether written or oral. In the event of a conflict or inconsistency between the language of this Agreement and the language of any attachment or document incorporated by reference, the language of this Agreement shall control.

- J. Ethics.** Subrecipient shall keep informed of and comply with the Wyoming Ethics and Disclosure Act (Wyo. Stat. § 9-13-101, *et seq.*) and any and all ethical standards governing Subrecipient's profession.
- K. Extensions.** Nothing in this Agreement shall be interpreted or deemed to create an expectation that this Agreement will be extended beyond the term described herein. Any extension of this Agreement shall be initiated by the Agency and shall be accomplished through a written amendment between the parties entered into before the expiration of the original Agreement or any valid amendment thereto, and shall be effective only after it is reduced to writing and executed by all parties to the Agreement.
- L. Force Majeure.** Neither party shall be liable for failure to perform under this Agreement if such failure to perform arises out of causes beyond the control and without the fault or negligence of the nonperforming party. Such causes may include, but are not limited to, acts of God or the public enemy, fires, floods, epidemics, quarantine restrictions, freight embargoes, and unusually severe weather. This provision shall become effective only if the party failing to perform immediately notifies the other party of the extent and nature of the problem, limits delay in performance to that required by the event, and takes all reasonable steps to minimize delays.
- M. Indemnification.** Each party to this Agreement shall assume the risk of any liability arising from its own conduct. Neither party agrees to insure, defend, or indemnify the other.
- N. Independent Contractor.** The Subrecipient shall function as an independent contractor for the purposes of this Agreement and shall not be considered an employee of the State of Wyoming for any purpose. Consistent with the express terms of this Agreement, the Subrecipient shall be free from control or direction over the details of the performance of services under this Agreement. The Subrecipient shall assume sole responsibility for any debts or liabilities that may be incurred by the Subrecipient in fulfilling the terms of this Agreement and shall be solely responsible for the payment of all federal, state, and local taxes which may accrue because of this Agreement. Nothing in this Agreement shall be interpreted as authorizing the Subrecipient or its agents or employees to act as an agent or representative for or on behalf of the State of Wyoming or the Agency or to incur any obligation of any kind on behalf of the State of Wyoming or the Agency. The Subrecipient agrees that no health or hospitalization benefits, workers' compensation, unemployment insurance, or similar benefits available to State of Wyoming employees will inure to the benefit of the Subrecipient or the Subrecipient's agents or employees as a result of this Agreement.
- O. Notices.** All notices arising out of, or from, the provisions of this Agreement shall be in writing either by regular mail or delivery in person at the addresses provided under this Agreement.

**Contact for the Agency:**

Nick Wardle  
Radiological and Hazardous Materials Specialist  
5500 Bishop Boulevard  
Cheyenne, Wyoming 82009  
307-777-4951  
[nick.wardle@wyo.gov](mailto:nick.wardle@wyo.gov)

*With a copy to:*

Lynn Budd (Awarding Official)  
Director, Wyoming Office of Homeland Security  
5500 Bishop Boulevard  
Cheyenne, Wyoming 82009  
307-777-8511  
[Lynn.budd@wyo.gov](mailto:Lynn.budd@wyo.gov)

- P. Ownership and Return of Documents and Information.** Agency is the official custodian and owns all documents, data compilations, reports, computer programs, photographs, data, and other work provided to or produced by the Subrecipient in the performance of this Agreement. Upon termination of services, for any reason, Subrecipient agrees to return all such original and derivative information and documents to the Agency in a useable format. In the case of electronic transmission, such transmission shall be secured. The return of information by any other means shall be by a parcel service that utilizes tracking numbers.
- Q. Patent or Copyright Protection.** The Subrecipient recognizes that certain proprietary matters or techniques may be subject to patent, trademark, copyright, license, or other similar restrictions, and warrants that no work performed by the Subrecipient or its sub-subrecipients will violate any such restriction. The Subrecipient shall defend and indemnify the Agency for any infringement or alleged infringement of such patent, trademark, copyright, license, or other restrictions.
- R. Prior Approval.** This Agreement shall not be binding upon either party, no services shall be performed, and the Wyoming State Auditor shall not draw warrants for payment, until this Agreement has been fully executed, approved as to form by the Office of the Attorney General, filed with and approved by A&I Procurement, and approved by the Governor of the State of Wyoming, or his designee, if required by Wyo. Stat. § 9-2-3204(b)(iv).
- S. Severability.** Should any portion of this Agreement be judicially determined to be illegal or unenforceable, the remainder of the Agreement shall continue in full force and effect, and the parties may renegotiate the terms affected by the severance.
- T. Sovereign Immunity and Limitations.** Pursuant to Wyo. Stat. § 1-39-104(a), the State of Wyoming and Agency expressly reserve sovereign immunity by entering into this Agreement and the Subrecipient expressly reserves governmental immunity. Each of them specifically retains all immunities and defenses available



to them as sovereigns or governmental entities pursuant to Wyo. Stat. § 1-39-101, *et seq.*, and all other applicable law. The parties acknowledge that the State of Wyoming has sovereign immunity and only the Wyoming Legislature has the power to waive sovereign immunity. Designations of venue, choice of law, enforcement actions, and similar provisions shall not be construed as a waiver of sovereign immunity. The parties agree that any ambiguity in this Agreement shall not be strictly construed, either against or for either party, except that any ambiguity as to immunity shall be construed in favor of immunity.

- U. **Taxes.** The Subrecipient shall pay all taxes and other such amounts required by federal, state, and local law, including, but not limited to, federal and social security taxes, workers' compensation, unemployment insurance, and sales taxes.
- V. **Termination of Agreement.** This Agreement may be terminated, without cause, by the Agency upon thirty (30) days written notice. This Agreement may be terminated by the Agency immediately for cause if the Subrecipient fails to perform in accordance with the terms of this Agreement.
- W. **Third-Party Beneficiary Rights.** The parties do not intend to create in any other individual or entity the status of third-party beneficiary, and this Agreement shall not be construed so as to create such status. The rights, duties, and obligations contained in this Agreement shall operate only between the parties to this Agreement and shall inure solely to the benefit of the parties to this Agreement. The provisions of this Agreement are intended only to assist the parties in determining and performing their obligations under this Agreement.
- X. **Time is of the Essence.** Time is of the essence in all provisions of this Agreement.
- Y. **Titles Not Controlling.** Titles of sections and subsections are for reference only and shall not be used to construe the language in this Agreement.
- Z. **Waiver.** The waiver of any breach of any term or condition in this Agreement shall not be deemed a waiver of any prior or subsequent breach. Failure to object to a breach shall not constitute a waiver.
- AA. **Counterparts.** This Agreement may be executed in counterparts. Each counterpart, when executed and delivered, shall be deemed an original and all counterparts together shall constitute one and the same Agreement. Delivery by the Subrecipient of an originally signed counterpart of this Agreement by facsimile or PDF shall be followed up immediately by delivery of the originally signed counterpart to the Agency.

**THE REMAINDER OF THIS PAGE WAS INTENTIONALLY LEFT BLANK.**

10. **Signatures.** The parties to this Agreement, either personally or through their duly authorized representatives, have executed this Agreement on the dates set out below, and certify that they have read, understood, and agreed to the terms and conditions of this Agreement.

The Effective Date of this Agreement is the date of the signature last affixed to this page.

**AGENCY:**

Wyoming Office of Homeland Security

\_\_\_\_\_  
Lynn Budd, Director

\_\_\_\_\_  
Date

**SUBRECIPIENT:**

City of Casper

\_\_\_\_\_  
Subrecipient Designee Signature

\_\_\_\_\_  
Date

\_\_\_\_\_  
Printed Name and Title of Designee

**ATTORNEY GENERAL'S OFFICE: APPROVAL AS TO FORM**

*Jodi A. Darrough* #2800064  
\_\_\_\_\_  
Jodi A. Darrough, Senior Assistant Attorney General

*4-7-23*  
\_\_\_\_\_  
Date

**Attachment B: Agreement Articles**

**Department of Transportation  
Pipeline and Hazardous Materials Safety Administration (PHMSA)  
Hazardous Materials Grants**

**Grant and Cooperative Agreement  
Terms and Conditions**

**Table of Contents**

1. **Definitions** ..... 2  
2. **Recipient Responsibilities** ..... 2  
3. **Compliance with Award Terms and Conditions**..... 2  
4. **Order of Precedence**..... 2  
5. **Uniform Administrative Requirements, Cost Principles, and Audit Requirements for Federal Awards (2 CFR 200)** ..... 3  
6. **Restrictions on Use of Funds for Lobbying, Support of Litigation, or Direct Advocacy** 3  
7. **Nondiscrimination** ..... 3  
8. **Government-wide Debarment and Suspension (Non-procurement)**..... 3  
9. **Drug-Free Workplace** ..... 4  
10. **eInvoicing (PHMSA June 2018)** ..... 4  
11. **Payments** ..... 5  
12. **Advance Payments**..... 6  
13. **Advance Payment Process**..... 7  
14. **Adherence to Original Project Objectives and Budget Estimates** ..... 7  
15. **Prior Approvals** ..... 8  
16. **Contracting with Small Businesses, Small Minority-Disadvantaged Businesses, and Small Businesses which are Women-Owned, Veteran-Owned, Disabled Veteran-Owned or located in HubZone Areas** ..... 8  
17. **Seat Belt Use Policies and Programs**..... 9  
18. **Ban on Text Messaging While Driving** ..... 9  
19. **Rights in Technical Data** ..... 10  
20. **Notice of News Releases, Public Announcements, and Presentations** ..... 10  
21. **Violation of Award Terms** ..... 10  
22. **Reporting Fraud, Waste, or Abuse** ..... 10  
23. **Reporting Grantee Executive Compensation/First Tier Sub-Awards (PHMSA Oct, 2010)** ..... 10  
24. **811, Call Before You Dig Program (PHMSA June 2014)** ..... 13  
25. **Access to Electronic and Information Technology (PHMSA DEC 2013)**..... 13  
26. **Combating Trafficking in Persons (PHMSA JULY 2016)**..... 13  
27. **Prohibition on Awarding to Entities that Require Certain Internal Confidentiality Agreements (PHMSA FEB 2015)**..... 14  
28. **Copyrights**..... 15  
29. **Reporting**..... 15

## 1. Definitions

- a) **Recipient** – A non-Federal entity that receives a Federal award directly from a Federal awarding agency to carry out an activity under a Federal program. The term “recipient” does not include subrecipients.
- b) **Program Authorizing Official (PAO)** – The PAO is the delegated authority to execute the grant agreement. Should any changes to the scope, budget, schedule, or any other terms become necessary, the PAO in coordination with the AO has the authority to amend the award agreement.
- c) **Agreement Officer (AO)** – The AO has the authority to obligate the Government to the expenditures of Federal funds under this award.
- d) **Grant Specialist (GS)** – The GS is responsible for the daily administration of the award. The GS is NOT AUTHORIZED to change the scope, budget, specifications, and terms and conditions as stated in the award, to make any commitments that otherwise obligates the Government or authorize changes which affect the award budget, delivery schedule, period of performance, or other terms and conditions.
- e) **Recipient Authorized Grantee Official** – The individual with the Recipient organization who has authority to legally and financially bind the organization. It is the Recipient’s responsibility to follow their agency’s policies and procedures for ensuring that authorized officials are up to date, sign the grant agreement, and endorse any prior approval actions.
- f) **Recipient Project Director** – The individual designated by the recipient who is responsible for the technical direction of the program or project.

## 2. Recipient Responsibilities

In accepting a PHMSA financial assistance award (grant or cooperative agreement), the Recipient assumes legal, financial, administrative, and programmatic responsibility for administering the award in accordance with the laws, rules, regulations, and Executive Orders governing grants and cooperative agreements, and these Award Terms and Conditions, including responsibility for complying with any provisions included in the award.

## 3. Compliance with Award Terms and Conditions

Submission of an application constitutes the Recipient’s agreement to comply with and spend funds consistent with all the terms and conditions of this award. If PHMSA determines that noncompliance by the Recipient cannot be remedied by imposing additional conditions, PHMSA may take one or more of the following actions, as appropriate in the circumstances:

- a) Temporarily withhold cash payments pending correction of the deficiency by the Recipient.
- b) Disallow all, or part of, the cost of the activity or action not in compliance.
- c) Wholly or partly suspend or terminate the Federal award.
- d) Initiate suspension or debarment proceedings as authorized under 2 CFR part 180.
- e) Withhold further Federal awards for the project or program.
- f) Take other remedies that may be legally available.

## 4. Order of Precedence

Any inconsistency or conflict in the terms and conditions specified in this award will be resolved according to the following order of precedence:

- a) The Federal statute authorizing this award or any other Federal statutes, laws, regulations or directives directly affecting performance of this award.
- b) Terms and Conditions of this award.

**5. Uniform Administrative Requirements, Cost Principles, and Audit Requirements for Federal Awards (2 CFR 200)**

The recipient (and any subrecipients) must comply with these requirements including the cost principles which apply to the recipient, and the audit requirements the recipient must follow. A recipient which expends \$750,000 or more of federal funds, in the recipient's fiscal year, must have an audit conducted.

**2 CFR 200** is incorporated by reference into this award

**6. Restrictions on Use of Funds for Lobbying, Support of Litigation, or Direct Advocacy** The Recipient and its contractors may not use grant funds for lobbying in direct support of litigation, or in direct advocacy for, or against, a pipeline construction or expansion project.

The Recipient and its contractors may not conduct political lobbying, as defined in the statutes, regulations, and 2 CFR 200.450– “Lobbying,” within the Federally-supported project. The Recipient and its contractors may not use Federal funds for lobbying specifically to obtain grants and cooperative agreements. The Recipient and its contractors must comply with 49 CFR 20, U.S. Department of Transportation “New Restrictions on Lobbying.”

**49 CFR 20** is incorporated by reference into this award.

**7. Nondiscrimination**

The Recipient must comply with Title VI of the Civil Right Act of 1964, which provides that no person in the United States shall, on the grounds of race, color, or national origin, be excluded from participation in, be denied benefits of, be subject to discrimination under any program or activity receiving Federal financial assistance. The Recipient must comply with 49 CFR 21, “Nondiscrimination in Federally-Assisted Programs of the Department of Transportation— Effectuation of Title VI of the Civil Rights Act of 1964”

**49 CFR 21** is incorporated by reference into this award.

In an effort to ensure that all Recipients of PHMSA funds are aware of their responsibilities under the various civil rights laws and regulations, the PHMSA Office of Civil Rights has developed an information tool and training. These documents are found on the PHMSA website at <https://www.phmsa.dot.gov/about-phmsa/civil-rights/grant-recipient-information>. If you should have any questions concerning your responsibilities under the External Civil Rights Program, please contact Rosanne Goodwill, Civil Rights Director, at 202-366-9638 or by e-mail at [rosanne.goodwill@dot.gov](mailto:rosanne.goodwill@dot.gov).

**8. Government-wide Debarment and Suspension (Non-procurement)**

The Recipient must review the “list of parties excluded from federal procurement or non-procurement programs” located on the System for Award Management (SAM) website before entering into a sub-award. <https://www.sam.gov> No sub-award may be issued to an entity or person identified in the “list of parties excluded from federal procurement or non-procurement programs.”

**2 CFR 1200** “Non-procurement Suspension and Debarment” is incorporated by reference into this award.

The Recipient must inform the PAO if the recipient suspends or debars a sub-awardee.

**9. Drug-Free Workplace**

The Recipient must comply with the provisions of Public Law 100-690, Title V, Subtitle D, “Drug-Free Workplace Act of 1988,” which require the Recipient to take steps to provide a drug-free workplace. The Recipient must comply with **49 CFR 32**, “Government-wide Requirements for Drug Free Workplace (Financial Assistance)” which is incorporated by reference into this award.

**10. eInvoicing (PHMSA June 2018)**

Recipients of PHMSA grants and cooperative agreements must use the DOT Delphi eInvoicing System.

**a) Recipients’ Requirements:**

Recipients must:

- i. have internet access to register and submit payment requests through the Delphi eInvoicing system.
- ii. submit payment requests electronically, and receive payment electronically.

**b) System User Requirements:**

- i. Contact the assigned grant specialist directly to sign up for the system. PHMSA will provide the recipient’s name and email address to the DOT Financial Management Office. The DOT Financial Management Office will then invite the recipient to sign up for the system.
- ii. DOT will send the recipient a User Account Application form to verify identity. The recipient must complete the form, and present it to a Notary Public for verification. The recipient will return the notarized form as follows:

**Via U.S. Postal Service (certified):**

DOT Enterprise Services Center FAA  
Accounts Payable, AMZ-100 PO Box  
25710  
Oklahoma City, OK 73125

**Via FedEx or UPS:**

DOT Enterprise Services Center  
MMAC-FAA/ESC/AMZ-150  
6500 S. MacArthur Blvd. Oklahoma  
City, OK 73169

**Note:** Additional information, including training materials, and helpdesk support can be found on the DOT Delphi eInvoicing website (<http://www.transportation.gov/cfo/delphi-einvoicing-system.html>)

**c) Waivers**

DOT Financial Management officials may, on a case by case basis, waive the requirement to register, and use, the electronic payment system. Waiver request forms can be obtained on the DOT eInvoicing website (<http://www.transportation.gov/cfo/delphi-einvoicing->

Attachment B to the Grant Agreement between Wyoming Office of Homeland Security  
and City of Casper

system.html) or by contacting the PHMSA Agreement Officer. Recipients must explain why they are unable to use or access the internet to submit payment requests.

## 11. Payments

Reimbursement payments will be made after the electronic receipt via the DOTeInvoicing System of "Request for Advance or Reimbursement" (Standard Form SF-270).

- a) Method of payment
  - i) The Government will make all payments under this agreement by electronic funds transfer (EFT), except as provided by paragraph (a)(ii) of this clause. As used in this clause, the term "EFT" refers to the funds transfer and may also include the payment information transfer.
  - ii) If the Government is unable to release one or more payments by EFT, the Recipient agrees either to –
    - i) Accept payment by check or some other mutually agreeable method of payment; or
    - ii) Request the Government to extend the payment due date until such time as the Government can make payment by EFT (but see paragraph d. of this clause).
- b) Recipient's EFT information. The Government will make payment to the Recipient using the EFT information contained in the System for Award Management (SAM) database. If the EFT information changes, the Recipient is responsible for providing the updated information into the System for Award Management (SAM) at: <https://www.sam.gov>
- c) Mechanisms for EFT payment. The Government may make payment by EFT through either the Automated Clearing House (ACH) network, subject to the rules of the National Automated Clearing House Association, or the Fedwire Transfer System. The rules governing Federal payments through the ACH are contained in 31 CFR Part 210.
- d) Suspension of payment. If the Recipient's EFT information in the SAM database is incorrect, the Government is not obligated to make payment to the Recipient under this agreement until the correct EFT information is entered into the SAM database. An invoice or agreement-financing request is not a proper invoice for the purpose of prompt payment under this agreement.
- e) Recipient EFT arrangements. If the Recipient has identified multiple payment receiving points (i.e., more than one remittance address and/or EFT information set) in the SAM database, and the Recipient has not notified the Government of the payment receiving point applicable to this agreement, the Government will make payment to the first payment receiving point (EFT information set or remittance address as applicable) listed in the SAM database.
- f) Liability for uncompleted or erroneous transfers.
  - i) If an uncompleted or erroneous transfer occurs because the Government used the Recipient's EFT information incorrectly, the Government remains responsible for –
    - i) Making a correct payment;
    - ii) Paying any prompt payment penalty due; and
    - iii) Recovering any erroneously directed funds.
  - ii) If an uncompleted or erroneous transfer occurs because the Recipient's EFT information was incorrect, or was revised within 30 days of Government release of the EFT payment transaction instruction to the Federal Reserve System, and –
    - i) If the funds are no longer under the control of the payment office, the

- Government is deemed to have made payment and the Recipient is responsible for recovery of any erroneously directed funds; or
- ii) If the funds remain under the control of the payment office, the Government will not make payment, and the provisions of paragraph d. of this clause apply.
- g) EFT and prompt payment. A payment will have been made in a timely manner in accordance with the prompt payment terms of this agreement if, in the EFT payment transaction instruction released to the Federal Reserve System, the date specified for settlement of the payment is on or before the prompt payment due date, provided the specified payment date is a valid date under the rules of the Federal Reserve System.
  - h) EFT and assignment of claims. If the Recipient assigns the proceeds of this agreement, the Recipient must require, as a condition of any such assignment, that the assignee register in the SAM database and be paid by EFT in accordance with the terms of this clause. In all respects, the requirements of this clause will apply to the assignee as if it were the Recipient. EFT information that shows the ultimate recipient of the transfer to be other than the Recipient, in the absence of a proper assignment of claims acceptable to the Government, is incorrect EFT information within the meaning of paragraph d. of this clause.
  - i) Liability for change of EFT information by financial agent. The Government is not liable for errors resulting from changes to EFT information made by the Recipient's financial agent.
  - j) Payment information. The payment or disbursing office will forward to the Recipient available payment information that is suitable for transmission as of the date of release of the EFT instruction to the Federal Reserve System. The Government may request the Recipient to designate a desired format and method(s) for delivery of payment information from a list of formats and methods the payment office is capable of executing. However, the Government does not guarantee that any particular format or method of delivery is available at any particular payment office and retains the latitude to use the format and delivery method most convenient to the Government. If the Government makes payment by check in accordance with paragraph a. of this clause, the Government will mail the payment information to the remittance address contained in the SAM database.

## 12. Advance Payment

49 CFR § 110.50 authorizes PHMSA to issue advance payments to grant recipients. Recipient must receive prior approval from PHMSA and must meet the required criteria for advance payments be made.

- a) Recipient must possess financial management systems that meet the standards for fund control and accountability as established in 2 CFR 200.302 for awards issued after that date. Recipient must ensure that advance payment requests are limited to the minimum amounts needed and be timed to be in accordance with the actual, immediate cash requirements in carrying out the purpose of the approved program or project.
- b) Recipient must deposit and maintain advance payments in insured accounts whenever possible unless the recipient receives less than \$120,000 in federal awards from all sources or can demonstrate the best reasonably available interest-bearing account would not be expected to earn interest in excess of \$500 per year on Federal cash balances. \$250 for awards issued prior to December 26, 2014.
- c) Recipient submits advance payments based on cash payment needs and not accrued liabilities.
- d) Recipient must remain in compliance with the terms and conditions of their award.
- e) Recipient is not indebted to the United States Government.



- f) Recipient's SAM.gov registration is current and active at the time of the advance payment request.
- g) The recipient maintains supporting documentation in their files and makes them available upon request to PHMSA in order to determine if the costs adhere to the applicable cost principles, statutes and regulations. PHMSA will also monitor to ensure grantee has not requested advance payments beyond immediate disbursing needs and that excess balances were promptly returned to the Treasury.

### 13. Advance Payment Process

To request an advance payment, log into the DOT Electronic Payment System (Delphi E-Invoicing), create and submit a standard invoice, and complete an SF270 form with the Advance Payment Request. This process is similar to requesting a reimbursement. The grant specialist assigned to your account will receive an email generated from the system with the invoice details.

- a) Advance payments must be fully disbursed (example: checks written, signed, and issued to the payees) within 30 days of the date you receive the advance funds from the U.S. Treasury.
- b) Advance payment requests should be submitted no earlier than 10 business days prior to the beginning of the period for which the funds are requested.
- c) PHMSA will check for all of the following criteria:
  - i. Your award balance is sufficient to meet the advance amount requested.
  - ii. Evaluations will be based on cash payments and not on accrued liabilities.
  - iii. You have satisfied program requirements including submission of required federal financial reports for prior quarters/periods.
  - iv. The request is for allowable expenditures.

### 14. Adherence to Original Project Objectives and Budget Estimates

- a) The Recipient is responsible for any commitments or expenditures it incurs in excess of the funds provided by an award. Pre-award costs are those incurred prior to the effective date of the Federal award directly pursuant to the negotiation and in anticipation of the Federal award where such costs are necessary for efficient and timely performance of the scope of work. Such costs are allowable only to the extent that they would have been allowable if incurred after the date of the Federal award, *and only with the written approval of the Program Authorizing Official or delegate.* The Recipient must submit any proposed change, that requires PHMSA's written approval, 30 days prior to the requested effective date of the proposed change. PHMSA will not approve any change to the award during the last 30 days of the award period.

### 15. Prior Approvals

- a) The following expenditures require the PAO's advance written approval:
  - i) Changes in the scope, objective, or key personnel referenced in the Recipient's proposal.
  - ii) Change in the project period. PHMSA must receive this request no later than 30 calendar days prior to the end of the project period. The Recipient must submit a revised budget indicating the planned use of all unexpended funds during the extension period.
- b) The Recipient must submit a revised financial estimate and plan for i) and ii) above.
- c) The PHMSA will notify the Recipient in writing within 30 calendar days after receipt of the request for revision or adjustment whether the request has been approved.

**16. Contracting with Small Businesses, Small Minority-Disadvantaged Businesses, and Small Businesses which are Women-Owned, Veteran-Owned, Disabled Veteran-Owned or located in HubZone Areas**

- a) It is the Department of Transportation (DOT) policy to award a fair share of contracts to small businesses, small minority-disadvantaged business, and small businesses which are women-owned, veteran-owned, disabled veteran-owned or located in a HubZone. DOT is strongly committed to the objectives of this policy and encourages all Recipients of its Grants and Cooperative Agreements to take affirmative steps to ensure such fairness on the awarding of any subcontracts.
- b) The Recipient and any Sub-recipients are encouraged to take all necessary affirmative steps to assure that small businesses, small minority-disadvantaged businesses, and small businesses which are women-owned, veteran-owned, disabled veteran-owned, or located in a HUBZone are used when possible.
- c) Affirmative steps include:
  - i) Placing qualified small businesses, small minority-disadvantaged businesses, and small businesses which are women owned, veteran-owned, disabled veteran-owned, or located in a HUBZone on solicitation lists;
  - ii) Assuring that small businesses, small minority-disadvantaged businesses, and small businesses which are women-owned, veteran-owned, disabled veteran-owned or located in a HUBZone are solicited whenever they are potential sources;
  - iii) Dividing total requirements, when economically feasible, into small tasks or quantities to permit maximum participation by small businesses, small minority-disadvantaged businesses, and small businesses which are women- owned, veteran-owned, disabled veteran-owned, or located in a HUBZone;
  - iv) Establishing delivery schedules, where the requirement permits, which encourage participation by small and minority businesses, and women's business enterprises; and Using the services and assistance of the U.S. Small Business Administration and the Office of the Small and Disadvantaged Business Utilization of the Department of Transportation, as appropriate.

**17. Seat Belt Use Policies and Programs**

In accordance with Executive Order 13043, the Recipient is encouraged to adopt on-the-job seat belt use policies and programs for its employees when operating company-owned, rented, or personally-owned vehicles. The National Highway Traffic Safety Administration (NHTSA) is responsible for providing leadership and guidance in support of this presidential initiative. For information on how to implement such a program or for statistics on the potential benefits and cost-savings to your company or organization, please visit the Buckle Up America section on NHTSA's website at [www.nhtsa.dot.gov](http://www.nhtsa.dot.gov). Additional resources are available from the Network of Employers for Traffic Safety (NETS), a public-private partnership headquartered in Washington, D.C. dedicated to improving the traffic safety practices of employers and employees. NETS is prepared to help with technical assistance, a simple, user-friendly program kit, and an award for achieving the President's goal of 85 percent seat belt use. NETS can be contacted at 1-888-221-0045 or visit its website at [www.trafficsafety.org](http://www.trafficsafety.org).

**18. Ban on Text Messaging While Driving**

a) *Definitions.* The following definitions are intended to be consistent with the definitions in DOT Order 3902.10 and the E.O. For clarification purposes, they may expand upon the definitions in the E.O.

“Driving”-

Attachment B to the Grant Agreement between Wyoming Office of Homeland Security  
and City of Casper  
Page 8 of 15

- i) Means operating a motor vehicle on a roadway, including while temporarily stationary because of traffic, a traffic light, stop sign, or otherwise.
- ii) It does not include being in your vehicle (with or without the motor running) in a location off the roadway where it is safe and legal to remain stationary.

“Text messaging” --- means reading from or entering data into any handheld or other electronic device, including for the purpose of short message service texting, e-mailing, instant messaging, obtaining navigational information, or engaging in any other form of electronic data retrieval or electronic data communication. The term does not include the use of a cell phone or other electronic device for the limited purpose of entering a telephone number to make an outgoing call or answer an incoming call, unless the practice is prohibited by State or local law.

b) In accordance with Executive Order 13513, Federal Leadership on Reducing Text Messaging While Driving, October 1, 2009, and DOT Order 3902.10, Text Messaging While Driving, December 30, 2009, financial assistance recipients and subrecipients of grants and cooperative agreements are encouraged to:

- 1) Adopt and enforce workplace safety policies to decrease crashes caused by distracted drivers including policies to ban text messaging while driving--
  - i) Company-owned or -rented vehicles or Government-owned, leased or rented vehicles; or
  - ii) Privately-owned vehicles when on official Government business or when performing any work for or on behalf of the Government.
- 2) Conduct workplace safety initiatives in a manner commensurate with the size of the business, such as-
  - i) Establishment of new rules and programs or re-evaluation of existing programs to prohibit text messaging while driving; and
  - ii) Education, awareness, and other outreach to employees about the safety risks associated with texting while driving.
- c) *Assistance Awards*. All recipients and subrecipients of financial assistance to include: grants, cooperative agreements, loans and other types of assistance, shall insert the substance of this clause, including this paragraph (c), in all assistance awards.

**19. Rights in Technical Data**

Rights to intangible property under this agreement are governed in accordance with **2 CFR 200.315** - “Intangible Property.”

**20. Notice of News Releases, Public Announcements, and Presentations**

The Recipient must have the PAO’s prior approval for all press releases, formal announcements, or other planned written issuance containing news or information concerning this Agreement before issuance.

**21. Violation of Award Terms**

If the Recipient has materially failed to comply with any term of the award, the PAO may suspend, terminate, or take other remedies as may be legally available and appropriate in the circumstances. If PHMSA determines that a grantee’s application contains material errors, false, fictitious, misleading, or fraudulent statements or claims, PHMSA may choose to not award a grant; or terminate an awarded grant, in whole or in part, consistent with 2 CFR 200.

**22. Reporting Fraud, Waste, or Abuse**

The DOT Inspector General maintains a toll-free hotline for receiving information concerning fraud, waste, or abuse under grants and cooperative agreements. Such reports are kept confidential and callers may decline to give their names if they choose to remain anonymous. The number is: (800) 424-9071.

The mailing address is:  
DOT Inspector General Hotline  
1200 New Jersey Ave SE  
West Bldg 7<sup>th</sup> Floor Washington,  
DC 20590 Email:  
[hotline@oig.dot.gov](mailto:hotline@oig.dot.gov)  
Web: <http://www.oig.dot.gov/Hotline>

**23. Reporting Grantee Executive Compensation/First Tier Sub-Awards (PHMSA Oct, 2010)**

a) **Definitions.** As used in this provision:

“Executive” means an officer or any other employee in a management position.

“First-tier sub-award” means an award issued directly by the prime Awardee to a sub-awardee to provide support for the performance of any portion of the substantive project or program for which the award was received. A sub-award includes an agreement that the prime Awardee or a sub-awardee considers a contract.

“Total compensation” means the cash and noncash dollar value earned by the executive during the Awardee’s preceding fiscal year and includes the following:

- i) Salary and bonus.
- ii) Awards of stock, stock options, and stock appreciation rights.
- iii) Earnings for services under non-equity incentive plans. This does not include group life, health, hospitalization or medical reimbursement plans that do not discriminate in favor of executives, and are available generally to all salaried employees.
- iv) Change in pension value. This is the change in present value of defined benefit and actuarial pension plans.
- v) Above-market earnings on deferred compensation which is not tax-qualified.
- vi) Other compensation, if the aggregate value of all such other compensation (*e.g.*, severance, termination payments, value of life insurance paid on behalf of the employee, perquisites or property) for the executive exceeds \$10,000.

b) **System for Award Management (SAM).** As a recipient of a Federal award you are required to register in the System for Award Management (SAM) at: <https://www.sam.gov>

c) **Notification to Sub-Awardees.** Awardees are required to report information on sub-awards. The law requires all reported information be made public; therefore, the Awardee is responsible for notifying its sub-awardees that the required information will be made public.

d) **Reporting of First-Tier Sub-Awards.** By the end of the month following the month of award of a first-tier sub-award with a value of \$25,000 or more, the Awardee shall report the information below at <http://www.frs.gov> for each first-tier sub-award. (The Awardee shall

follow the instructions at <http://www.fsr.gov> to report the data.) If the Awardee, in the previous tax year, had gross income from all sources under \$300,000, the Awardee is exempt from the requirement to report subcontractor awards. If a sub-awardee, in the previous tax year had gross income from all sources under \$300,000, the Awardee does not need to report awards made to that sub-awardee.

- i) Unique identifier (9-digit Data Universal Numbering System (DUNS) number) for the sub-awardee receiving the award, and for the sub-awardee's parent company, if the sub-awardee has a parent company.
- ii) Name of the sub-awardee.
- iii) Amount of the sub-award.
- iv) Date of the sub-award.
- v) A description of the effort being provided under the sub-award, including the overall purpose and expected outcome or result of the sub-award.
- vi) Sub-award number (assigned by the Awardee).
- vii) Sub-awardee's physical address including street address, city, state, country, 9-digit zip code, and congressional district.
- viii) Sub-awardee's primary performance location including street address, city, state, country, 9-digit zip code, and congressional district.
- ix) The prime award number (assigned by PHMSA)
- x) Awarding agency name. (PHMSA)
- xi) Funding agency name. (PHMSA)
- xii) Government awarding office code. (56)
- xiii) Treasury account symbol (TAS) as reported in Federal Assistance Award Data System.
- xiv) The applicable North American Industry Classification System (NAICS) code.

e) **Reporting Executive Compensation of Awardee.** If the Awardee, in the previous tax year, had gross income from all sources under \$300,000, the Awardee is exempt from the requirement to its executive compensation.

By the end of the month following the month of receipt of a prime award, and annually thereafter, the Awardee shall report the names and total compensation of each of the five most highly compensated executives for the Awardee's preceding completed fiscal year at <https://www.sam.gov> if, in the Awardee's preceding fiscal year, the Awardee received:

- i) 80 percent or more of its annual gross revenues from Federal contracts (and subcontracts), loans, grants (and sub-awards), cooperative agreements, other transaction agreements; and
- ii) \$25,000,000 or more in annual gross revenues from Federal contracts (and subcontracts), loans, grants (and sub-awards), cooperative agreements, other transaction agreements; and
- iii) The public does not have access to information about the compensation of the executives through periodic reports filed under section 13(a) or 15(d) of the Securities Exchange Act of 1934 (15 U.S.C. 78m(a), 78o(d)) or section 6104 of the Internal Revenue Code of 1986. (To determine if the public has access to the compensation information, see the U.S. Security and Exchange Commission total compensation filings at <http://www.sec.gov/answers/excomp.htm>.)

f) **Reporting Executive Compensation of Sub-Awardees.** If the Awardee, in the previous tax

year, had gross income from all sources under \$300,000, the Awardee is exempt from the requirement to report the executive compensation of sub-awardees. If a sub-awardee, in the previous tax year had gross income from all sources under \$300,000, the Awardee does not need to report the executive compensation of that sub-awardee.

By the end of the month following the month of a first-tier sub-award with a value of \$25,000 or more, and annually thereafter, the Awardee shall report the names and total compensation of each of the five most highly compensated executives for each first-tier sub-awardee for the sub-awardee's preceding completed fiscal year at <http://www.frs.gov>, if in the sub-awardee's preceding fiscal year, the sub-awardee received:

- i) 80 percent or more of its annual gross revenues from Federal contracts (and subcontracts), loans, grants (and sub-awards), cooperative agreements, other transaction agreements; and
- ii) \$25,000,000 or more in annual gross revenues from Federal contracts (and subcontracts), loans, grants (and sub-awards), cooperative agreements, other transaction agreements; and
- iii) The public does not have access to information about the compensation of the executives through periodic reports filed under section 13(a) or 15(d) of the Securities Exchange Act of 1934 (15 U.S.C. 78m(a), 78o(d)) or section 6104 of the Internal Revenue Code of 1986. (To determine if the public has access to the compensation information, see the U.S. Security and Exchange Commission total compensation filings at <http://www.sec.gov/answers/excomp.htm>.)

#### **24. 811, Call Before You Dig Program (PHMSA June 2014)**

Damage to pipelines during excavation is a leading cause of accidents resulting in serious injuries and fatalities, but these accidents are preventable, and you can help in preventing them.

811 is designated as the national call-before-you-dig number. Every state has a one-call law requiring excavators to have underground utilities marked before digging.

There are five steps to safer digging:

- 1) Make a free call to 811 a few days before digging.
- 2) Wait the required time – which is prescribed in state law but generally two to three days.
- 3) Locate/mark the utilities accurately. (This step applies to underground facility/utility owners.)
- 4) Respect the marks.
- 5) Dig with care.

The recipient is encouraged to adopt the “811, Call Before You Dig” program for its employees when digging on company-owned, leased, or personally-owned property. For information on how to implement such a program please visit the *811 – Call Before You Dig* section of Pipeline and Hazardous Materials Safety Administration's (PHMSA's) website at [www.phmsa.dot.gov](http://www.phmsa.dot.gov).

#### **25. Access to Electronic and Information Technology (PHMSA DEC 2013)**

Attachment B to the Grant Agreement between Wyoming Office of Homeland Security  
and City of Casper  
Page 12 of 15

Each Electronic and Information Technology (EIT) product or service, furnished under this award, must be in compliance with the Electronic and Information Technology Accessibility Standard (36 CFR 1194), which implements Section 508 of the Rehabilitation Act of 1973, codified at 29 U.S.C. § 794d. The PHMSA Office of Civil Rights will respond to any questions, and will certify Section 508 compliance for the requirement. You can reach the PHMSA Office of Civil Rights at [phmsa.civilrights@dot.gov](mailto:phmsa.civilrights@dot.gov), or 202-366-9638.

**26. Combating Trafficking in Persons (PHMSA JULY 2016)**

PHMSA may terminate grants, cooperative agreements, or take any of the other remedial actions authorized under 22 U.S.C. 7104(g), without penalty, if the grantee or any subgrantee, engages in, or uses labor recruiters, brokers, or other agents who engage in-

- a) severe forms of trafficking in persons;
- b) the procurement of a commercial sex act during the period of time that the grant, or cooperative agreement is in effect;
- c) the use of forced labor in the performance of the grant or cooperative agreement; or
- d) acts that directly support or advance trafficking in persons, including the following acts:
  - i) Destroying, concealing, removing, confiscating, or otherwise denying an employee access to that employee's identity or immigration documents.
  - ii) Failing to provide return transportation or pay for return transportation costs to an employee from a country outside the United States to the country from which the employee was recruited upon the end of employment if requested by the employee, unless-
    - 1) exempted from the requirement to provide or pay for such return transportation by the Federal department or agency providing or entering into the grant, or cooperative agreement; or
    - 2) the employee is a victim of human trafficking seeking victim services or legal redress in the country of employment or a witness in a human trafficking enforcement action.
  - iii) Soliciting a person for the purpose of employment, or offering employment, by means of materially false or fraudulent pretenses, representations, or promises regarding that employment.
  - iv) Charging recruited employees unreasonable placement or recruitment fees, such as fees equal to or greater than the employee's monthly salary, or recruitment fees that violate the laws of the country from which an employee is recruited.
  - v) Providing or arranging housing that fails to meet the host country housing and safety standards.

**27. Prohibition on Awarding to Entities that Require Certain Internal Confidentiality Agreements (PHMSA FEB 2015)**

- a) The Recipient shall not require employees or subcontractors seeking to report fraud, waste, or abuse to sign or comply with internal confidentiality agreements or statements prohibiting or otherwise restricting such employees or subcontractors from lawfully reporting such waste, fraud or abuse to a designated investigative or law enforcement representative of a federal department or agency authorized to receive

such information.

- b) The Recipient shall notify employees that the prohibitions and restrictions of any internal confidentiality agreements covered herein are no longer in effect.
- c) The prohibition in paragraph (a) above does not contravene requirements applicable to Standard Form 312, Form 4414, or any other form issued by a Federal department or agency governing the nondisclosure of classified information.
- d) In accordance with section 743 of Division E, Title VII, of the Consolidated and Further Continuing Resolution Appropriations Act, 2015 (P.L. 113-235), use of funds appropriated (or otherwise made available) under that or any other Act may be prohibited, if the Government determines that the Recipient is not in compliance with the provisions herein.  
The Government may seek any available remedies in the event the Recipient fails to comply with the provisions herein.

## **28. Copyrights**

PHMSA reserves a royalty-free, nonexclusive, and irrevocable license to reproduce, publish or otherwise use, and to authorize others to use, for Federal government purposes:

- a) The copyright in any work developed under a grant, sub award, or contract under a grant or sub award; and
- b) Any rights of copyright to which a Recipient, sub recipient or a contractor purchases ownership with grant support.

## **29. Reporting**

- a) *Biannual Federal Financial Report (FFR) (SF-425)* – The mid-year FFR provides an update on the status of funds for the first half of the performance period. This report is cumulative. The biannual FFR is due no later than 11:59pm Eastern Standard Time (EST), April 30<sup>th</sup> and December 30<sup>th</sup> of the performance year.
- b) *Biannual Performance Report* – The biannual performance report (form OMB Control Number: 2137-0586) provides the status of the activities performed during the first half of the performance period. The biannual performance report is due no later than 11:59pm Eastern Standard Time (EST), April 30<sup>th</sup> and December 30<sup>th</sup> of the performance year.
- c) *End of year financial report* – The end of year FFR closes-out the financial reporting for the performance period. An end of year FFR is due no later than 11:59pm Eastern Standard Time (EST), 90 days after the end of the performance



period.

- d) *End of year performance report* – The final performance report (form OMB Control Number: 2137-0586) provides the status of the activities performed during the entire performance period. The end of year performance report is due no is due no later than 11:59pm Eastern Standard Time (EST), 90 days after the end of the performance period.

A request for extension of the due date for a mid and end of year reports must be made in writing to PHMSA no later than 15 days before the reports are due. The request must include the reason for the request and the requested due date.

(End of provision)

RESOLUTION NO. 23-92

A RESOLUTION AUTHORIZING THE GRANT AWARD AGREEMENT BETWEEN THE WYOMING OFFICE OF HOMELAND SECURITY AND CITY OF CASPER.

WHEREAS, the City of Casper was awarded a grant from the Wyoming Office of Homeland Security in the amount of Sixty-Three Thousand Eighty-Two Dollars (\$63,082) with a local match of Fifteen Thousand Seven Hundred Seventy Dollars and Fifty Cents (\$15,770.50) in in-kind services; and,

WHEREAS, the parties desire to enter into the Grant Award Agreement. The grant funds will be used to purchase a hazardous material confined space shipping container training prop. The in-kind services will be provided by the City of Casper to install the training prop at the regional training facility.

NOW, THEREFORE, BE IT RESOLVED BY THE GOVERNING BODY OF THE CITY OF CASPER, WYOMING: That the Mayor is hereby authorized and directed to execute, and the City Clerk to attest this Resolution and the above described Agreement.

PASSED, APPROVED, AND ADOPTED on this \_\_\_\_ day of \_\_\_\_\_, 2023.

APPROVED AS TO FORM:



ATTEST:

\_\_\_\_\_  
Fleur Tremel  
City Clerk

CITY OF CASPER, WYOMING  
A Municipal Corporation

\_\_\_\_\_  
Bruce Knell  
Mayor

April 19, 2023

MEMO TO: J. Carter Napier, City Manager *JCN*

FROM: Andrew Beamer, P.E., Public Services Director *AB*  
Alex Sveda, P.E., City Engineer *AS*  
Cindie Langston, Solid Waste Division Manager  
Steven Stolte, E.I.T., Associate Engineer I

SUBJECT: Reject Bids for the 2023 5-Year Solid Waste Baler Bag Procurement,  
Project No. 23-006.

Meeting Type & Date  
Regular Council Meeting  
May 2, 2023

Action Type  
Minute Action.

Recommendation  
That Council, by minute action, reject all bids received for the 2023 5-Year Solid Waste Baler Bag Procurement, Project No. 23-006.

Summary  
On April 6, 2023, one (1) bid was received for the 2023 5-Year Solid Waste Baler Bag Procurement Project. The bid was as follows:

| <u>CONTRACTOR</u>   | <u>LOCATION</u> | <u>BASE BID</u> |
|---------------------|-----------------|-----------------|
| Globex Partners LLC | Brightwater, NY | \$1,724,300.00  |

An incomplete bid was submitted by Globex Partners LLC where no bid bond was received.

City staff recommends to reject this bid and re-bid in the near future.

Financial Considerations  
Funding for the project is from the operating supplies account of the Balefill Fund.

Oversight/Project Responsibility  
Steven Stolte, E.I.T., Associate Engineer I

Attachments  
None

April 18, 2023

MEMO TO: J. Carter Napier, City Manager *SN*  
FROM: Ethan Yonker, Risk Manager  
Tracey L. Belser, Support Services Director *LB*  
SUBJECT: Casper's Council of People with Disabilities New Member Appointment

**Meeting Type & Date**

Council Meeting  
May 2, 2023

**Action type**

Minute Action

**Recommendation**

That Council, by Minute Action, appoint one (1) new member to Casper's Council of People with Disabilities for a term of three (3) years beginning May 2, 2023.

**Summary**

Casper's Council of People with Disabilities (CCPD) bylaws require that the City Council advisory group maintain between twelve and sixteen active members. A member of the Council has stepped down and asked to be removed from the membership list. To fill this voting member vacancy, the CCPD reviewed applications that were provided during the last membership drive. The CCPD Chairperson recommends the appointment of the following individual by City Council. The recommended appointee is:

1. Tekka Perry

**Financial Considerations**

None

**Oversight/Project Responsibility**

CCPD Chair and City of Casper CCPD Representative(s)

**Attachments**

CCPD Officer and Membership List

## CCPD Officer and Membership List

5/2/2023

| <u>Name</u>         | <u>Role</u> | <u>Committe</u> |
|---------------------|-------------|-----------------|
| Ardell Breed        | Member      | QOL             |
| Austin Berlin       | Chairperson | QOL, PR         |
| Bonnie Wilson       | Vice-Chair  | EVNT            |
| Copper Mack         | Member      | FR              |
| Teka Perry          | Member      |                 |
| Ethan Yonker        | Treasurer   | QOL             |
| John Wall           | Member      | QOL, PR         |
| Linda Jones         | Member      | FR              |
| Maria "Masha" Flinn | Secretary   | QOL, PR         |
| Marty Wood          | Member      |                 |
| Maureen Barnes      | Member      | QOL, EVNT, FR   |
| Stephanie Singer    | Member      | EVNT            |
| Scotia Sutherland   | Member      | EVNT            |
| Jenny Miller        | Member      |                 |
| Dawn Lacko          | Member      | EVNT            |
| Charles Fritz       | Member      | QOL, FR         |

### CCPD Liasion & Alternates

|                      |                 |
|----------------------|-----------------|
| Ray Pacheco          | Council Liaison |
| Ann Alacron          | Council Liaison |
| Nicole "Nikki" Green | Council Liaison |
| Liz Becher           | Council Liaison |
| Zulima Lopez         | Council Liaison |
| Scott Dresher        | Council Liaison |